

BIKES 2020

CONTENTS/

HIGHLIGHTS



04

AERO
DEVELOPMENT

06

LITENING
C:68X SLT

08

AERIUM
C:68 TT

10

NUROAD
SL

12

ELITE
C:68X SLT

14

STEREO
170 TM

16

STEREO
120 HPC SLT

18

SL FAMILY
KIDS BIKES

20

STEREO
120 YOUTH

22

KATHMANDU
PRO

24

CROSS
PRO

26

TEAM WS

HIGHLIGHTS

4

HARDTAIL

30

FULLSUSPENSION

88

ROAD RACE

140

TRIATHLON

212

WOMEN'S SERIES

230

TOUR

284

URBAN

338

KIDS

358

GEOMETRY

420



FOR US —

We love bikes. It's as simple as that! From the first turn of the pedals on the morning commute to a fun after-work loop or battling it out with our rivals in a sweat fest. That's why we build bikes that live up to our expectations 100%, that get our hearts beating in watts, and that we ourselves love to ride. Every single bike in our range is the culmination of our passion and know-how. And that's something that benefits everyone – you and us. New ideas make the world go round, which is why we never stop working on ourselves and on creating the perfect bike. For you, for everyone else, and for us. Because we want the best for everyone.



IN WATTS WE TRUST

MORE THAN 100 HOURS
OF TESTING IN THE WIND TUNNEL

Aerodynamic road bikes have been a big part of CUBE's portfolio for over 20 years. Our flagship product, the Aerium series, has always represented the state of the art in aerodynamics and has proven its mettle again and again in thousands of races the world over. But we don't rest on our laurels. By continuously working to evolve our materials technologies, we have entered a new dimension in integration and aerodynamic gains. In 2016, this led us to design an uncompromising triathlon bike – free from the shackles of the UCI rule book and with the clear goal of building the world's fastest triathlon bike.

The success of our Aerium C:68 prompted us to translate these brand-new technologies and our experience in aerodynamics onto the field of road racing. We completely resculpted every last piece of tubing on the Aerium C:68 to make it fully UCI compliant and ran hundreds of simulations until we were completely happy with the performance. The result is the Aerium C:68 TT. It combines the sleek aerodynamic refinement and integration of our triathlon bike with the safety and braking performance only hydraulic disc brakes can guarantee.



Aerodynamics like you've never seen before!

When it came to designing the Litening C:68X, our engineering team were determined to make it the fastest bike in the Tour de France peloton. They sweated every last technical detail – from the cable routing to the tube profiles to the external mounted parts – to reduce frontal area and make it ultra-slippery through the air. Not only does the brand-new Litening C:68X set a new benchmark in the wind tunnel, but it also delivers a supremely comfortable ride wrapped up in a super-stiff frame and all at a weight virtually unparalleled amongst aero bikes. We managed to save around 30 watts of drag compared with the predecessor model. Together, the aerodynamic frame and fork along with the seamlessly integrated cockpit and super-aero seat post deliver a zero-compromise bike that lives up to our expectations and is a genuine game-changer.

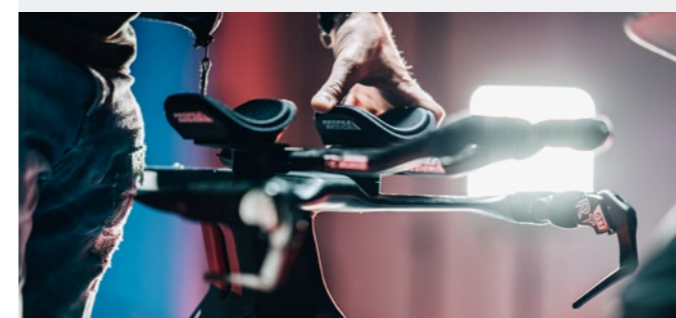
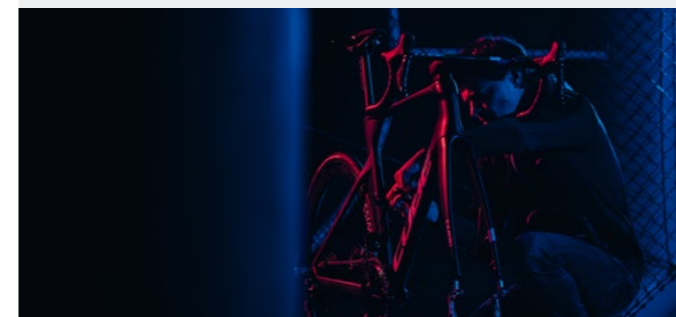

+ LITENING C:68X SLT

An outstanding aero bike is more than just aerodynamic tubing profiles. That's why our engineers paid special attention to every last detail. Internal cable routing from front to back along with fully integrated shifting electronics, seat clamp and computer mount not only keep the bike looking ultra clean but also keep the frontal area down to the absolute minimum for best-ever aerodynamics.



TECHNOLOGY



30 WATT POWER SAVING

155 CARBON FIBRE LAYERS

>30% POWER SAVING

1000 OVER 1,000 CALCULATIONS AND FLOW SIMULATIONS

100 H OF TESTING IN THE WIND TUNNEL

<980 G FRAME WEIGHT

+ **AERIUM C:68 TT**



TECHNOLOGY



WIND-CHEATING, UCI-COMPLIANT AND FULL CARBON – SPEED, PERFECTED

There are two ways to build a really aerodynamic frame. The first involves ignoring all the rules, and just seeing where the science leads you. The result of that approach is our Aerium – still, in our testing, the world’s fastest triathlon frame. But if you want to race under the auspices of the UCI, a different approach is needed. Building on our Aerium’s successes, we wanted to build an aerodynamic machine that could be raced at the highest level. So we broke out the UCI rulebook, had a careful think, did a whole lot of very advanced Computer Fluid Dynamics modelling, and put the resulting designs in the wind tunnel for extensive testing. Over and over again. The result is the frame you see here – fully UCI compliant, as aerodynamically smooth as it’s possible to make a time trial frame, incredibly light and unbelievably efficient.

+ **NUROAD SL**



TECHNOLOGY

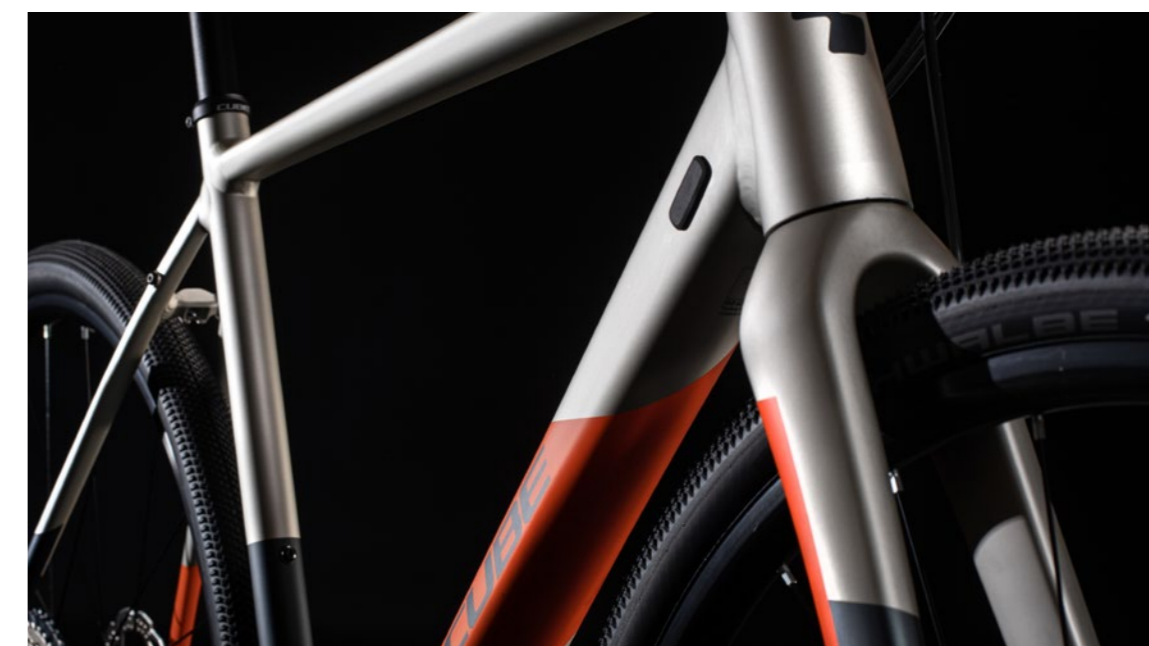

SHIMANO GRX 1X11 GEARS AND MAVIC ALLROAD DISC WHEELS: AN ALPINE GRAVEL PASS-STORMER

In the early days of Alpine road racing the roads were often little more than dirt tracks – which means that the Tour de France riders of nearly a century ago would probably have given up a limb for one of our Nuroad SLs. With the pace and comfort of our Attain road race series and the handling and ruggedness of one of our Cross Race bikes, its DNA is pure racing tradition. Featuring Shimano’s new 1x11 GRX transmission with a wide-ranging 11-42 tooth cassette, our product engineers have selected a range of components that are designed for one purpose: to boost your speed. The frame features all the benefits of our Nuroad series, including neat internal cable routing and a geometry that makes handling the variable grip of unsurfaced roads easier. We even fitted a full carbon fork, which saves weight and adds to ride comfort.

+ ELITE C:68X SLT

When we set out to develop the C:68 technology, one of our biggest priorities was to reduce the amount of resin to what we consider the ideal level: 32%. We also enhanced the resin's texture by adding special nanoparticles to make it even tougher than ever. C:68X builds on this know-how and takes it to the next level by incorporating specific fibre choices and orientations. With this new technology, we can select and orient the carbon fibres to add stiffness or compliance to precise sections of the frame as needed. Fibres on each part of the frame are oriented according to load, which allows us to exploit the full potential of carbon fibre and deliver huge improvements in ride performance. Say goodbye to the homogeneous weave of the C:68 frame and hello to C:68X technology in all its glory: always the perfect materials and orientations needed for the specific frame section. We use up to six different fibre types in layup and actually save weight despite the increased aerodynamic efficiency and full system integration. The result: Even more rigidity with compliance exactly where it's needed for a more comfortable and safer frame. Sound like a pipe dream? Welcome to the future!



TECHNOLOGY

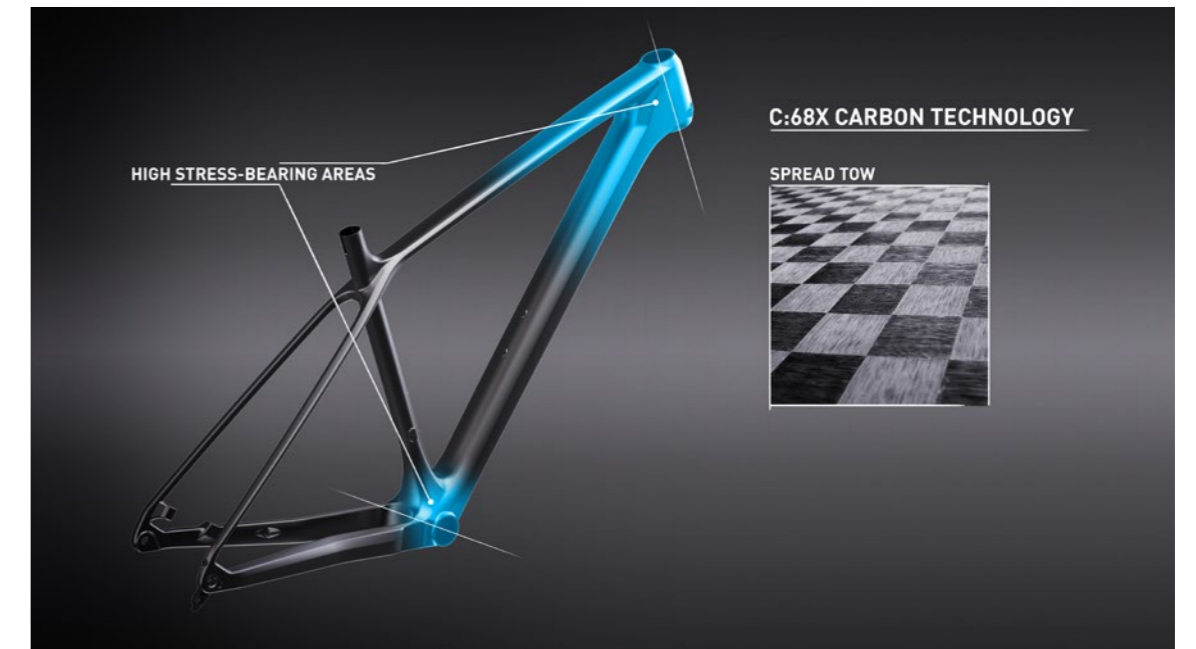

SRAM EAGLE AXS™ COMPONENTS, FOX FLOAT FACTORY SUSPENSION AND PREMIUM CARBON - CROSS-COUNTRY PERFECTION

15% LIGHTER

25% MORE COMFORT

7% STIFFER



+ STEREO 170 TM



TECHNOLOGY

ROCKSHOX ULTIMATE SUSPENSION MEETS 29ER WHEELS AND 170MM TRAVEL FOR MOUNTAIN-TAMING AWESOMENESS

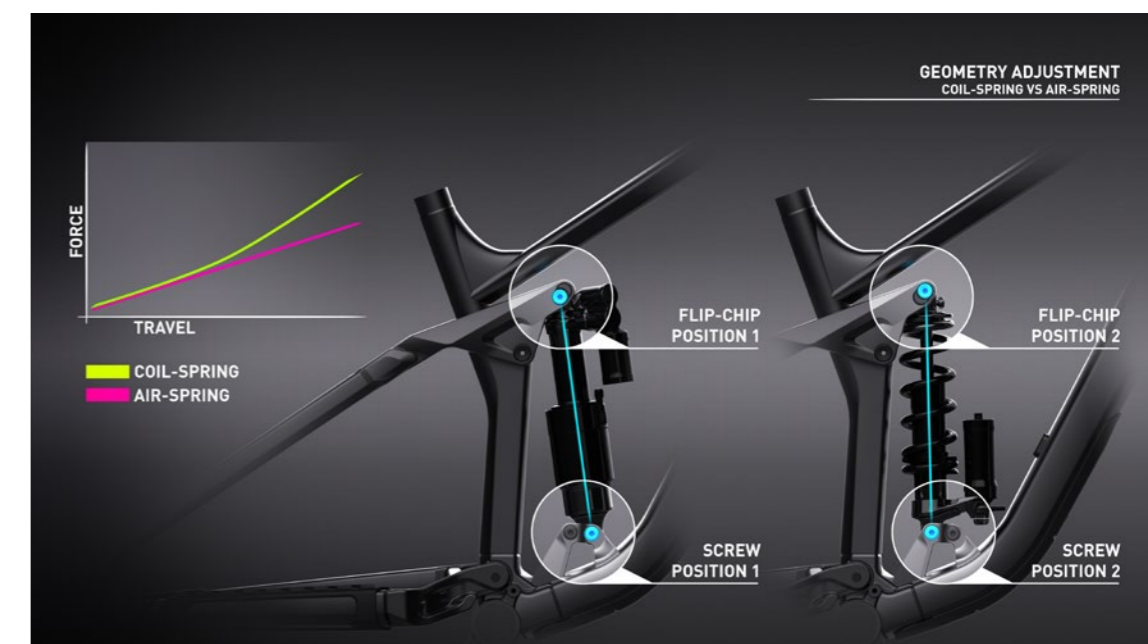

FLIP CHIP

In order to get the most out of your air and coil shocks, the frame kinematics must meet various requirements. The brand-new CUBE Stereo 170 series incorporates the clever flip chip 2-in-1 solution for the perfect amount of progression on any shock type.

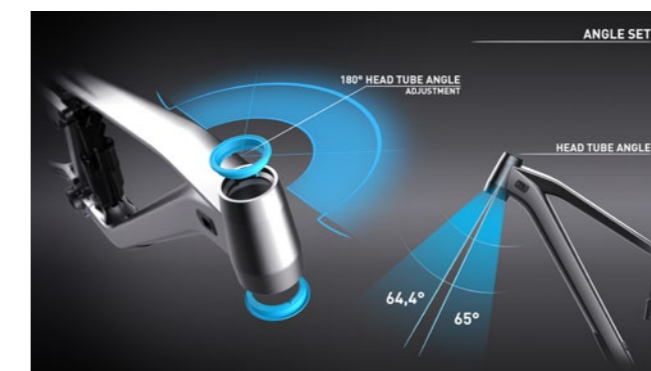

ANGLE SET

The reversible headset inserts from ACROS are as simple as they are efficient! Make your head tube angle steeper or slacker by 0.6° to dial in your descents or achieve the ideal bottom bracket height in combination with a 180mm fork.

+ STEREO 120 HPC SLT

In many ways the Stereo 120 is the full suspension bike that kick-started our reputation for building comfortable, high performance trail bikes. New for 2020, we've added a carbon main triangle for even lower weight – so you can enjoy your trail time more. Years of experience in carbon frame construction means that our engineers know exactly where to add material for strength, and where they can remove it to save weight – all backed by the reassurance of our extensive in-house testing. The rest of the frame is pure Stereo 120 goodness, featuring the short rocker, covered pivot bearings and efficient kinematics of its predecessors for superb traction, comfort and control. The tapered headtube and Boost rear axle ensure great handling and steering precision, and big 29er wheels roll easily. Ride where your curiosity takes you...



TECHNOLOGY

SHIMANO XT PRECISION WITH FOX FACTORY SMOOTHNESS: TRAVEL LIGHT, TRAVEL FAST.

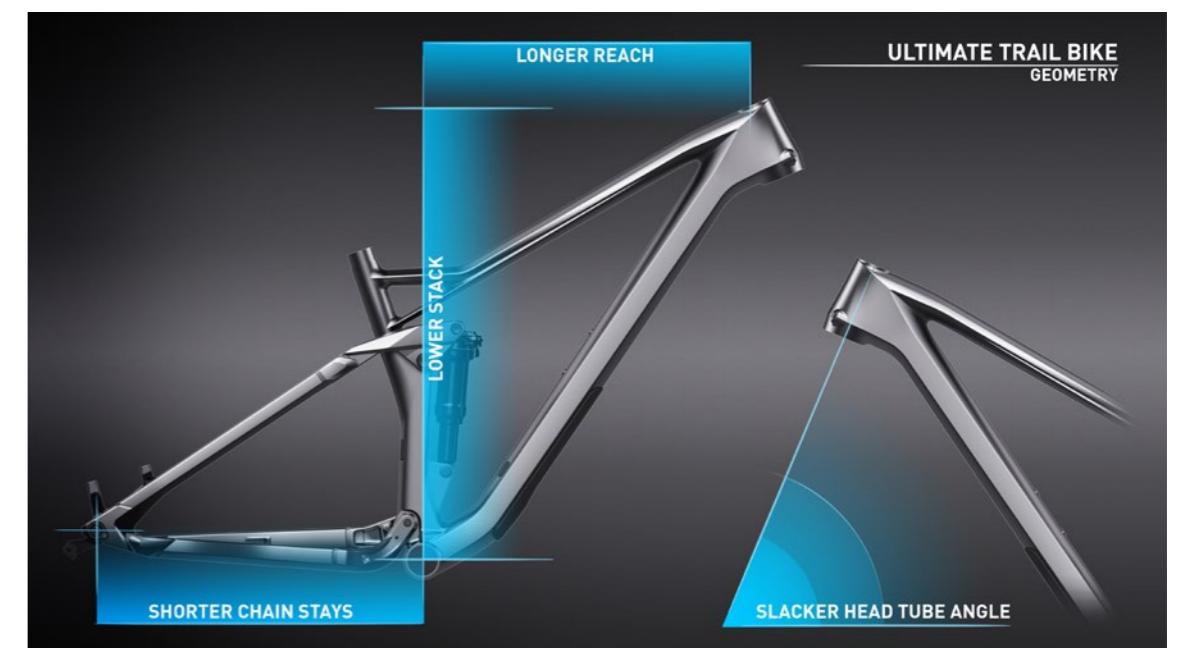

+ **SL FAMILY
KIDS BIKES**



CUBIE 180 SL



ACID 200 SL



ACID 240 SL

TECHNOLOGY

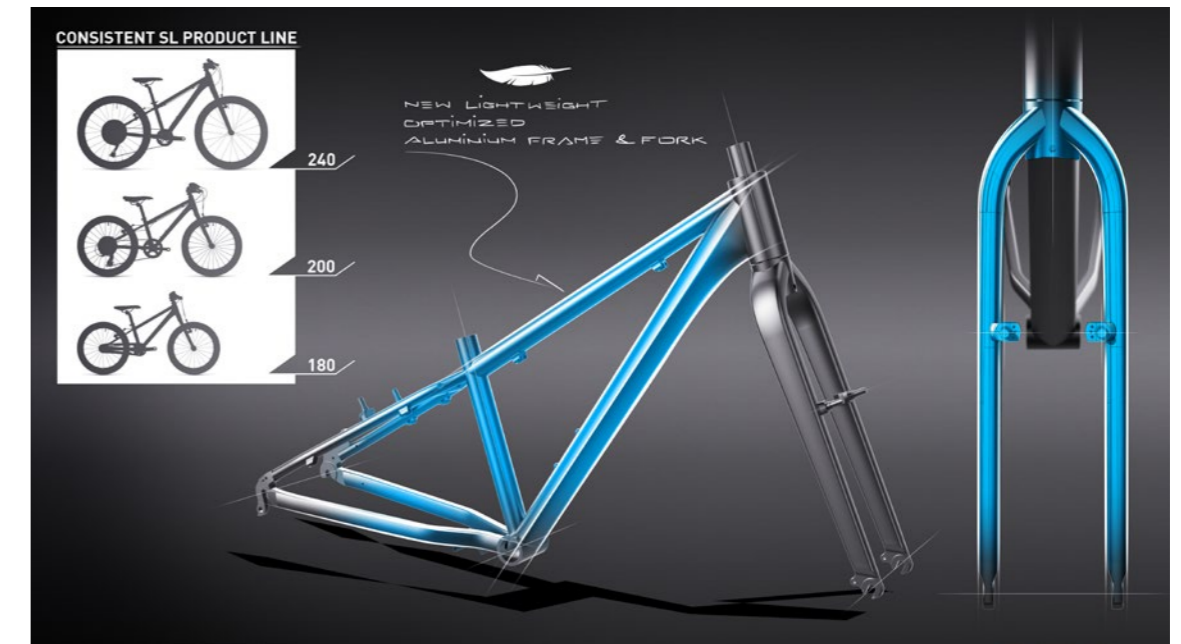

MAKE LIGHT WORK OF RIDING!

Less weight = more fun, and for kids, that's the best reason to ride! This was our biggest goal when designing the SL kids series. We use light aluminium forks developed in-house to bring down the weight of the front end significantly. A light wheelset makes acceleration child's play – super-light tyres and rims reduce the rotating mass and help youngsters effortlessly keep up with the grown-ups. All components have been chosen to ensure the bikes live up to their SL – super light – name and are as robust and child-friendly as those fitted to our "normal" kids bikes. Biking just got a whole lot more fun!

+ STEREO 120 YOUTH ACTION TEAM



TECHNOLOGY



A JUNIOR FULL SUSPENSION BIKE WITH REAL MOUNTAIN BIKE COMPONENTS

YOUNG FULL-SUSSER RELOADED!

Nothing beats the sound of children's laughter – and our Stereo 120 Youth will put a huge smile on the faces of young bikers even on challenging trails. A "genuine" Stereo, simply scaled down for maximum control in smaller hands. The Sram Eagle 12-speed transmission offers the perfect range of gears for growing legs to tackle any trail, while the powerful hydraulic disc brakes deliver maximum control on the descents. A Suntour fork and air shock can be set up with absolute precision to suit even the lightest of riders. Jump on the bike and into your next adventure – with the biggest grin on your face!

+ KATHMANDU PRO

You can't broaden the mind if you're not comfortable. That's why the Kathmandu is built with our renowned Efficient Comfort Geometry, which puts you in the optimum position for the best blend of comfort and performance - mile after mile after mile. Lightweight double butted tubing saves weight where possible and maintains stiffness and strength where needed, so the Kathmandu Pro remains stable and predictable on any road, and carrying any load. Speaking of which, our engineers are particularly proud of the IC 2.0 luggage carrier, which combines sleek looks with exceptional strength, rigidity and ease of use. And neat touches like cables routed inside the downtube and a kickstand mounted directly to the rear dropout mean you can be assured we've thought of everything.



TECHNOLOGY

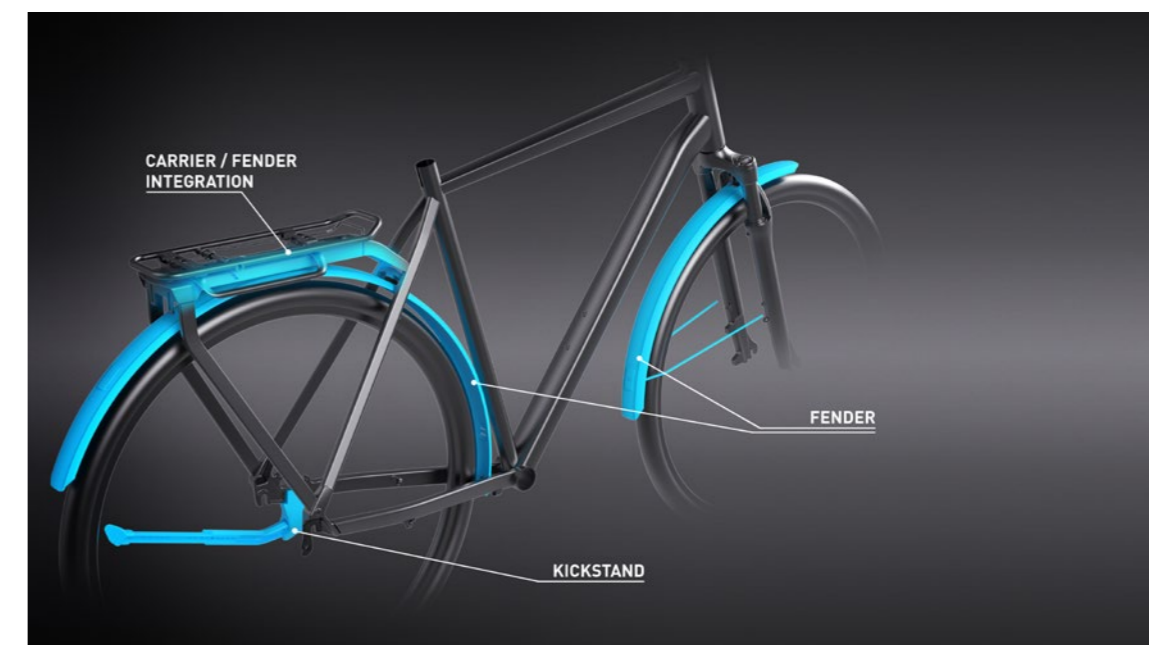

+ CROSS PRO

Cross by name, adaptable by nature. Light, nimble and equipped to be reliable and versatile, the Cross is your fast and comfortable companion for everything from urban rat-runs to rural adventures. With Smooth Welding and ultra-neat rack and mudguard mounts, it's also a real looker.



TECHNOLOGY



ROCKSHOX AIR SUSPENSION AND SOPHISTICATED FRAME DESIGN: GO ANYWHERE

The whole point of a bike, as far as we're concerned, is to inspire adventure. The Cross Pro's rugged design and versatile equipment means that you won't have to turn around in a dead-end street if the way ahead is a dirt road - and isn't that exactly the kind of thing that adventure is all about? Borrowing features inspired by our mountain bike frames, the Cross Pro's light chassis boasts double butted tubes for lighter weight, a tapered head tube for precise steering and internally routed gear cables for long-lasting, smooth gear shifts. It's also RILink carrier compatible, with mounting points hidden out of the way inside the rear dropouts - a superb system that allows for full mudguards and a luggage carrier to be fitted neatly and unobtrusively. It's the Swiss Army Knife of bikes - ready to take on anything, wherever you find yourself.

FOR US #WOMEN

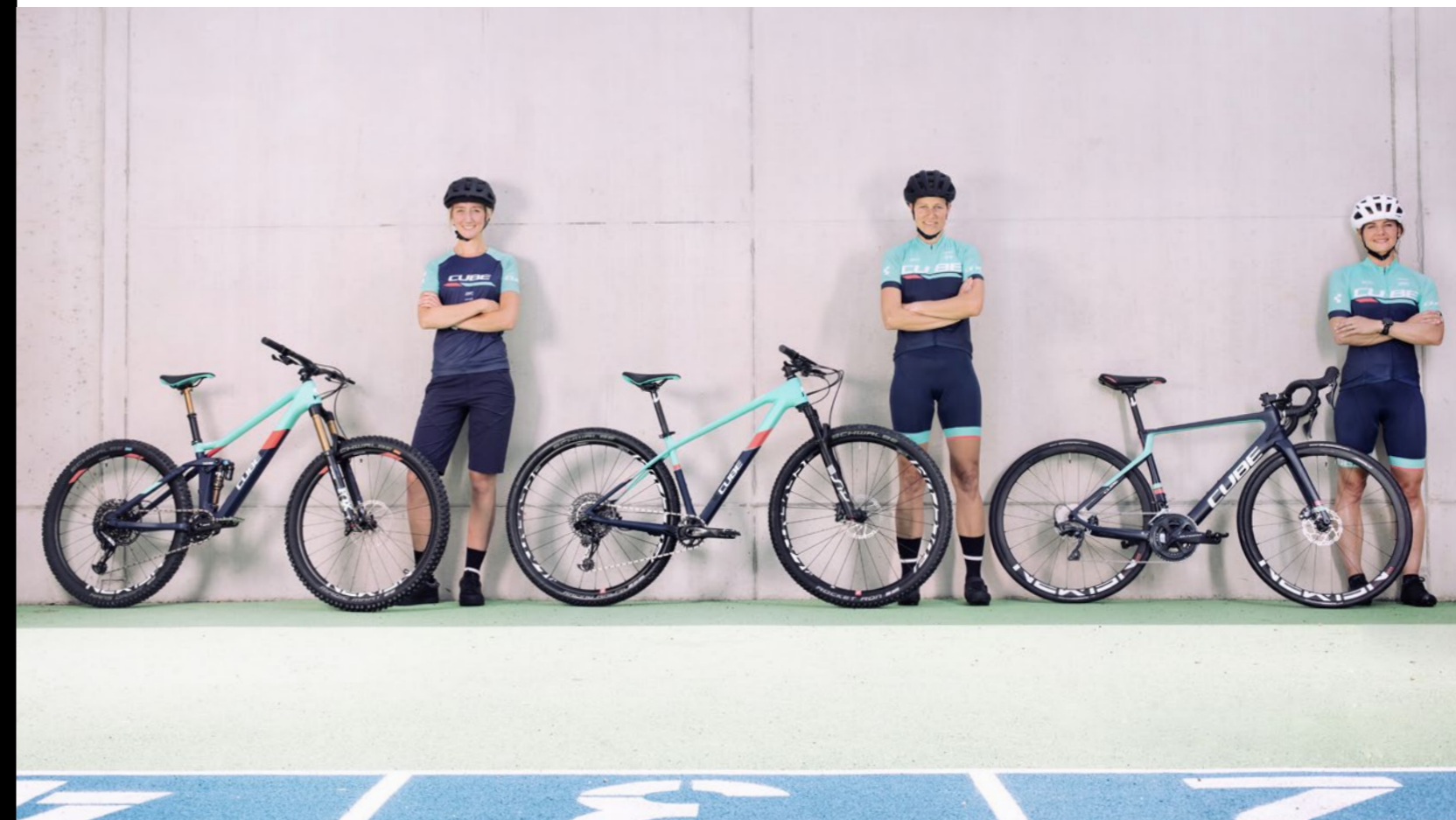

WOMEN
TEAMLINE

Whether it's your bike or your clothes – things should just fit, full stop. That's why our Women Teamline range has a broad range of products developed specially for women cyclists. From the perfect outfit to the bike to match, everything is designed specifically to meet the needs of women bikers. Whatever you decide to do, these bikes are built to deliver what they promise – from surfing the local trails or tackling multi-day trans-Alpine crossings to touring with your significant other or going full-gas on the mountain stages.

Carefully selected components and women-specific features make every bike an unbeatable all-round package. The Teamline WS is the perfect addition and has been subject to rigorous testing for fit, functionality and comfort by our pro athletes and amateur bikers. Whoever you are and wherever you're going – we've got you covered.



T-SHAPE
MORE LEGROOM
when pedalling thanks to the svelte design of the saddle tip.

SHORT-NOSE
GREATER EFFICIENCY
courtesy of the overall length and pronounced T-shape which together allow the saddle to be positioned further forward.

Angle – 1.5 degrees

recommended range

FLEX AREA
MAXIMUM PRESSURE RELIEF
for sensitive areas thanks to flex in the saddle shell.

EXTRA ROOM
to make stepping on and off easier.

WOMEN
specific characteristics

TARGETED PRESSURE RELIEF
thanks to an anatomical channel designed around the female form for more precise pressure relief.

SPECIFIC ADAPTABILITY
Women-specific saddles feature slightly higher foam padding for better adaptability to the female muscle anatomy.

IMPROVED CONTACT AREA
Built slightly wider for a contact area better suited to the anatomical differences in the female pelvis.

SADDLE PORTFOLIO

	APPLICATION	EFFECT
TREKKING	<p>SHEN SERIES</p> <p>COMFORT TOUR TREKKING</p> <p><i>Sitz dich Fit</i></p>	<p>The unique Shen series applies the PONS0 ergonomic sitting principle to deliver comfort like never before thanks to a combination of individually shaped foam layers with different properties and a specially contoured saddle shell. Ergonomic channels minimise discomfort around the sit bones and sensitive nerve pathways. These design features work in harmony to distribute load to the muscles instead and also help to reduce friction. The SHEN series is No. 1 in our new comfort standard.</p>
MOUNTAINBIKE	<p>SEQUENCE</p> <p>TOUR TREKKING HYBRID</p>	<p>The comfort-oriented SEQUENCE series zeroes in on optimal pressure distribution by deploying large memory foam inserts – ideal for long tours in a slightly bent-forward position. The memory foam inserts extend to the flanks and work with the underlying design to not only deliver noticeably more legroom but also reduce friction on the thighs. The compact design makes getting on and off the bike a cinch. The ideal all-round saddle for comfortable sport-oriented touring.</p>
ROAD	<p>SEQUENCE+</p> <p>TREKKING HYBRID ALLMOUNTAIN</p>	<p>The outstanding comfort of the SEQUENCE series has been taken to the next level with the unique design of the SEQUENCE PLUS models created specially for ambitious riders who don't want to compromise on comfort. The advanced saddle shell design allows the addition of extra foam height despite the streamlined silhouette. Additional legroom comes courtesy of the pronounced T-shape and downward-sloping outer edges. Position the saddle forward for maximum efficiency thanks to the extensive adjustment range – for comfort and performance without compromise.</p>
ROAD	<p>VENEC SERIES</p> <p>ALLMOUNTAIN MTB</p>	<p>Not only do the VENEC saddles come with a super-compliant shell, they also effectively conduct ground vibrations through the rails and away from the rider to make this series a flexible all-rounder for most kinds of bikes and uses. The pronounced anatomical channel with its special design promotes a variety of riding positions for maximum variability. The result? The streamline VENEC series is ideal for use in rougher terrain and where flexibility is king.</p>
ROAD	<p>NUANCE SERIES</p> <p>MTB CROSS COUNTRY ROAD</p>	<p>Light weight meets effortless design for pure cycling enjoyment. Designed for an extremely bent-forward and aggressive riding position, the NUANCE SL and SLT series deliver maximum pressure relief for the perineum thanks to cutouts in the underneath of the shell. These saddles are designed specifically to enable fast, powerful pedalling. Similar to other saddles in our range, the overall length and contours promote a more centrally aligned riding position for greater efficiency. The low weight is testimony to the competitive focus of this series.</p>

HARD TAIL



HARDTAIL



TOUR
TOUR

SPORT
SPORT

ENDURANCE
ENDURANCE

RACE
RACE

DIRT JUMP
DIRT JUMP

034 **ELITE** C:68X | 29

042 **REACTION** C:62 | 29

054 **REACTION** HPA | 27.5, 29

064 **CMPT** | 27.5, 29

084 **FLYING CIRCUS** | 26

086 **NUTRAIL** | 26

ELITE

There's nothing quite like a lightweight hardtail for marathon racing. And there's no marathon race hardtail quite like the brand new CUBE Elite. Combining inspirational low weight with efficient rigidity and surprising comfort and resilience, it's the standard by which all other marathon race hardtails are judged.

REACTION

Fast, light, strong: you really can have it all. The Reaction's finely tuned frame combines the low weight, efficiency and responses of a cross-country race bike with the versatility of a trail bike, including Boost rear end and for most of them an easy stealth dropper post upgrade. Bring it on.

CMPT

A hardtail is the can-do bike of mountain biking – and our CMPT hardtails can do more than most. Crafted from aluminium and designed to offer the optimum balance of weight, strength and great handling, whichever one you pick is sure to win you over. Trail riding was never more accessible.

FLYING CIRCUS

The Flying Circus is the rebirth of a Cube legend – our dirt jump and pump track bike is back. With perfectly balanced geometry for aerial antics, it's not just a tough cookie but a good-looking one, too – designed with strength in mind but with an eye on aesthetics, too.

NUTRAIL

Fads come and go, but a Nutrail is for life. Until you've experienced the go-anywhere, ride-everything potential of our chunky-tired hardtail bruiser, you won't know what you're missing. Gravel, sand, mud, snow or scree – ain't no obstacle tricky enough to keep your Nutrail from rolling.

FOR us #Racers

If there's one thing our engineers have learnt over the years, it's that you can always squeeze a bit more performance out of a frame. That's why they went back to the drawing board with the Elite. It was already stiff, light, comfortable and agile – but the new one is 15% lighter, designed with even greater comfort in mind, and features revised Agile Ride Geometry designed with marathon riding and endurance cross-country in mind. It's all possible thanks to the combination of our high-end C:68X carbon and Advanced Twin Mold manufacturing technology, which gives our engineers the ability to add or remove precise quantities of carbon to create the perfect blend of characteristics. Slender seat stays help absorb trail vibration for greater comfort over long distances, while the tapered head tube and Boost axle at the rear help maintain precise steering and incredible pedalling efficiency. There's even provision to upgrade to an internally routed dropper post. Better than before? Definitely. The best out there? Well, we think so. But we'll let you be the judge...



ELITE C:68X SLT

317300 carbon'n'blue



There is absolutely nothing in the world that our engineers and product managers like more than being told to build the ultimate bike, no expense spared. In the case of the brand-new Elite C:68X SLT, they really went to town. Kicking off with Sram's XX1 Eagle AXS wireless electronic transmission, they picked only the best of the best for our range-topping marathon hardtail. With crisp, clean shifts, no cables and an incredible range of ratios, Sram's wireless groupset was the obvious choice. Matching Sram Level Ultimate hydraulic disc brakes offer equivalent stopping power, while Newmen Advanced carbon wheels and Newmen carbon cockpit components round off the equipment package – and Fox's Float Factory fork offers 100mm of smooth travel and superb steering precision. But the kit is only half the story, of course. Our engineers also built a brand-new frame for the Elite C:68X SLT, 15% lighter than before and with revised Agile Ride Geometry for a more comfortable ride on long rides and extended cross-country races. Crafted from next-generation C:68X carbon, it's both impressively efficient and surprisingly comfortable, thanks to design features like the tapered head tube and narrow seat stays. With provision for an upgrade to a stealth dropper post, it's the ideal base for our no-compromise marathon machine. Are you ready to race? Because the Elite C:68X SLT definitely is.

FRAME# C:68X Monocoque Advanced Twin Mold Technology, ARG2, Tapered Headtube, PressFit BB, Boost 12x148mm, Integrated Cable Routing
SIZE# 6", 18", 20", 22"
FORK# Fox 32 Float SC FIT4 Factory, Tapered, 15x110mm, Kashima Coated, 100mm, 2-Position Remote Lever

HEADSET# Acros AzX/AiX, block lock, Top: semi 1 1/8", Bottom: 1 1/2"
STEM# Newmen Evolution SL 318.2, 31.8mm
HANDLEBAR# Newmen Advanced SL 318.0, Carbon, 740mm
GRIPS# CUBE Race SL Grip 29.5mm, 1-Clamp
REAR DERAILLEUR# Sram XX1 Eagle AXS™, 12-Speed
SHIFTERS# Sram Eagle AXS™ Controller
BRAKE SYSTEM# Sram Level Ultimate, Hydr. Disc Brake (180/160)
CRANKSET# Sram XX1 Eagle™ DUB, 34T, 175mm (smallest Size 170mm)
CASSETTE# Sram XG-1299 Rainbow, 10-50T
WHEELSET# Newmen Advanced SL X.25 Carbon, 28/28 Spokes, 15x110mm/12x148mm, Tubeless Ready
FRONT TIRE# Schwalbe Racing Ray, Addix Speedgrip, Kevlar, 2.25, LiteSkin
REAR TIRE# Schwalbe Racing Ralph, Addix Speed, Kevlar, 2.25, LiteSkin
SADDLE# Natural Fit Nuance SLT
SEAT POST# Newmen Advanced, Carbon, 27.2mm
SEATCLAMP# CUBE Superlight, 30.8mm

WEIGHT# 6 kg



11292
CUBE SLT JERSEY



11294
CUBE SLT BIB SHORTS



93319
ACID BOTTLE CAGE HPC

SPARE PARTS#
8651 CUBE HANGER_mtb-x12-std-2020 [18-05516]

HARDTAIL

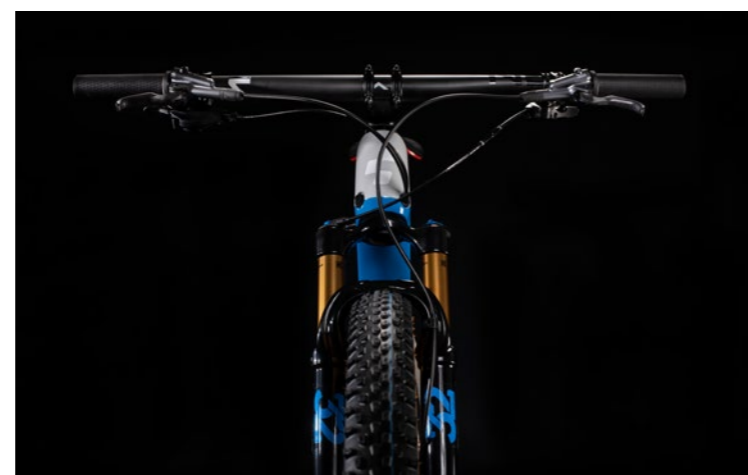

10940
CUBE TEAMLINE JERSEY



10943
CUBE TEAMLINE SHORTS



17089
CUBE SHOES MTB C:62 SLT

We don't put our Teamline colours on any old bike. It's a good thing, then, that the brand-new Elite C:68X SL Teamline is far from any old bike. With a completely revised frame that's 15% lighter than the one it replaces, our design team has been putting in the hours to build a marathon-focussed cross-country hardtail worthy of wearing our team livery. Starting with our next-generation C:68X carbon technology and a blank sheet of paper, they carefully shaved weight where possible while ensuring strength and efficiency weren't sacrificed. So the tapered head tube, carefully profiled down tube and Boost 148 rear end ensure that every watt of your pedalling input is transferred to the rear wheel. In the meantime, slim seat stays and a 27.2mm seat post contribute to a ride that's comfortable for extended periods, aided and abetted by the Fox Float Factory suspension fork. Light, strong Newmen Advanced carbon wheels shod with grippy, fast-rolling Schwalbe tyres give you the control you need in combination with our tweaked Agile Ride Geometry, and a full complement of Shimano's superb XTR 1x12 components take care of stop-and-go duties with typically reliable alacrity. Ride fast, ride far and ride well. It's what our team riders do – and you can, too, with this bike.

FRAME#C:68X Monoque Advanced Twin Mold Technology, ARG2, Tapered Headtube, PressFit BB, Boost 12x148mm, Integrated Cable Routing
SIZE#6", 18", 20", 22"
FORK#Fox 32 Float SC FIT4 Factory, Tapered, 15x110mm, Kashima Coated, 100mm, 2-Position Remote Lever

HEADSET#Acros AzX/AiX, block lock, Top: semi 1 1/8", Bottom: 1 1/2"
STEM#Newmen Evolution SL 318.2, 31.8mm
HANDLEBAR#Newmen Advanced SL 318.0, Carbon, 740mm
GRIPS#CUBE Race SL Grip 29.5mm, 1-Clamp
REAR DERAILLEUR#Shimano XTR RD-M9100-SGS, ShadowPlus, 12-Speed
SHIFTERS#Shimano XTR SL-M9100-I Direct Attach
BRAKE SYSTEM#Shimano XTR BR-M9100, Hydr. Disc Brake (180/160)
CRANKSET#Shimano XTR FC-M9100-1, 34T, 175mm (smallest Size 170mm)
CASSETTE#Shimano XTR CS-M9100-12, 10-51T
CHAIN#Shimano CN-M9100
WHEELSET#Newmen Advanced SL X.25 Carbon, 28/28 Spokes, 15x110mm/12x148mm, Tubeless Ready
SADDLE#Natural Fit Nuance SLT
SEAT POST#Newmen Advanced, Carbon, 27.2mm
SEATCLAMP#CUBE Superlight, 30.8mm

WEIGHT#7 kg

SPARE PARTS#
8651 CUBE HANGER_mtb-x12-std-2020 (18-05516)

ELITE C:68X RACE

317100 carbon'n'glossy



Our brand-new Elite C:68X Race is many things. An uncompromisingly high-performance carbon speed machine? Certainly. A cross-country hardtail built with an eye on weight reduction? Definitely. A marathon-specific bike designed to be comfortable and agile over longer distances? Yes, that too. Given the chance to build a brand-new frame crafted from our next generation C:68X carbon, our engineers took the opportunity to refine what was already a widely admired cross-country thoroughbred. The result is a chassis that's 15% lighter than the one it replaces, but every bit as efficient at translating rider effort into rapid forward progress. The tapered head tube, Boost 148 rear end and carefully profiled down tube ensure incredible pedalling efficiency, while slender seat stays and a narrow 27.2mm seat post add noticeable rider comfort to the mix. We've tweaked the Agile Ride Geometry, too, with a slightly slacker head angle for more relaxed handling. With Sram's 1x12 X01 Eagle transmission and Level Ultimate hydraulic disc brakes, it's ready for the start line. Newmen wheels and fast-rolling Schwalbe tyres hook up well on a range of trail surfaces, while RockShox's iconic SID Ultimate fork takes care of keeping the front wheel planted and pointed in the right direction. It's all you need for a day's racing... or simply a day out in the hills, riding hard and fast.

FRAME C:68X Monocoque Advanced Twin Mold Technology, ARG2, Tapered Headtube, PressFit BB, Boost 12x148mm, Integrated Cable Routing, Dropper Post ready
SIZE #6", 18", 20", 22"
FORK RockShox SID Ultimate RLC, Carbon, Fast Black, Tapered, 15x110mm, 100mm, OneLoc

HEADSET #Acros AzX/AiX, block lock, Top: semi 1 1/8", Bottom: 1 1/2"
STEM #Newmen Evolution SL 318.4, 31.8mm
HANDLEBAR #Newmen Advanced 318.0, Carbon, 740mm
REAR DERAILLEUR #Sram X01 Eagle™, 12-Speed
SHIFTERS #Sram X01 Eagle™ Trigger
BRAKE SYSTEM #Sram Level Ultimate, Hydr. Disc Brake (180/160)
CRANKSET #Sram XX1 Eagle™ DUB, 34T, 175mm (smallest Size 170mm)
CASSETTE #Sram XG-1295, 10-50T
CHAIN #Sram PC-X01 Eagle™
WHEELSET #Newmen Evolution SL X.A.25, 28/28 Spokes, 15x110mm / 12x148mm, Tubeless Ready
FRONT TIRE #Schwalbe Racing Ray, Addix Speedgrip, Kevlar, 2.25, LiteSkin
REAR TIRE #Schwalbe Racing Ralph, Addix Speed, Kevlar, 2.25, LiteSkin
SADDLE #Natural Fit Nuance SLT
SEAT POST #Newmen Advanced, Carbon, 27.2mm
SEATCLAMP #CUBE Superlight, 30.8mm

WEIGHT #3 kg

SPARE PARTS
8651 CUBE HANGER_mtb-x12-std-2020 [18-05516]

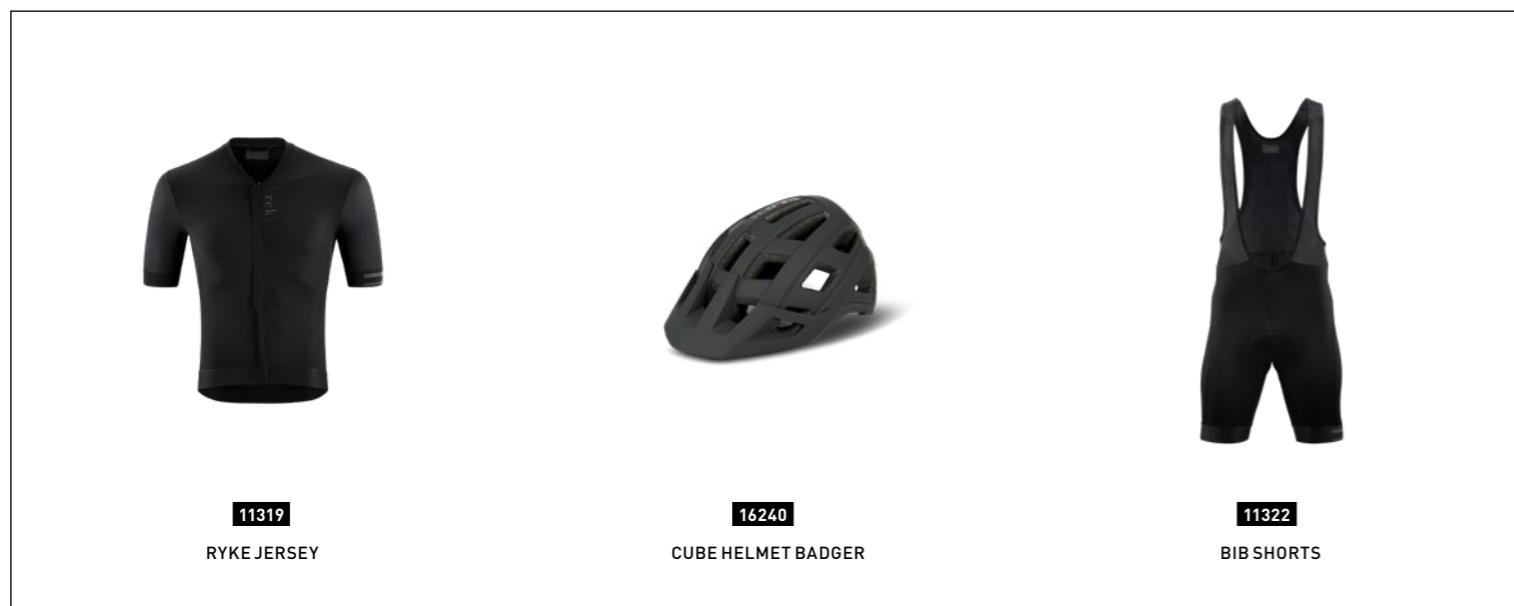

11319
RYKE JERSEY



16240
CUBE HELMET BADGER



11322
BIB SHORTS

FOR us #XC-Pilots

The Reaction C:62's frame condenses everything our engineering team has learnt about high-performance carbon frame construction into a light, strong and impressively responsive chassis. Crafted from our premium C:62 carbon using our Advanced Twin Mold manufacturing process, it's a masterpiece of minimalist perfection. The short rear end with Boost thru axle and Agile Ride Geometry creates a lively, responsive ride feel while an integrated headset and PressFit bottom bracket save precious grammes without sacrificing performance. Slim seat stays and a 27.2mm seat post help ensure you'll stay comfortable for longer, even when you're giving it your all. And internal cable routing keeps gear shifts clean and precise in even the worst riding conditions, reducing the need for maintenance and ensuring you never miss a shift. We even remembered to include cable routing for a dropper post, should you wish to upgrade in the future. And everything is designed to be as light as possible – because less, after all, is more. Less weight means more speed...



REACTION C:62 SLT

316500 carbon 'n' silver



If you've been looking for the best in lightweight, race-bred hardtails, your search is over. With its light, agile and responsive C:62 carbon frameset and completely uncompromising component selection, the Reaction C:62 SLT is the bike to head up your race machine wish-list. The Boost rear end, tapered head tube and carefully profiled top and down tubes work together to deliver exceptional torsional rigidity for more accurate steering and efficient power transfer. But refined frame details and responsive geometry aren't enough on their own – we know that you also need components that won't let you down. That's why we selected only the best of the best for this speed machine. From Sram's X01 1x12 Eagle transmission to the Magura MT8 Pro hydraulic disc brakes, Newmen wheelset and RockShox SID Ultimate fork, we simply gave our product managers free rein to make the right choices. The Sram carbon crankset and Newmen carbon cockpit are the icing on a particularly sweet cake. It all adds up to blisteringly quick performance, race after race, ride after ride. Whether you're chasing your buddies or another podium, the Reaction C:62 SLT won't let you down.

FRAME#C:62 MonoCoque Advanced Twin Mold Technology, ARG2, Tapered Headtube, PressFit BB, Boost 12x148mm, Integrated Cable Routing, Dropper Post Ready
SIZE#5", 17", 19", 21", 23"
FORK#RockShox SID Ultimate RLC, Fast Black, Tapered, 15x110mm, 100mm, OneLoc

HEADSET#SA Orbit I-t, Integrated, Top 1 1/8", Bottom 1 1/2"
STEM#Newmen Evolution 318.4, 31.8mm
HANDLEBAR#Newmen Advanced 318.0, Carbon, 740mm
GRIPS#CUBE Race SL Grip 29.5mm, 1-Clamp
REAR DERAILLEUR#Sram X01 Eagle™, 12-Speed
SHIFTERS#Sram X01 Eagle™ Trigger
BRAKE SYSTEM#Magura MT8 Pro, Hydr. Disc Brake [180/160]
CRANKSET#Sram X1 Eagle™ Carbon DUB 32T, 175mm
CASSETTE#Sram XG-1275, 10-50T
CHAIN#Sram GX Eagle™
WHEELSET#Newmen Evolution SL X.A.25, 28/28 Spokes, 15x110mm/12x148mm, Tubeless Ready
FRONT TIRE#Schwalbe Racing Ray, Addix Speedgrip, Kevlar, 2.25, LiteSkin
REAR TIRE#Schwalbe Racing Ralph, Addix Speed, Kevlar, 2.25, LiteSkin
SADDLE#Natural Fit Nuance SL
SEAT POST#Newmen Advanced, Carbon, 27.2mm
SEATCLAMP#CUBE Varioclose, 31.8mm

WEIGHT#6 kg

SPARE PARTS#
8651 CUBE HANGER_mtb-x12-std-2020 [18-05516]



11074

CUBE BLACKLINE BAGGY BIB SHORTS



11071

CUBE BLACKLINE JERSEY



12095

CUBE BACKPACK PURE 4 RACE

REACTION C:62 SL

316400 greyblue'n'green



If you fancy the idea of leaving your competition in the dust, may we suggest the Reaction C:62 SL as a good starting point? With its light, stiff and responsive frame – built from our premium C:62 carbon – and a selection of components that won't let you down in the thick of the race action, it's the best way of ensuring that other riders only ever get to see your back disappearing into the distance. Race-inspired geometry built around a short, Boost axle-equipped rear end provides exceptional drivetrain rigidity and sharp handling thanks to our Agile Ride Geometry, while narrow seat stays and a slender 27.2mm seat post help reduce fatigue. There's a full Shimano XT 1x12 transmission with matching hydraulic disc brakes for precise shifting and powerful stopping, a light but strong Fulcrum wheelset shod with grippy Schwalbe tyres, a Fox Float 32 fork to keep the front wheel planted and tracking straight, and a Newmen carbon handlebar for even lower weight and greater comfort. All this premium kit and unsurpassed attention to detail is there for one reason, and one reason only: so that you can get on with the job of leading from the front.

FRAME# C:62 Monocoque Advanced Twin Mold Technology, ARG2, Tapered Headtube, PressFit BB, Boost 12x148mm, Integrated Cable Routing, Dropper Post Ready
SIZE# 5", 17", 19", 21", 23"
FORK# Fox 32 Float Performance Elite SC, Tapered, 15x110mm, 100mm, 2-Position Remote Lever

HEADSET# SA Orbit I-t, Integrated, Top 1 1/8", Bottom 1 1/2"
STEM# Newmen Evolution 318.4, 31.8mm
HANDLEBAR# Newmen Advanced 318.0, Carbon, 740mm
GRIPS# CUBE Race SL Grip 29.5mm, 1-Clamp
REAR DERAILLEUR# Shimano XT RD-M8100-SGS, ShadowPlus, 12-Speed
SHIFTERS# Shimano XT SL-M8100-IR, Direct Attach
BRAKE SYSTEM# Shimano XT BR-M8100, Hydr. Disc Brake (180/160)
CRANKSET# Shimano XT FC-M8100, Boost, 32T, 175mm
CASSETTE# Shimano XT CS-M8100, 10-51T
CHAIN# Shimano CN-M7100
WHEELSET# Fulcrum Red 77, 28/28 Spokes, 15x110mm/12x148mm, Tubeless Ready
FRONT TIRE# Schwalbe Racing Ray, Addix Performance, Kevlar, 2.25
REAR TIRE# Schwalbe Racing Ralph, Addix Performance, Kevlar, 2.25
SADDLE# Natural Fit Venec
SEAT POST# Newmen Evolution, 27.2mm
SEATCLAMP# CUBE Varioclose, 31.8mm

WEIGHT# 0,4 kg



13019
CUBE BOTTLE CAGE HPP



16290
CUBE HELMET QUEST



11013
CUBE BLACKLINE JERSEY

SPARE PARTS#
8651 CUBE HANGER_mtb-x12-std-2020 [18-05516]

REACTION C:62 RACE 2X12

316310 grey'n'orange



14226
RFR PEDALS CLICK MTB RACE

17072
CUBE SHOES MTB PEAK

13022
CUBE BOTTLE CAGE HPP

The Reaction C:62 Race exudes racing flair from every frame tube and each component – which is why it's earned the Race tag. And yes, it's every bit as fast as it looks. Its elegant chassis condenses everything our engineering team has learnt about high-performance carbon frame construction into a light, strong and responsive frame. From the short chain stays and Boost rear axle to the slender, vibration-absorbing seat stays and tapered head tube, every detail is honed for speed and efficiency. Which means, of course, that we didn't skimp on the components – it has everything an aspiring racer could possibly need for a season of podium-chasing. A Fox Float 32 fork with remote lockout, Shimano's wide-ranging 2x12 XT transmission and hydraulic disc brakes, CUBE wheelset shod with Schwalbe tyres and Newmen cockpit components leave no room for doubt: this is a bike that will allow you to perform at your very best. Are you ready to push the limits of your performance? Because the Reaction C:62 Race most definitely is...

FRAME #62 Monocoque Advanced Twin Mold Technology, ARG2, Tapered Headtube, PressFit BB, Boost 12x148mm, Integrated Cable Routing, Dropper Post Ready
SIZE #5", 17", 19", 21", 23"
FORK #Fox 32 Rhythm, Tapered, 15x110mm, 100mm, 2-Position Remote

HEADSET #SA Orbit I-t, Integrated, Top 1 1/8", Bottom 1 1/2"
STEM #Newmen Evolution 318.4, 31.8mm
HANDLEBAR #Newmen Evolution 318.10, 720mm
GRIPS #CUBE Race SL Grip 29.5mm, 1-Clamp
REAR DERAILLEUR #Shimano XT RD-M8120-SGS, ShadowPlus, 12-Speed
SHIFTERS #Shimano XT SL-M8100-IR, Direct Attach
FRONT DERAILLEUR #Shimano XT FD-M8100-E, E-Type, Side Swing
BRAKE SYSTEM #Shimano XT BR-M8100, Hydr. Disc Brake (180/160)
CRANKSET #Shimano SLX FC-M7120-B2, Boost, 36x26T, 175mm
CASSETTE #Shimano XT CS-M8100, 10-45T
CHAIN #Shimano CN-M7100
RIMS #CUBE EX21, 32H, Disc, Tubeless Ready
FRONT HUB #Shimano HB-MT400-B, 15mm, Boost, Centerlock
REAR HUB #Shimano FH-MT510-B, Boost, Through Axle, Centerlock
FRONT TIRE #Schwalbe Racing Ray, Addix Performance, Kevlar, 2.25
REAR TIRE #Schwalbe Racing Ralph, Addix Performance, Kevlar, 2.25
SADDLE #Natural Fit Venec
SEAT POST #Newmen Evolution, 27.2mm
SEATCLAMP #CUBE Varioclose, 31.8mm

WEIGHT #1,3 kg

SPARE PARTS#
8651 CUBE HANGER_mt看-x12-std-2020 (18-05516)
10339 CUBE Headset Orbit I-T + 1 1/8 crown race
13457 RFR Seatclamp with Quick Release 34,9 mm

REACTION C:62 RACE

316300 grey'n'orange



The Reaction C:62 Race exudes racing flair from every frame tube and each component – which is why it's earned the Race tag. And yes, it's every bit as fast as it looks. Its elegant chassis condenses everything our engineering team has learnt about high-performance carbon frame construction into a light, strong and responsive frame. From the short chain stays and Boost rear axle to the slender, vibration-absorbing seat stays and tapered head tube, every detail is honed for speed and efficiency. Which means, of course, that we didn't skimp on the components – it has everything an aspiring racer could possibly need for a season of podium-chasing. A RockShox Reba with remote lockout, Sram's legendary 1x12 transmission and Shimano XT hydraulic disc brakes, Answer Attack wheelset shod with Schwalbe tyres and Newmen cockpit components leave no room for doubt: this is a bike that will allow you to perform at your very best. Are you ready to push the limits of your performance? Because the Reaction C:62 Race most definitely is...

FRAME# C:62 Monocoque Advanced Twin Mold Technology, ARG2, Tapered Headtube, PressFit BB, Boost 12x148mm, Integrated Cable Routing, Dropper Post Ready
SIZE# 5", 17", 19", 21", 23"
FORK# RockShox Reba RL Air, Tapered, 15x110mm, 100mm, Oneloc

HEADSET# SA Orbit I-t, Integrated, Top 1 1/8", Bottom 1 1/2"
STEM# Newmen Evolution 318.4, 31.8mm
HANDLEBAR# Newmen Evolution 318.10, 720mm
GRIPS# CUBE Race SL Grip 29.5mm, 1-Clamp
REAR DERAILLEUR# Sram GX Eagle™, 12-Speed
SHIFTERS# Sram GX Eagle™ Trigger
BRAKE SYSTEM# Shimano XT BR-M8100, Hydr. Disc Brake (180/160)
CRANKSET# Sram Stylo Eagle™ 6K DUB 32T, 175mm
CASSETTE# Sram XG-1275, 10-50T
CHAIN# Sram GX Eagle™
WHEELSET# Answer Attack AM, 15x110mm/12x142mm, Tubeless-Ready
FRONT TIRE# Schwalbe Racing Ray, Addix Performance, Kevlar, 2.25
REAR TIRE# Schwalbe Racing Ralph, Addix Performance, Kevlar, 2.25
SADDLE# Natural Fit Venec
SEAT POST# Newmen Evolution, 27.2mm
SEATCLAMP# CUBE Varioclose, 31.8mm

WEIGHT# 0,7 kg



13212
RFR GRIPS PRO HPP



10585
CUBE BASELAYER RACE BE WARM



16287
CUBE HELMET QUEST

SPARE PARTS#
8651 CUBE HANGER_mtb-x12-std-2020 [18-05516]

REACTION C:62 PRO

316100 carbon'n'blue



REACTION C:62 PRO

316110 red'n'orange

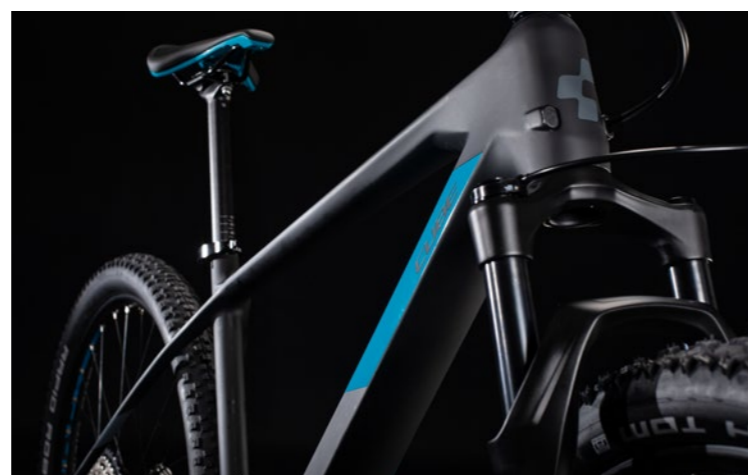

The Reaction series represents something rather special – it's CUBE's Formula One class of mountain bikes. Light, stiff, responsive and built for one purpose only: to get from A to B as quickly as possible. To that end, we've poured all our accumulated carbon frame-building experience into it. Short chain stays, a Boost thru axle at the rear and tapered head tube up front all contribute to impressive steering accuracy and incredibly efficient pedalling, all wrapped up in our Agile Ride Geometry for impeccable control. Fast-rolling 29er wheels make light work of the trail, aided and abetted by slender seat stays for more comfort and a RockShox Judy air fork for superb control in the rough. We even incorporated cable routing for a stealth dropper post upgrade, if that's where your ambitions take you. And, as you'd expect, our design team selected Shimano's superb 1x12 XT and SLX components for their unparalleled gear range and legendarily smooth, reliable performance. It's all set to take on any cross-country challenge, but it's missing one vital component: you.

FRAME# C:62 MonoCoque Advanced Twin Mold Technology, ARG2, Tapered Headtube, PressFit BB, Boost 12x148mm, Integrated Cable Routing, Dropper Post Ready
SIZE# 5", 17", 19", 21", 23"
FORK# RockShox Judy Silver TK AIR, 100mm, PopLoc, 15x110mm

HEADSET# SA Orbit I-t, Integrated, Top 1 1/8", Bottom 1 1/2"
STEM# CUBE Performance Stem Pro, 31.8mm
HANDLEBAR# CUBE Flat Race Bar, 720mm
GRIPS# CUBE Performance Grip
REAR DERAILLEUR# Shimano XT RD-M8100-SGS, ShadowPlus, 12-Speed
SHIFTERS# Shimano SLX SL-M7100-I Direct Attach
BRAKE SYSTEM# Shimano XT BR-M8100, Hydr. Disc Brake (180/160)
CRANKSET# Shimano FC-MT610, 32T, 175mm
CASSETTE# Shimano SLX CS-M7100, 10-51T
CHAIN# Shimano CN-M7100
RIMS# CUBE EX21, 32H, Disc, Tubeless Ready
FRONT HUB# Shimano HB-MT400-B, 15mm, Boost, Centerlock
REAR HUB# Shimano FH-MT510-B, Boost, Through Axle, Centerlock
FRONT TIRE# Schwalbe Tough Tom, Active, 2.25
REAR TIRE# Schwalbe Rapid Rob, Active, 2.25
SADDLE# Natural Fit Venec
SEAT POST# CUBE Performance Post, 27.2mm
SEATCLAMP# CUBE Varioclose, 31.8mm

WEIGHT# 1,9 kg



11272
CUBE GRIPS RACE SL

10753
CUBE EDGE LIGHTWEIGHT SHORTS

16169
CUBE HELMET ROOK

SPARE PARTS#
8651 CUBE HANGER_mtb-x12-std-2020 (18-05516)
10339 CUBE Headset Orbit I-T + 1 1/8 crown race

FOR us #XC-Pilots

What do you need in a great-handling, versatile hardtail? Well, it needs to be light and stiff for starters. That's why we began with mechanically formed, double-butted 6061 aluminium main frame tubes combined with a tapered head tube. Taken together they form a rigid backbone for the rest of the frame, carefully tailored with our Agile Ride Geometry to build a chassis that's responsive and accurate. Then we took a close look at the luggage carrier and mudguard mounting points, making them even neater than before so that you can add the accessories you need easily and, just as importantly, without ruining the clean lines of your bike. Details, see? They're what make a CUBE.



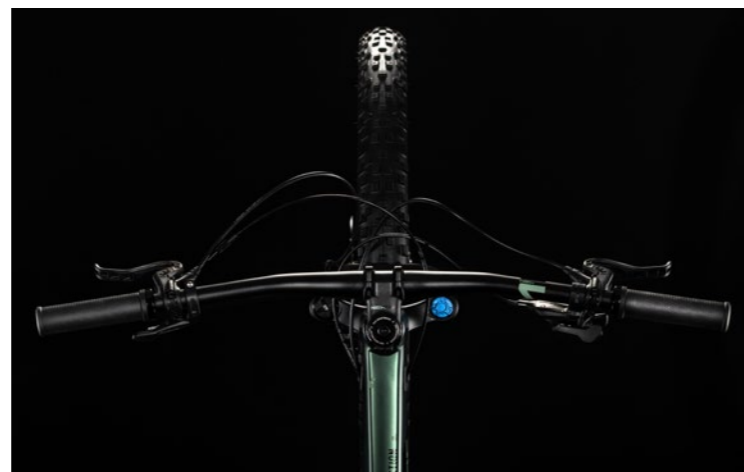

We wanted to make something a bit special with our Reaction™. A trail-ready hardtail with a dose of attitude, it's got everything you need to push your trail riding to the next level. With 2.6in tyres and an X-Fusion RC32 fork with thru axle and 130mm of smooth, easily adjusted travel, you can tell right away that this is a bike that's up for a challenge. The frame's built for the job, with a rear thru axle, tapered head tube and complex-profile, hydroformed main frame tubes for exactly the right combination of stiffness, strength and comfort. The Newmen cockpit with 760mm handlebar gives you the confidence and extra control you need on the toughest of trails, while powerful Magura MT Thirty hydraulic disc brakes ensure you can always scrub off speed when you need to. Sram's simple, reliable and extraordinarily wide-ranging 1x12 transmission puts the right gear for any situation within easy reach, and we even fitted a dropper post so you're ready for those pulse-quickenning line choices. Bring it on, because the Reaction™ is ready. Are you?

FRAME# Aluminium Lite, Trail Motion Geometry, AMF, ARG, Internal Cable Routing, Easy Mount Kickstand Ready, Tapered Headtube, Press Fit BB, Fits up to 2.8 27.5" Tyres
SIZE# 6", 18", 20", 22"
FORK# X-Fusion RC32, Tapered, 15x110mm, 130mm

HEADSET# SA Orbit I-t, Integrated, Top 1 1/8", Bottom 1 1/2"
STEM# Newmen Evolution 318.4, 31.8mm
HANDLEBAR# Newmen Evolution 318.20, 760mm
GRIPS# CUBE Race Grip 31mm, 1-Clamp
REAR DERAILLEUR# Sram SX Eagle™, 12-Speed
SHIFTERS# Sram SX Eagle™ Trigger
BRAKE SYSTEM# Magura MT Thirty, Hydr. Disc Brake (180/180)
CRANKSET# Sram X1 1000 Eagle™ DUB 30T, Boost, 175mm
CASSETTE# Sram PG-1210 Eagle™, 11-50T
CHAIN# Sram SX Eagle™
RIMS# Rodi TRYP 35, 32H, Disc, Tubeless ready
FRONT HUB# Shimano HB-MT400-B, 15mm, Boost, Centerlock
REAR HUB# Shimano FH-MT400-B, 12mm, Boost, Centerlock
TYRES# Kenda El Capo, 2.6
PEDALS# CUBE PP MTB
SADDLE# Natural Fit Venec Lite
SEAT POST# CUBE Dropper Post, Handlebar Lever, Internal Cable Routing, 30.9mm, 16" 403x120mm, 18" & 20" 425x130mm, 22" 480x150mm
SEATCLAMP# CUBE Screwlock, 31.8mm

WEIGHT# 3.9 kg

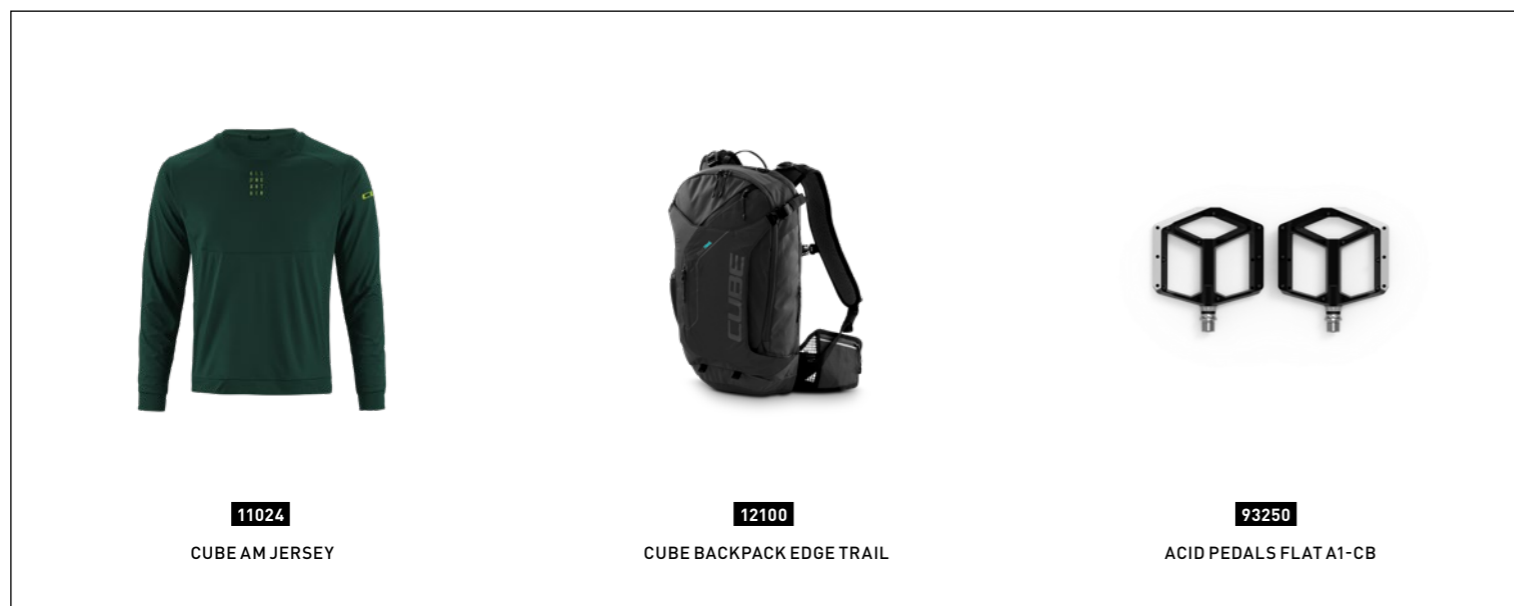

11024
CUBE AM JERSEY

12100
CUBE BACKPACK EDGE TRAIL

93250
ACID PEDALS FLAT A1-CB

SPARE PARTS#
8651 CUBE HANGER_mtb-x12-std-2020 (18-05516)
13545 Inner Tube 27.5"/29" MTB SV 40 mm

REACTION RACE

313100 black 'n' orange



REACTION RACE

313110 green 'n' black



We built the Reaction Race with one thing in mind: speed. Well, OK, maybe three things: speed, comfort and versatility. Features like stealth dropper post compatibility, Agile Ride Geometry and a tapered head tube mean this is a bike that will encourage you to push your skills out in the hills and mountains. The RockShox Judy air fork, big-volume Schwalbe tyres and skinny seat stays all contribute to a ride that's more comfortable than you might expect. Add powerful Shimano Deore hydraulic disc brakes and Sram's hill-devouring 1x12 transmission, and it's all you need for wherever you want to ride. Size Split means there's a perfect fit for any rider. Oh, and did we mention it's designed to go fast?

FRAME Aluminium Lite, AMF, ARG, Internal Cable Routing, Easy Mount Kickstand Ready, Tapered Headtube, PressFit BB
SIZE Size Split: 27.5: 15" // 29: 17", 19", 21", 23"
FORK RockShox Judy Silver TK Air, Fastblack, Tapered, 15x110mm, 100mm, PopLoc

HEADSET SA Orbit I-t, Integrated, Top 1 1/8", Bottom 1 1/2"
STEM CUBE Performance Stem Pro, 31.8mm
HANDLEBAR CUBE Flat Race Bar, 720mm
GRIPS CUBE Performance Grip
REAR DERAILLEUR Sram GX Eagle™, 12-Speed
SHIFTERS Sram GX Eagle™ Trigger
BRAKE SYSTEM Shimano Deore BR-M6000, Hydr. Disc Brake (180/160)
CRANKSET Sram Stylo Eagle™ DUB, 32T, Boost, 175mm
CASSETTE Sram XG-1275, 10-50T
CHAIN Sram NX Eagle™
RIMS CUBE EX21, 32H, Disc, Tubless Ready
FRONT HUB CUBE DHF112
REAR HUB CUBE M5ER Boost
FRONT TIRE Schwalbe Tough Tom, Active, 2.25
REAR TIRE Schwalbe Rapid Rob, Active, 2.25
PEDALS CUBE PP MTB
SADDLE Natural Fit Venec Lite
SEAT POST CUBE Performance Post, 27.2mm
SEATCLAMP CUBE Varioclose, 31.8mm

WEIGHT #2,7 kg

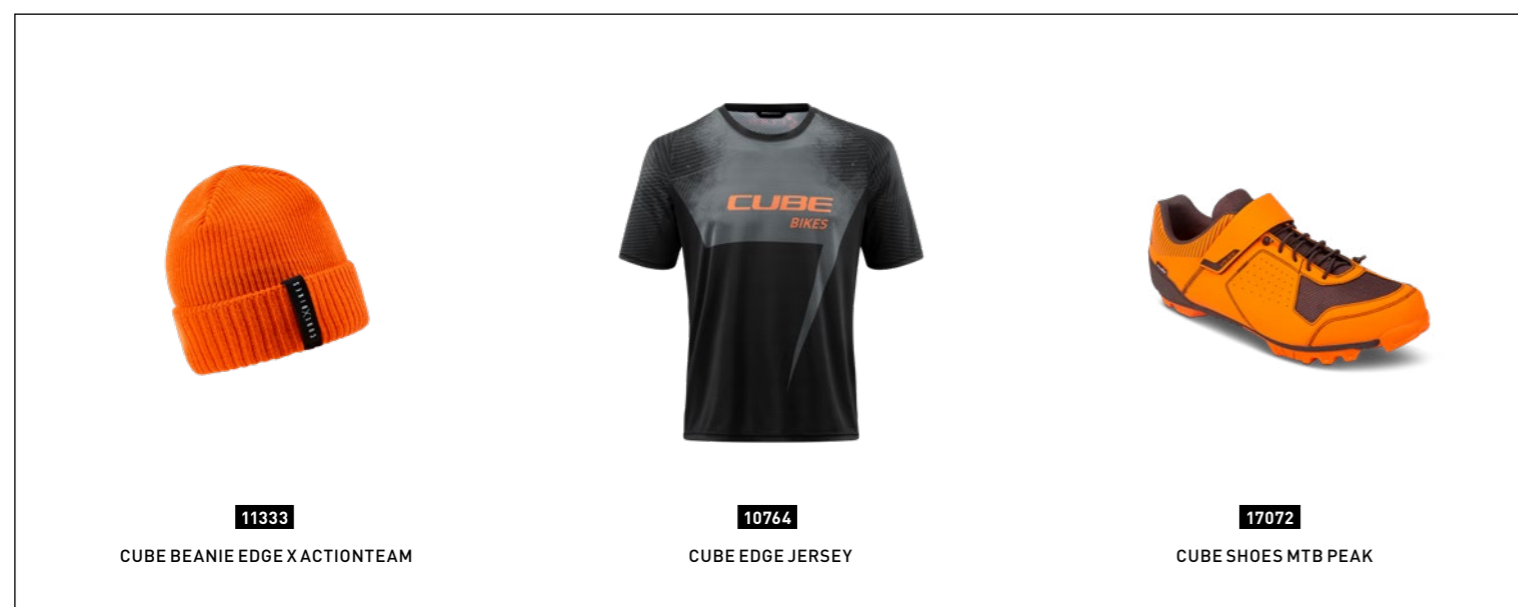

11333
CUBE BEANIE EDGE X ACTIONTEAM

10764
CUBE EDGE JERSEY

17072
CUBE SHOES MTB PEAK

SPARE PARTS
8651 CUBE HANGER_mtb-x12-std-2020 (18-05516)
13462 RFR Seatclamp Ultralight 31,8 mm
13545 Inner Tube 27,5"/29" MTB SV 40 mm

REACTION PRO

312100 black'n'flashyellow



REACTION PRO

312110 blue'n'red



The clue's in the name: Reaction Pro. If you reckon that means we're really getting down to business with this bike, you'd be right. Our popular all-rounder hardtail retains all the features that have made the Reaction a go-to choice for keen riders, like a mechanically formed, double-butted 6061 frame with super-sleek luggage carrier and fender mounts for added versatility. Weekend warrior or weekday commuter (or both) – the Reaction Pro can handle it all. Shimano SLX and XT 1x12 transmission components bring slick reliability and an enormous gear range to our indomitable mid-ranger, putting any climb within easy reach with a system that's easier to use than ever. We fitted a RockShox Recon air fork at the front for added comfort and control, as well as easy adjustability to suit any rider. And with our Size Split system there's bound to be a Reaction Pro that will fit you, whatever your height. This is a bike that's crying out for some fast singletrack action, but just as happy to take you to work: truly, a bike for all reasons.

FRAME Aluminium Lite, AMF, ARG, Internal Cable Routing, Easy Mount Kickstand Ready, Tapered Headtube, PressFit BB
SIZE Size Split: 27.5: 14", 16", 18" // 29: 17", 19", 21", 23"
FORK RockShox Recon Silver TK Air, 100mm, PopLoc

HEADSET CUBE FPH868P, Semi-Integrated
STEM CUBE Performance Stem Pro, 31.8mm
HANDLEBAR CUBE Flat Race Bar, 720mm
GRIPS CUBE Performance Grip
REAR DERAILLEUR Shimano XT RD-M8100-SGS, ShadowPlus, 12-Speed
SHIFTERS Shimano SLX SL-M7100
BRAKE SYSTEM Shimano BR-MT400, Hydr. Disc Brake (180/160)
CRANKSET Shimano XT FC-M8100, Boost, 32T, 175mm
CASSETTE Shimano SLX CS-M7100, 10-51T
CHAIN Shimano CN-M7100
RIMS CUBE EX21, 32H, Disc, Tubeless Ready
FRONT HUB Shimano HB-M4050
REAR HUB Shimano FH-MT500, QR, Centerlock
FRONT TIRE Schwalbe Tough Tom, Active, 2.25
REAR TIRE Schwalbe Rapid Rob, Active, 2.25
PEDALS CUBE PP MTB
SADDLE Natural Fit Venec Lite
SEAT POST CUBE Performance Post, 27.2mm
SEATCLAMP CUBE Varioclose, 31.8mm

WEIGHT 2,9 kg

SPARE PARTS#
8651 CUBE HANGER_mtb-x12-std-2020 (18-05516)
10325 CUBE Headset Orbit Z-t + 1 1/8 crown race
13545 Inner Tube 27,5"/29" MTB SV 40 mm

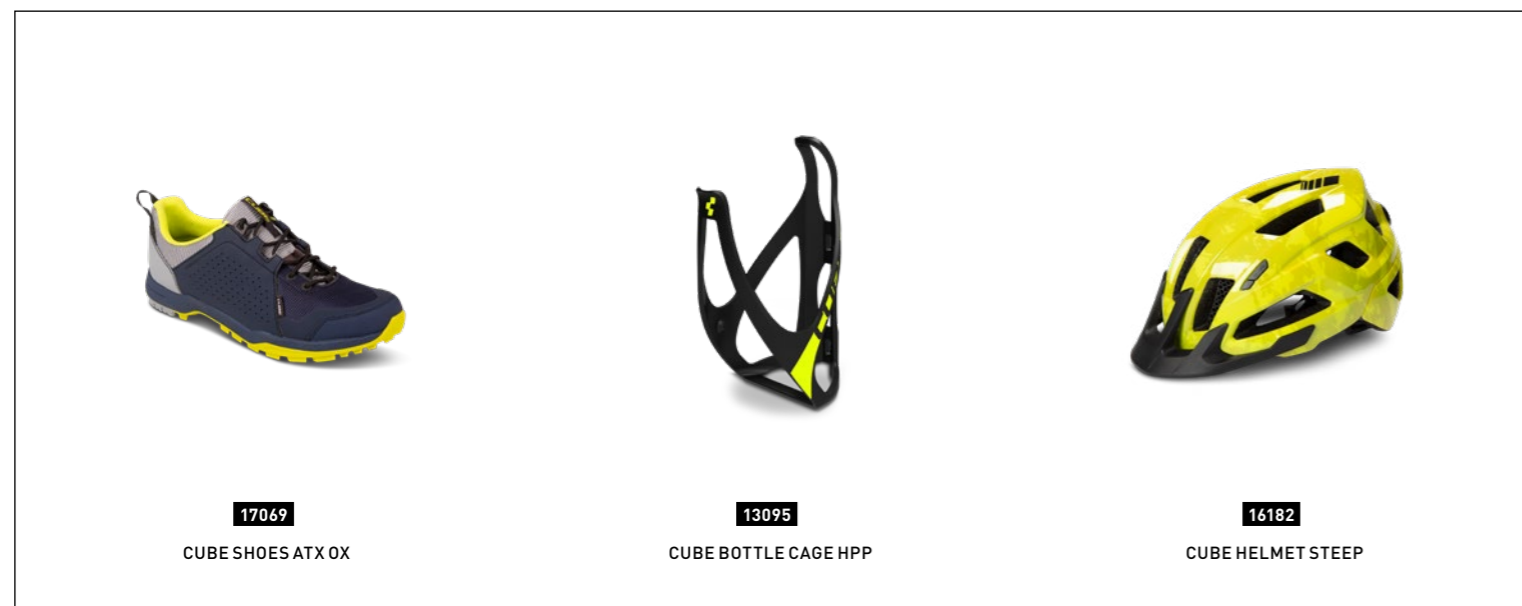

17069
CUBE SHOES ATX OX



13095
CUBE BOTTLE CAGE HPP



16182
CUBE HELMET STEEP

RACE ONE

311100 black'n'green



Not available in all markets.



13712
CUBEGUARD PERFORMANCE 29" REAR

12959
CUBE BOTTLE GRIP 0.75L

16290
CUBE HELMET QUEST

FOR us #MountainBikers

What do you need in a great-handling, versatile hardtail? Well, it needs to be light and stiff for starters. That's why we began with mechanically formed, double-butted 6061 aluminium main frame tubes combined with a tapered head tube. Taken together they form a rigid backbone for the rest of the frame, carefully tailored with our Agile Ride Geometry to build a chassis that's responsive and accurate. Then we took a close look at the luggage carrier and mudguard mounting points, making them even neater than before so that you can add the accessories you need easily and, just as importantly, without ruining the clean lines of your bike. Details, see? They're what make a CUBE.



HARDTAIL



Built to dissolve tricky sections of trail quickly and effortlessly, the Acid is a bike that's more than capable of living up to its name. Featuring a frame that borrows extensively from its high-end cousins, it's designed to help you come out on top of any trail challenge. Precise, accurate steering is assured thanks to a tapered steerer tube and smooth, easily adjustable RockShox Recon air fork. Sram's NX 1x12 Eagle transmission works in harmony with the light, stiff and lively triple-butted frame tubes to propel you down the trail, while powerful Shimano MT400 brakes give you the control you need to bring it all safely to a halt. We even incorporated neatly hidden luggage rack mounting points, so your Acid can do double duty as a weekday urban commuter or weekend tourer too. None of this performance comes at the expense of comfort - big-volume Schwalbe tyres and slender seat stays with a 27.2mm seat post see to that. And, because it's available in a wide range of sizes spanning both 27.5in and 29er wheel standards, there's an Acid with your name on it. Are you ready to accept the challenge?

FRAME Aluminium Lite, AMF, Internal Cable Routing, Easy Mount Kickstand Ready
SIZE Size Split: 27.5: 14", 16", 18" // 29: 17", 19", 21", 23"
FORK RockShox Recon Silver TK Air, 100mm, PopLoc

HEADSET CUBE FPH868P, Semi-Integrated
STEM CUBE Performance Stem Pro, 31.8mm
HANDLEBAR CUBE Rise Trail Bar, 680mm
GRIPS CUBE Performance Grip
REAR DERAILLEUR Sram NX Eagle™, 12-Speed
SHIFTERS Sram NX Eagle™ Trigger
BRAKE SYSTEM Shimano BR-MT400, Hydr. Disc Brake (180/160)
CRANKSET Sram Stylo Eagle™ DUB, 32T, 175mm
CASSETTE Sram XG-1230, 11-50T
CHAIN Sram NX Eagle™
RIMS CUBE SD20, 32H, Disc
FRONT HUB Shimano Deore HB-M6000, Centerlock
REAR HUB Shimano Deore FH-M6000, Centerlock
TYRES Schwalbe Smart Sam, Active, 2.25
PEDALS CUBE PP MTB
SADDLE Natural Fit Venec Lite
SEAT POST CUBE Performance Post, 27.2mm
SEATCLAMP CUBE Varioclose, 31.8mm

WEIGHT #3.3 kg

SPARE PARTS#
10148 CUBE Hanger #148 short version
13543 Inner Tube 27,5"/29" MTB AGV 40 mm

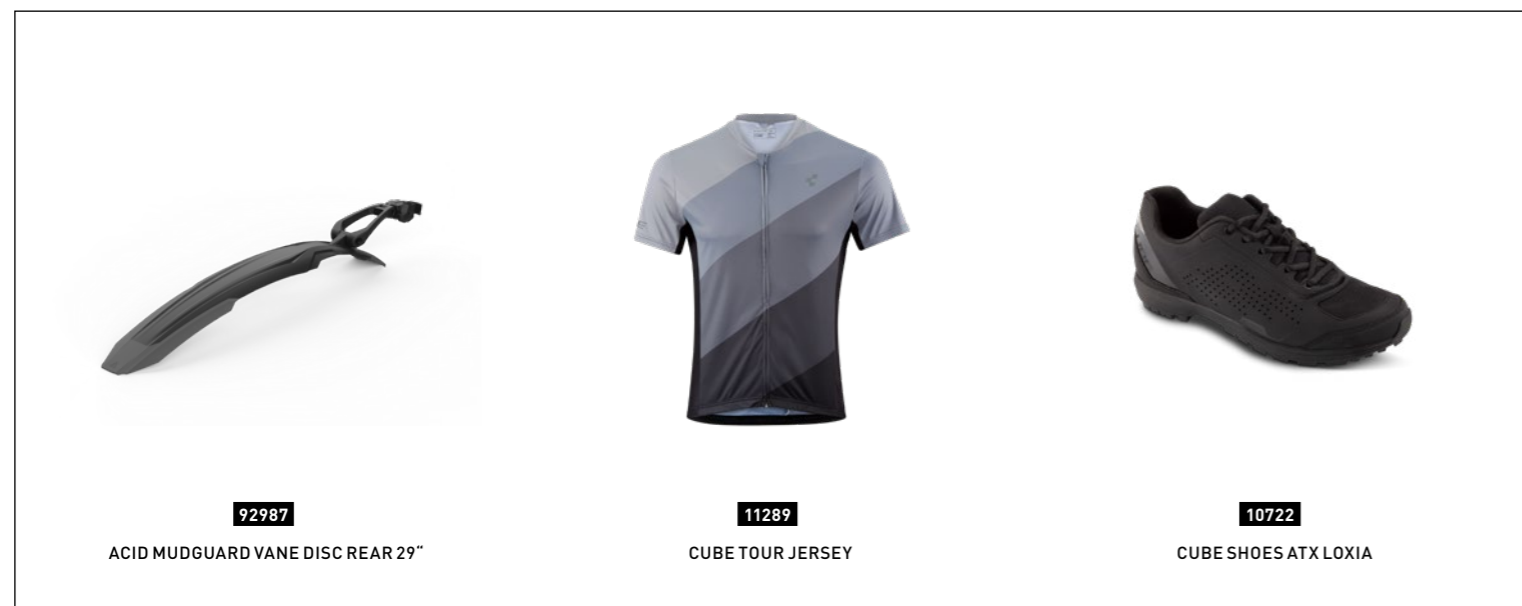

92987
ACID MUDGUARD VANE DISC REAR 29"

11289
CUBE TOUR JERSEY

10722
CUBE SHOES ATX LOXIA

ATTENTION SL

303150 black 'n' blue



ATTENTION SL

303160 orange 'n' black



The SL tag isn't one we use lightly. That's why, with the Attention SL, we set out to create a whole new benchmark for value and performance. Borrowing inspiration and ideas from our high-end race bikes, our product managers started by selecting a RockShox Recon air-sprung fork for the ultimate in easy adjustability and smooth, progressive, bump-swallowing travel. They added powerful Shimano hydraulic disc brakes and a 180mm front rotor for assured stopping in all conditions, and finished off with Shimano SLX 2x11 gear components. And, because the frame is the heart of every bicycle, they lavished the same level of attention to the 6061 aluminium tubes that make up the Attention SL's chassis. Mechanically formed into complex profiles for the ideal combination of strength, stiffness and weight, you can rest assured that it's more than tough enough to pass our stringent in-house lab testing. Agile Ride Geometry means it's nimble and confidence-inspiring, and details like internal cable routing and hidden rack and fender mounts are the icing on the cake. With Size Split sizing guaranteeing a perfect fit for every rider, there's bound to be an Attention SL to suit you.

FRAME Aluminium Lite, AMF, Internal Cable Routing, Easy Mount Kickstand Ready
SIZE Size Split: 27.5: 14", 16", 18" // 29: 17", 19", 21", 23"
FORK RockShox Recon Silver TK SoloAir, 100mm, PopLoc

HEADSET CUBE FPH863, Semi-Integrated
STEM CUBE Performance Stem Pro, 31.8mm
HANDLEBAR CUBE Rise Trail Bar, 680mm
GRIPS CUBE Performance Grip
REAR DERAILLEUR Shimano XT RD-M8000-DSGS, ShadowPlus, 11-Speed
SHIFTERS Shimano SLX SL-M7000
FRONT DERAILLEUR Shimano SLX FD-M7025-H, Downswing, 31.8mm Clamp
BRAKE SYSTEM Shimano BR-MT200, Hydr. Disc Brake (180/160)
CRANKSET Shimano FC-MT600, 36x26T, 175mm
CASSETTE Shimano SLX CS-M7000, 11-42T
CHAIN Shimano CN-HG601-11
RIMS CUBE SD20, 32H, Disc
FRONT HUB Shimano HB-M3050, Centerlock
REAR HUB Shimano FH-M3050, Centerlock
TYRES Schwalbe Smart Sam, Active, 2.25
PEDALS CUBE PP MTB
SADDLE Natural Fit Venec Lite
SEAT POST CUBE Performance Post, 27.2mm
SEATCLAMP CUBE Varioclose, 31.8mm

WEIGHT #3,5 kg



16174
CUBE HELMET PATHOS

11960
CUBE GLOVES XNF

11438
SQUARE JERSEY SPORT

SPARE PARTS
10149 CUBE Hanger #149 long version
13543 Inner Tube 27,5"/29" MTB AGV 40 mm

ATTENTION

303100 grey 'n' green

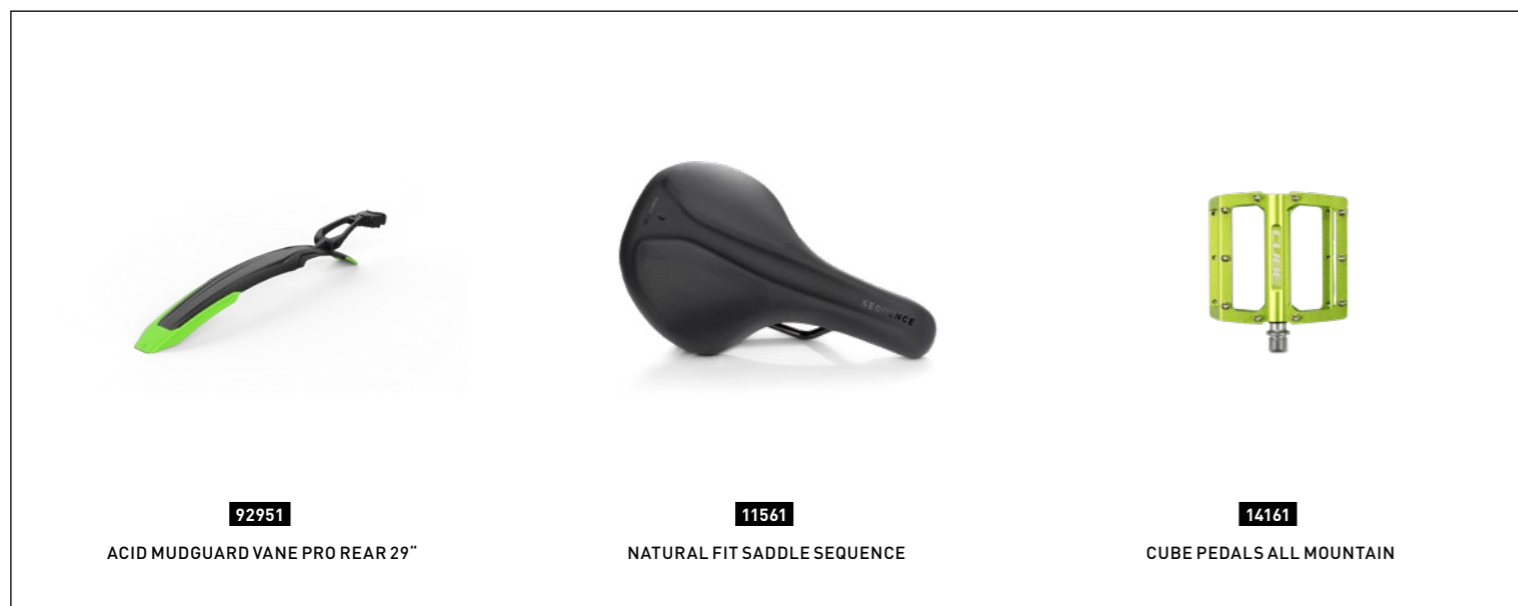
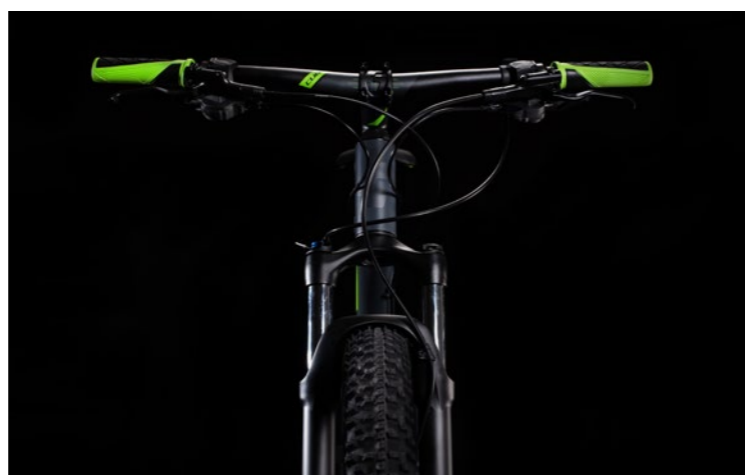

92951
ACID MUDGUARD VANE PRO REAR 29"

11561
NATURAL FIT SADDLE SEQUENCE

14161
CUBE PEDALS ALL MOUNTAIN

ATTENTION

303110 titanium 'n' blue



The Attention is the kind of bike that'll redefine your expectations. Built around a light, responsive, easy-to-handle 6061 aluminium frame, it features the kind of attention to detail you might ordinarily associate with far more expensive bikes. From the internal cable routing – which keeps the appearance tidy and your gears shifting cleanly with minimal maintenance – to the hidden fender and rack mounting system, we've brought high-end looks and functionality to a new level of affordability. The RockShox Reacon XC30 fork adds extra comfort and control, while Shimano's smooth-shifting Deore 2x10-speed transmission with wide-ranging 11-42 tooth cassette puts even the steepest of climbs within your reach. And, of course, we fitted powerful all-weather Shimano hydraulic disc brakes to put you in complete control. With perfect sizing assured thanks to our Size Split system, our Agile Ride Geometry gives you the confidence to tackle any trail. It all adds up to a versatile, easy-to-live-with hardtail that'll slot right into your active lifestyle.

FRAME Aluminium Lite, AMF, Internal Cable Routing, Easy Mount Kickstand Ready
SIZE Size Split: 14", 16", 18" // 29: 17", 19", 21", 23"
FORK RockShox XC 30 TK Coil, 100mm, Remote Lockout

HEADSET CUBE FPH863, Semi-Integrated
STEM CUBE Performance Stem Pro, 31.8mm
HANDLEBAR CUBE Rise Trail Bar, 680mm
GRIPS CUBE Performance Grip
REAR DERAILLEUR Shimano Deore RD-M6000-DGS, ShadowPlus, 10-Speed
SHIFTERS Shimano Deore SL-M6000, Rapidfire-Plus
FRONT DERAILLEUR Shimano Deore FD-M6025-H, Downswing, 31.8mm Clamp
BRAKE SYSTEM Shimano BR-MT200, Hydr. Disc Brake (180/160)
CRANKSET Shimano FC-MT500, 36X26T, 175mm
CASSETTE Shimano Deore CS-HG500, 11-42T
CHAIN Shimano CN-HG54
RIMS CUBE SD20, 32H, Disc
FRONT HUB Shimano HB-M3050, Centerlock
REAR HUB Shimano FH-M3050, Centerlock
TYRES Schwalbe Smart Sam, Active, 2.25
PEDALS CUBE PP MTB
SADDLE Natural Fit Venec Lite
SEAT POST CUBE Performance Post, 27.2mm
SEATCLAMP CUBE Varioclose, 31.8mm

WEIGHT 3,7 kg

SPARE PARTS#
10025 CUBE Disc Brake Pad Shimano Deore BR-M505/15/525/445/446
10149 CUBE Hanger #149 long version
13543 Inner Tube 27,5"/29" MTB AGV 40 mm

ANALOG

302100 black'n'flashyellow



13095

CUBE BOTTLE CAGE HPP



10715

CUBE AM JERSEY



13343

RFR CHAIN COMBINATION LOCK STYLE CMPT

ANALOG

302110 green'n'orange



Caught the mountain bike bug? Then you'll find a willing partner in the Analog. Its high-quality aluminium frame, balanced handling and reliable components add up to a package that's perfect for trail fun. Whether you pick the 27.5in or 29er version, you're assured of a good fit thanks to our Size Split system. Each one is ergonomically tailored to offer a responsive, comfortable ride thanks to our Agile Ride Geometry. The complex-profile top and down tubes – shaped using our proprietary Mechanical Forming process – form a strong, light and safe backbone around which our engineering team has built a light, nimble frame that'll stay the course. Neatly hidden rack and fender mounts make a weekday commuter or weekend tourer conversion quick, simple and elegant. There's a smooth RockShox suspension fork to keep the front wheel tracking straight and true even on rough trails, powerful Shimano hydraulic disc brakes to ensure you're always in control, and Sram's wide-ranging and slick-shifting 1x12 gears to help tame any climb. It's everything you need to explore as far off-road as your curiosity takes you.

FRAME Aluminium Lite, AMF, Internal Cable Routing, Easy Mount Kickstand Ready
SIZE Size Split: 27.5: 14", 16", 18" // 29: 17", 19", 21", 23"
FORK RockShox XC 30 TK Coil, 100mm, Remote Lockout

HEADSET CUBE FPH863, Semi-Integrated
STEM CUBE Performance Stem Pro, 31.8mm
HANDLEBAR CUBE Rise Trail Bar, 680mm
GRIPS CUBE Performance Grip
REAR DERAILLEUR Sram SX Eagle™, 12-Speed
SHIFTERS Sram SX Eagle™ Trigger
BRAKE SYSTEM Shimano BR-MT200, Hydr. Disc Brake (160/160)
CRANKSET Sram SX Eagle™ Powerspline, 32T, 175mm
CASSETTE Sram PG-1210 Eagle™, 11-50T
CHAIN Sram SX Eagle™
RIMS CUBE SD20, 32H, Disc
FRONT HUB Shimano HB-TX505, QR, Centerlock
REAR HUB Shimano FH-TX505, QR, Centerlock
TYRES Schwalbe Smart Sam, Active, 2.25
PEDALS CUBE PP MTB
SADDLE Natural Fit Venec Lite
SEAT POST CUBE Performance Post, 27.2mm
SEATCLAMP CUBE Varioclose, 31.8mm

WEIGHT 3,8 kg

SPARE PARTS#
10025 CUBE Disc Brake Pad Shimano Deore BR-M505/15/525/445/446
10148 CUBE Hanger #148 short version
10324 CUBE Headset Orbit Z
13543 Inner Tube 27,5"/29" MTB AGV 40 mm

AIM SL ALLROAD

301600 black'n'blue



AIM SL ALLROAD

301610 lightgrey'n'green

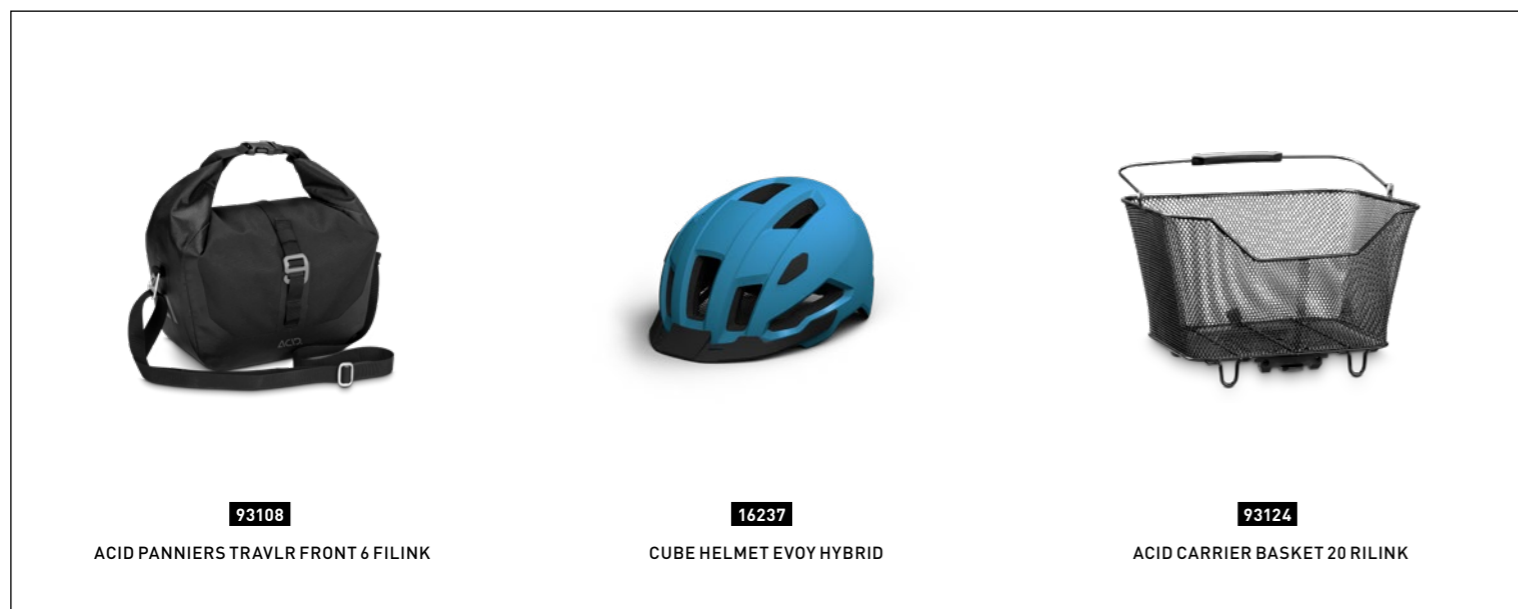

93108
ACID PANNIERS TRAVLR FRONT 6 FILINK

16237
CUBE HELMET EVOY HYBRID

93124
ACID CARRIER BASKET 20 RILINK

Performance and practicality don't have to be mutually exclusive. With our Aim SL Allroad we took all the good things about our range-topping, affordable aluminium hardtail and added mudguards, a luggage carrier, CUBE kickstand and an integrated lighting system for added versatility. Beautifully designed mounting points mean that these practical, essential accessories blend almost seamlessly into the frame's svelte looks, making it as well suited to the urban jungle as it is to forest trails. Agile Ride Geometry and our proprietary Aluminium Lite frame create a bike whose handling is every bit as good as it looks, and with the reassurance of having passed all our stringent in-house safety testing. The Shimano 27-speed gear system offers a huge range of gears and slick, precise shifting with absolutely minimal maintenance, thanks to our neat internal cable routing. An easily configurable Suntour suspension fork, powerful all-weather Shimano hydraulic disc brakes and dynamo-powered lights are the finishing touches. It all adds up to a bike that'll tackle any challenge you care to put its way, whether on road or off. And our Size Split system ensures that, whatever your height, there's an Aim SL Allroad frame and wheel combination that'll fit you perfectly.

FRAME Aluminium Lite, AMF, Internal Cable Routing, Easy Mount Kickstand Ready
SIZE Size Split: 27.5: 14", 16", 18" // 29: 17", 19", 21", 23"
FORK Suntour XCM RL Disc, 100mm, Remote Lockout

HEADSET CUBE FPH863, Semi-Integrated
STEM CUBE Performance Stem Pro, 31.8mm
HANDLEBAR CUBE Rise Trail Bar, 660mm
GRIPS CUBE Performance Grip
REAR DERAILLEUR Shimano Deore RD-M592, 9-Speed
SHIFTERS Shimano SL-M4000, Rapidfire-Plus
FRONT DERAILLEUR Shimano FD-M2000, Downswing, 31.8mm Clamp
BRAKE SYSTEM Shimano BR-MT200, Hydr. Disc Brake (160/160)
CRANKSET Shimano FC-MT101, 40x30x22T, 175mm
CASSETTE Shimano CS-HG400, 12-36T
CHAIN Shimano HG53
RIMS CUBE SD20, 32H, Disc
FRONT HUB Shimano DH-3D37, Hub Dynamo, QR, Centerlock
REAR HUB Shimano FH-TX505, QR, Centerlock
TYRES Schwalbe Smart Sam, Active, 2.25
PEDALS CUBE PP MTB
SADDLE Natural Fit Venec Lite
SEAT POST CUBE Performance Post, 27.2mm
SEATCLAMP CUBE Varioclose, 31.8mm
FRONT LIGHT relock LS592
REAR LIGHT relock LS 613 Duo Flat
KICKSTAND CUBE Stand Pro, Adjustable
MUDGUARDS CID 60
BELL luvo
CARRIER CID Semi-Integrated Carrier, ACID RILink Adapter Compatible and Rail

WEIGHT 6,4 kg

SPARE PARTS
10025 CUBE Disc Brake Pad Shimano Deore BR-M505/15/525/445/446
10148 CUBE Hanger #148 short version
10324 CUBE Headset Orbit Z
13543 Inner Tube 27,5"/29" MTB AGV 40 mm

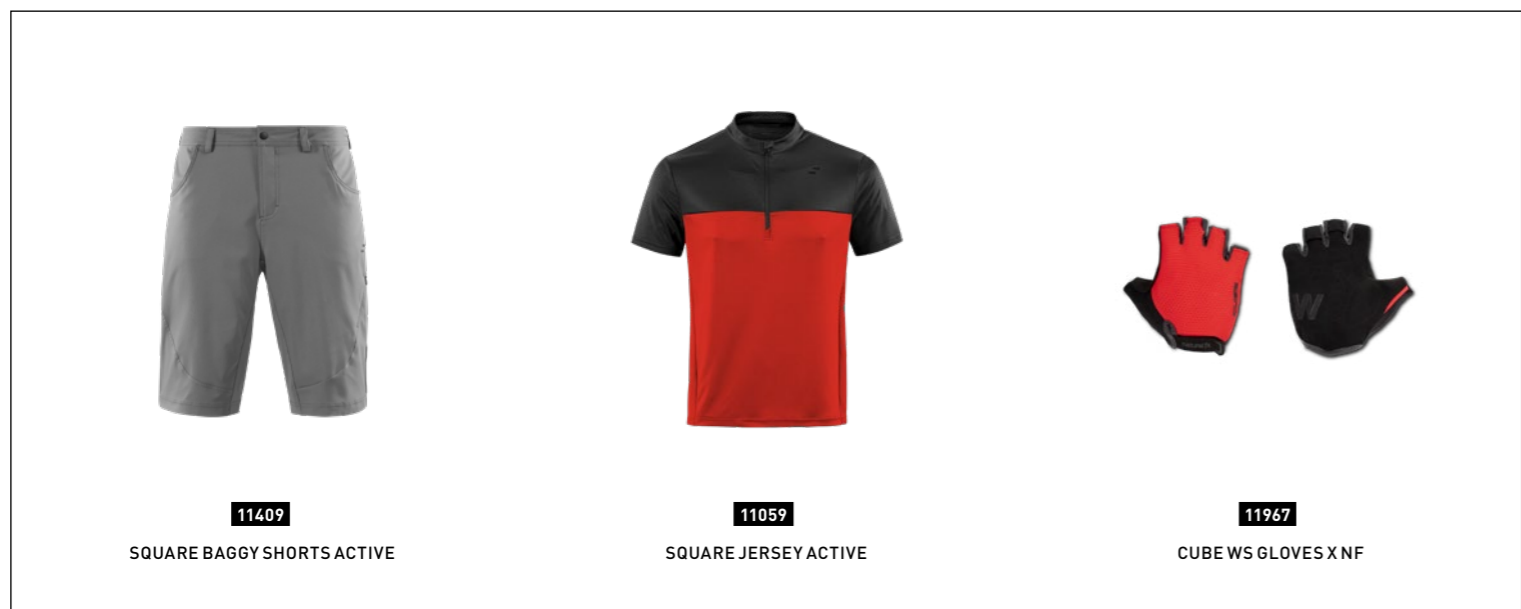

11409 SQUARE BAGGY SHORTS ACTIVE

11059 SQUARE JERSEY ACTIVE

11967 CUBE WS GLOVES X NF



Our range-topping Aim has earned its SL tag. With its high-quality, lightweight and precise-handling aluminium chassis and blend of durable, reliable components, it's the ideal choice for aspiring mountain bikers looking to broaden their trail exploration horizons. Because the frame is the heart of any bicycle, we started with our Aluminium Lite chassis and Agile Ride Geometry for safe, confidence-inspiring handling in any situation. Internal cable routing helps keep the slick-shifting Shimano 27-speed transmission precise and accurate with minimal maintenance, and hidden rack and fender mounts lend an extra dose of everyday practicality. Powerful Shimano hydraulic disc brakes give you the control you need to take on the steepest of descents in any weather conditions, while the smooth Suntour suspension fork – with remote lockout – keeps the front wheel planted and reduces hand and shoulder fatigue even when the going gets rough. It's all you need for exploring off the beaten track, whether it's an evening ride on your local trail or a longer weekend adventure out in the hills. And, with our Size Split system, you're sure to be able to find the perfect fit.

FRAME Aluminium Lite, AMF, Internal Cable Routing, Easy Mount Kickstand Ready
SIZE Size Split: 27.5: 14", 16", 18" // 29: 17", 19", 21", 23"
FORK Suntour XCM RL Disc, 100mm, Remote Lockout

HEADSET CUBE FPH863, Semi-Integrated
STEM CUBE Performance Stem Pro, 31.8mm
HANDLEBAR CUBE Rise Trail Bar, 660mm
GRIPS CUBE Performance Grip
REAR DERAILLEUR Shimano Deore RD-M592, 9-Speed
SHIFTERS Shimano SL-M4000, Rapidfire-Plus
FRONT DERAILLEUR Shimano FD-M2000, Downswing, 31.8mm Clamp
BRAKE SYSTEM Shimano BR-MT200, Hydr. Disc Brake (160/160)
CRANKSET Shimano FC-MT100, 40x30x22T, 175mm
CASSETTE Shimano CS-HG400, 12-36T
CHAIN Shimano HG53
RIMS CUBE SD20, 32H, Disc
FRONT HUB Shimano HB-TX505, QR, Centerlock
REAR HUB Shimano FH-TX505, QR, Centerlock
TYRES Schwalbe Smart Sam, Active, 2.25
PEDALS CUBE PP MTB
SADDLE Natural Fit Venec Lite
SEAT POST CUBE Performance Post, 27.2mm
SEATCLAMP CUBE Varioclose, 31.8mm

WEIGHT 4,1 kg

SPARE PARTS#
10025 CUBE Disc Brake Pad Shimano Deore BR-M505/15/525/445/446
10148 CUBE Hanger #148 short version
10324 CUBE Headset Orbit Z
13543 Inner Tube 27,5"/29" MTB AGV 40 mm

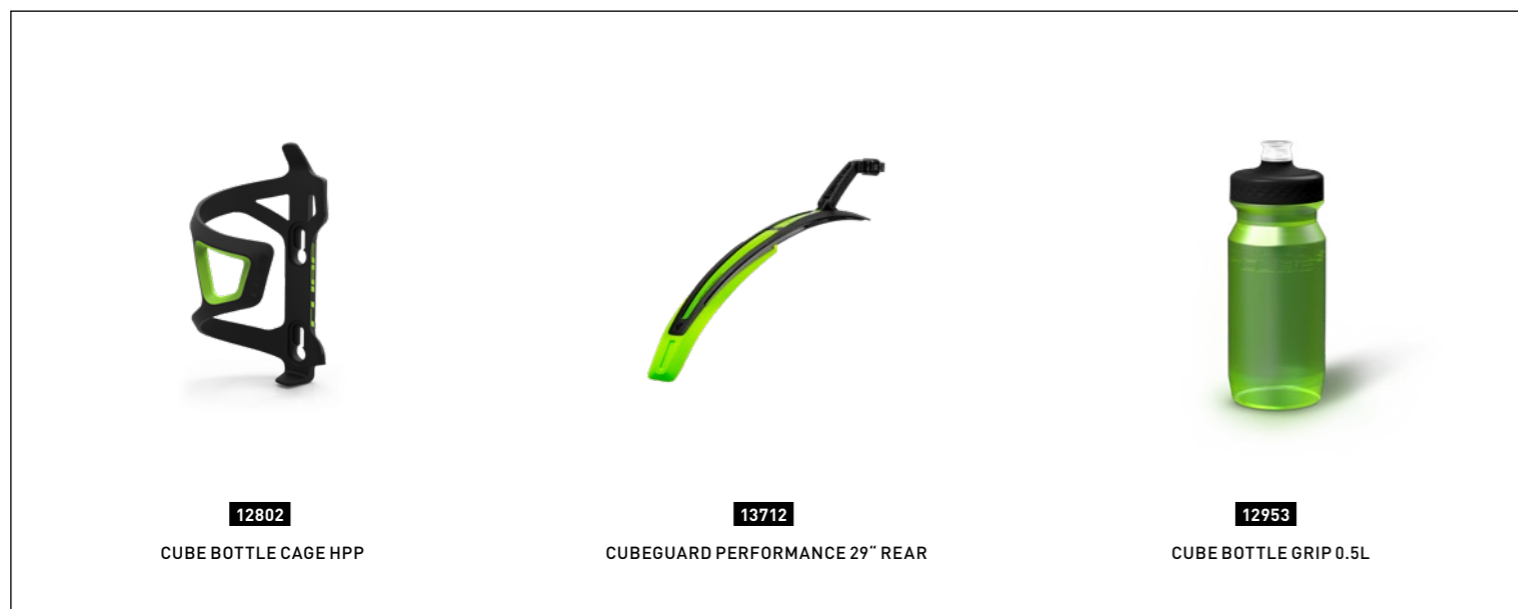
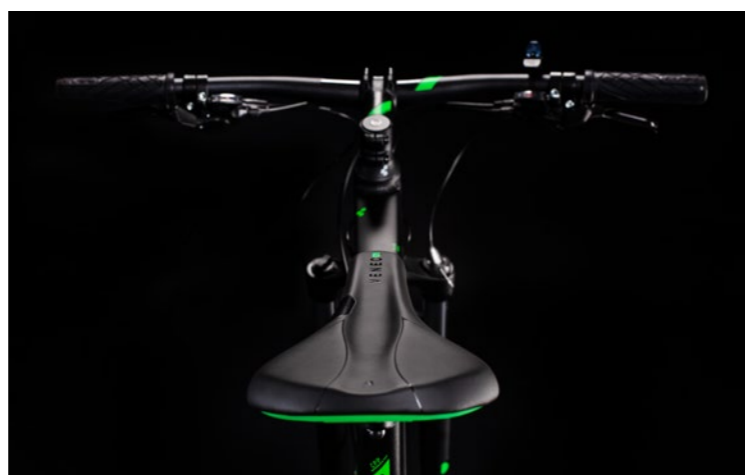

12802
CUBE BOTTLE CAGE HPP

13712
CUBEGUARD PERFORMANCE 29" REAR

12953
CUBE BOTTLE GRIP 0.5L

When your mountain biking ambitions begin to reach a little further afield, you'll need a bike that's up to the task. That's where the Aim Race comes in – a well-equipped, easy-to-handle and reliable trail companion that won't let you down, even as your skills and confidence grow. With our neat hidden rack and fender mounting points, it's also incredibly easy to convert into a weekday commuter or long-distance tourer. The light, strong and durable Aluminium Lite frame uses our Agile Ride Geometry for the ideal combination of stability and liveliness. We added a Suntour suspension fork with remote lockout to help smooth out the bumps, while powerful Shimano hydraulic disc brakes will give you the confidence to tackle even steep descents in perfect control. Internal cable routing means that the slick-shifting Shimano gears will stay that way with absolutely minimal maintenance, so you can concentrate on the ride, and it's all topped off with our versatile Size Split system for perfect sizing. What are you waiting for? Let's ride!

FRAME Aluminium Lite, AMF, Internal Cable Routing, Easy Mount Kickstand Ready
SIZE Size Split: 27.5: 14", 16", 18" // 29: 17", 19", 21", 23"
FORK Suntour XCM Disc, 100mm, Remote Lockout

HEADSET CUBE FPH863, Semi-Integrated
STEM CUBE Performance Stem, 31.8mm
HANDLEBAR CUBE Rise Trail Bar, 660mm
GRIPS CUBE Performance Grip
REAR DERAILLEUR Shimano RD-M360-SGS, 8-Speed
SHIFTERS Shimano SL-M315, Rapidfire-Plus
FRONT DERAILLEUR Shimano FD-M310, Top Swing, 31.8mm Clamp
BRAKE SYSTEM Shimano BR-MT200, Hydr. Disc Brake (160/160)
CRANKSET Shimano FC-TX801, 42x32x22T, 170mm
CASSETTE Shimano CS-HG318, 11-34T
CHAIN MC CU8.3
RIMS CUBE SD20, 32H, Disc
FRONT HUB Shimano HB-TX505, QR, Centerlock
REAR HUB Shimano FH-TX505, QR, Centerlock
TYRES Schwalbe Smart Sam, Active, 2.1
PEDALS CUBE PP MTB
SADDLE Natural Fit Venec Lite
SEAT POST CUBE Performance Post, 27.2mm
SEATCLAMP CUBE Varioclose, 31.8mm

WEIGHT 4,2 kg

SPARE PARTS#
10025 CUBE Disc Brake Pad Shimano Deore BR-M505/15/525/445/446
10148 CUBE Hanger #148 short version
10324 CUBE Headset Orbit Z
13543 Inner Tube 27,5"/29" MTB AGV 40 mm



Aspiring trail explorers, your search is over: The Aim Pro is the affordable, capable bike you need to fuel your burgeoning off-road passion. Combining a light, stiff and nimble-handling frame with a selection of easy-to-use, reliable components including Tektro hydraulic disc brakes and a comfortable suspension fork, it's the ideal choice for exploring further afield when you've run out of road. But just because it's affordable, that doesn't mean we've skimped on the details. From internal cable routing for clean looks and long-lasting smooth, reliable gear shifting with minimal maintenance to hidden rack and fender mounts for quick and easy upgrades, every detail is designed to make the Aim Pro an easy bike to live with. And, as you'd expect, our Size Split system makes it easy to find the right frame and wheel size combination to suit any rider. Let the adventures begin!

FRAME Aluminium Lite, AMF, Internal Cable Routing, Easy Mount Kickstand Ready
SIZE Size Split: 27.5: 14", 16", 18" // 29: 17", 19", 21", 23"
FORK R Suntour XCT Disc, 100mm, Remote Lockout

HEADSET CUBE FPH863, Semi-Integrated
STEM CUBE Performance Stem, 31.8mm
HANDLEBAR CUBE Rise Trail Bar, 680mm
GRIPS CUBE Performance Grip
REAR DERAILLEUR Shimano RD-M360-SGS, 8-Speed
SHIFTERS Shimano SL-M315, Rapidfire-Plus
FRONT DERAILLEUR Shimano FD-TY700, Downswing, 31.8mm Clamp
BRAKE SYSTEM Tektro HD-M275, Hydr. Disc Brake (160/160)
CRANKSET Shimano FC-TY501, 42x34x24T, 170mm
CASSETTE Shimano CS-HG200, 12-32T
CHAIN MC CUB.3
RIMS CUBE SD20, 32H, Disc
FRONT HUB CUBE Alloy Light, 6-Bolt
REAR HUB CUBE Alloy Light, 6-Bolt
TYRES Schwalbe Smart Sam, Active, 2.1
PEDALS CUBE PP MTB
SADDLE Natural Fit Venec Lite
SEAT POST CUBE Performance Post, 27.2mm
SEATCLAMP CUBE Varioclose, 31.8mm

WEIGHT 4,3 kg

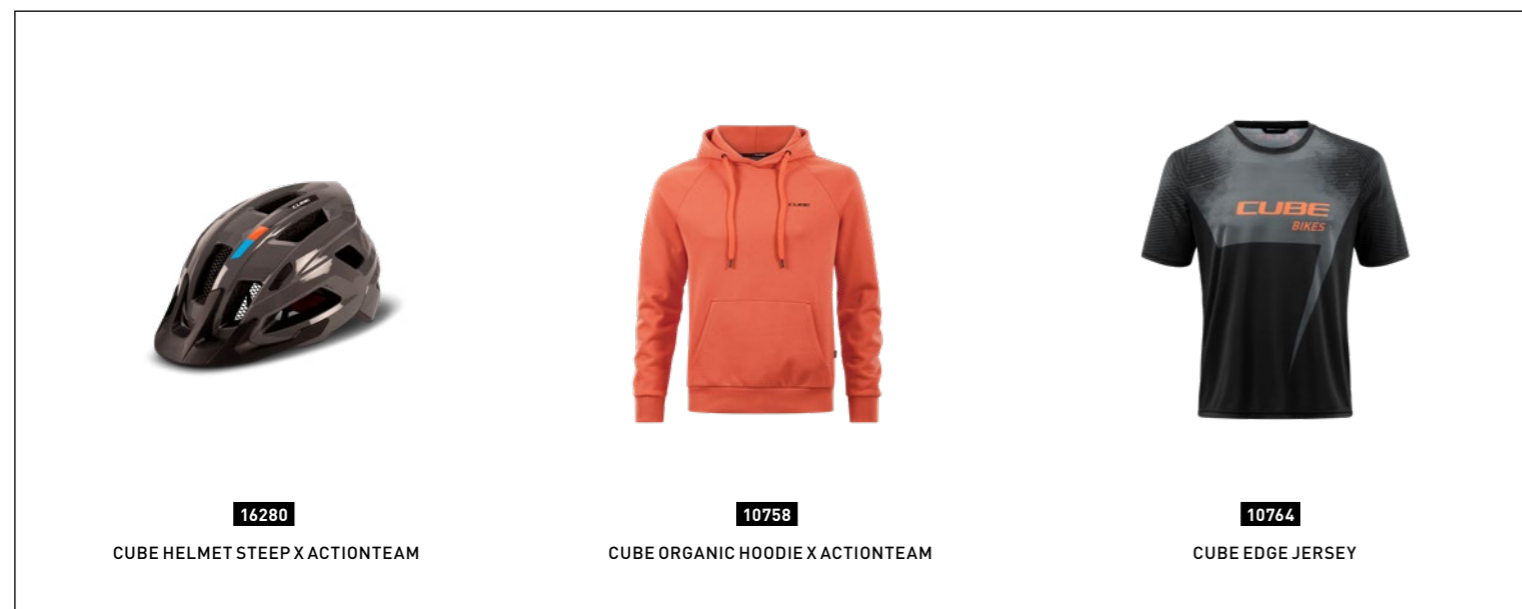

16280
CUBE HELMET STEEP X ACTIONTEAM

10758
CUBE ORGANIC HOODIE X ACTIONTEAM

10744
CUBE EDGE JERSEY

SPARE PARTS#
 10148 CUBE Hanger #148 short version
 10324 CUBE Headset Orbit Z
 13456 RFR Seatclamp with Quick Release 31,8 mm
 13543 Inner Tube 27,5"/29" MTB AGV 40 mm



If you're looking for one bike to do it all, we've got the ideal solution – the Aim Allroad. A fully equipped mountain bike with both off-road chops and street smarts, you can think of it as a two-wheeled SUV – a versatile all-rounder that'll slot so seamlessly into your life, you'll probably wonder how you managed without it. From weekend off-road adventures to the daily commute, its combination of mountain bike ruggedness and urban practicality is tough to beat. Clip-on mudguards, a built-in lighting system and CUBE kickstand make the ideal setup for city streets, while the Suntour suspension fork, wide-ranging Shimano gears and powerful Tektro mechanical disc brakes are all you need to keep riding when the Tarmac stops. Lightweight aluminium construction using our Advanced Mechanical Forming process results in a frame that's strong, light and tough – and, like all our frames, it's passed our stringent in-house testing with flying colours. It's even incredibly easy to add a luggage rack for commuting or those around town errands. All of which begs a simple question: is this bike the best of both worlds? We think it is. And, because it's available with our Size Split system, you're assured of finding the perfect fit.

FRAME Aluminium Lite, AMF, Internal Cable Routing, Easy Mount Kickstand Ready
SIZE Size Split: 27.5: 14", 16", 18" // 29: 17", 19", 21"
FORK Suntour XCE, 100mm

HEADSET CUBE FPH863, Semi-Integrated
STEM CUBE Performance Stem, 31.8mm
HANDLEBAR CUBE Rise Trail Bar, 680mm
GRIPS CUBE Performance Grip
REAR DERAILLEUR Shimano RD-TX800, 8-Speed
SHIFTERS Shimano ST-TX800, EZ Fire Plus
FRONT DERAILLEUR Shimano FD-TY700-TS6, Downswing, 31.8mm Clamp
BRAKE SYSTEM Tektro MD-280, Mech. Disc Brake
CRANKSET Shimano FC-TY501, 42x34x24T, 170mm
CASSETTE Shimano CS-HG200, 12-32T
CHAIN MC CU8.3
RIMS CUBE SD20, 32H, Disc
FRONT HUB Shimano DH-3D32 Hub Dynamo
REAR HUB Cube Alloy Light, 6-Bolt
TYRES Schwalbe Smart Sam, Active, 2.1
PEDALS CUBE PP MTB
SADDLE Natural Fit Venec Lite
SEAT POST CUBE Performance Post, 27.2mm
SEATCLAMP CUBE Varioclose, 31.8mm
FRONT LIGHT Büchel Country LED
REAR LIGHT relock Standlight
KICKSTAND CUBE Stand Cmpt
MUDGUARDS CID 60
BELL luvo

WEIGHT 5,9 kg

SPARE PARTS

- 10148** CUBE Hanger #148 short version
- 10324** CUBE Headset Orbit Z
- 13456** RFR Seatclamp with Quick Release 31,8 mm
- 13543** Inner Tube 27,5"/29" MTB AGV 40 mm



11046
CUBE ORGANIC LONGSLEEVE



93328
ACID BOTTLE CAGE HPP



11844
CUBE AFTER RACE HIGH CUT

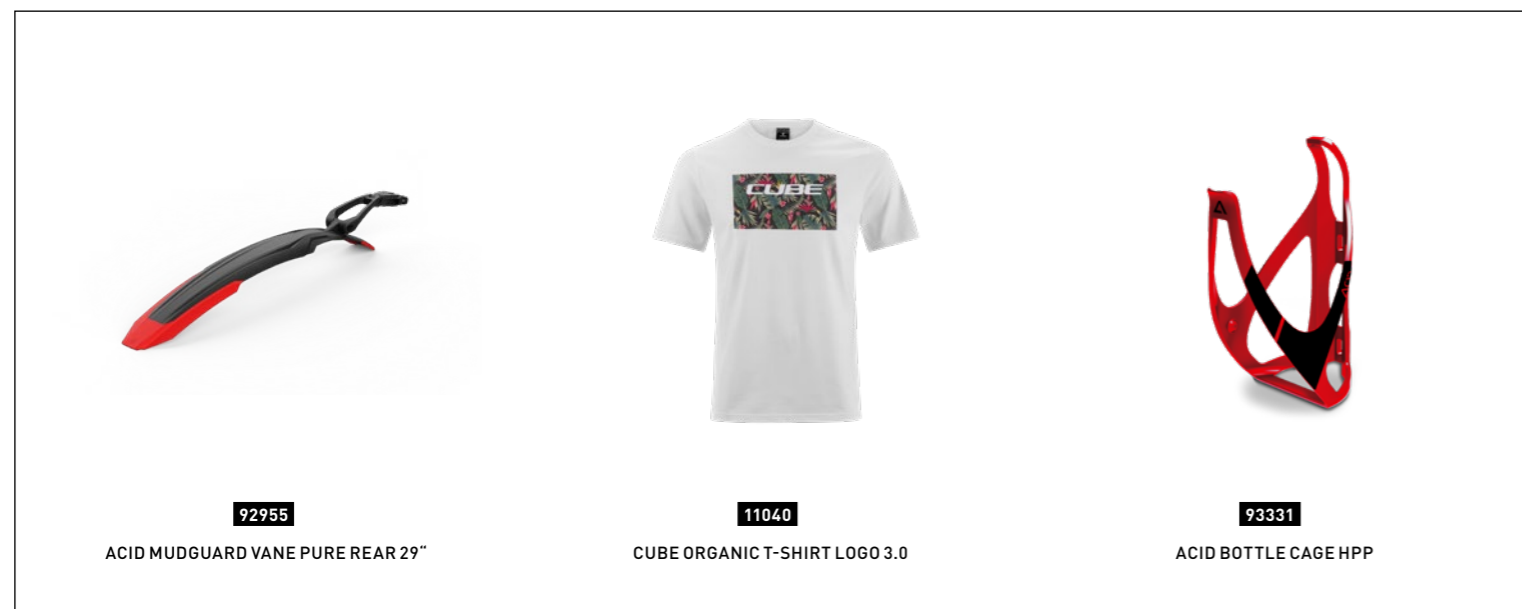
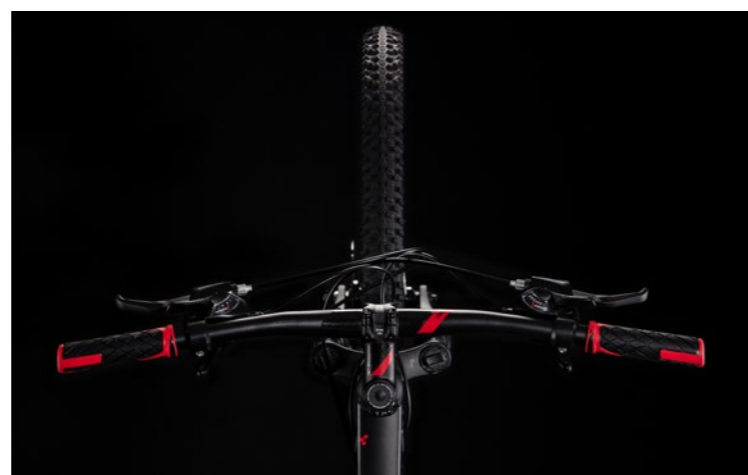

92955
ACID MUDGUARD VANE PURE REAR 29"

11040
CUBE ORGANIC T-SHIRT LOGO 3.0

93331
ACID BOTTLE CAGE HPP

If you're just starting out in the world of fat tyre adventuring, you'll need a bike you can rely on – a companion that'll be with you over every pebble, rock and root, no matter where your curiosity takes you. That's why we designed the Aim, using our expertise in aluminium frame building to create a bike that's perfectly suited to the job. You're assured a comfortable ride and safe, intuitive handling thanks to our Agile Ride Geometry and light, strong Aluminium Lite frame. Fitting fenders or a rack is quick and easy thanks to our cunningly hidden mounting system. Internal cable routing minimises maintenance and complements the Aim's clean looks and, of course, we selected reliable components to keep you riding rather than fiddling with adjustments. The Suntour fork adds comfort and control over the bumps, easy-shifting Shimano gears give you the confidence to tackle any hill with ease, and powerful Tektro mechanical disc brakes mean you're always in control. The result is a bike that'll inspire you to explore, wherever the trail leads you. And with our Size Split system, you're sure to find the Aim to fit you perfectly.

FRAME Aluminium Lite, AMF, Internal Cable Routing, Easy Mount Kickstand Ready
SIZE Size Split: 27.5: 14", 16", 18" // 29: 17", 19", 21"
FORK Suntour XCE, 100mm

HEADSET CUBE FPH863, Semi-Integrated
STEM CUBE Performance Stem, 31.8mm
HANDLEBAR CUBE Rise Trail Bar, 680mm
GRIPS CUBE Performance Grip
REAR DERAILLEUR Shimano RD-TX800, 8-Speed
SHIFTERS Shimano ST-TX800, EZ Fire Plus
FRONT DERAILLEUR Shimano FD-TY700-TS6, Downswing, 31.8mm Clamp
BRAKE SYSTEM Tektro MD-280, Mech. Disc Brake
CRANKSET Shimano FC-TY501, 42x34x24T, 170mm
CASSETTE Shimano CS-HG200, 12-32T
CHAIN MC CU8.3
RIMS CUBE SD20, 32H, Disc
FRONT HUB CUBE Alloy Light, 6-Bolt
REAR HUB CUBE Alloy Light, 6-Bolt
TYRES Schwalbe Smart Sam, Active, 2.1
PEDALS CUBE PP MTB
SADDLE Natural Fit Venec Lite
SEAT POST CUBE Performance Post, 27.2mm
SEATCLAMP CUBE Varioclose, 31.8mm

WEIGHT 4,5 kg

SPARE PARTS#
10148 CUBE Hanger #148 short version
10324 CUBE Headset Orbit Z
13456 RFR Seatclamp with Quick Release 31,8 mm
13543 Inner Tube 27,5"/29" MTB AGV 40 mm

FLYING CIRCUS

318300 petrol 'n' black

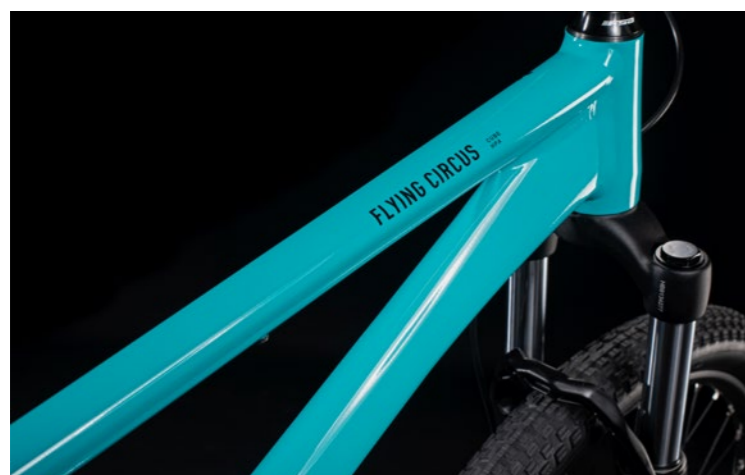

The Flying Circus is the rebirth of a CUBE legend – our dirt jump and pump track bike is back. With perfectly balanced geometry for aerial antics, it's not just a tough cookie but a good-looking one, too – designed with strength in mind but with an eye on aesthetics, too. Choose the top tube length that best suits your riding style, then use the super-short chain stays to manual to your heart's content. The dropouts are adjustable and we even fitted an integrated headset to reduce weight. With a Manitou Circus Comp fork, 28T BMX crank, Shimano hydraulic disc brakes and singlespeed setup, you've everything you need to perfect your steeze.

FRAME# Aluminium Lite, AMF, Tapered Headtube, BSA BB, Dirt Jump Optimized, Pumptrack Optimized, Adjustable Dropouts, Rear Derailleur Ready
SIZE# M, L
FORK# Manitou Circus Sport, 100mm

HEADSET# SA Orbit I-t, Integrated, Top 1 1/8", Bottom 1 1/2"
STEM# CUBE Performance Stem Pro, 31.8mm
HANDLEBAR# CUBE Rise Trail Bar Pro, 740mm
GRIPS# elo
BRAKE SYSTEM# Shimano BR-MT400, Hydr. Disc Brake (160/160)
CRANKSET# Samox BMX, 28T
CHAIN# MC Z1
RIMS# CUBE MD23, 32H, Disc, Tubeless Ready
FRONT HUB# CUBE TW1F, 20mm, 6-Bolt
REAR HUB# CUBE Mi-7R, Singlespeed, 6-Bolt
TYRES# Schwalbe Table Top, 2.25
SADDLE# DG Apollo RL
SEAT POST# CUBE Performance Post, 30.9mm
SEATCLAMP# CUBE Screwlock, 34.9mm

WEIGHT# 2,3 kg



17071
CUBE SHOES GTY MAZE CANVAS

16228
CUBE HELMET DIRT 2.0

93250
ACID PEDALS FLAT A1-CB

SPARE PARTS#
34189 Dropout Set QR complete incl. all screws and nuts



Go-anywhere freedom has a name: Nutrail. This is a bike that holds its line off-road no matter how steep, rocky, loose or slippery the surface. It keeps going where others have long since thrown in the towel, thanks to the extraordinary levels of grip and cushioning available from the 4.4in Schwalbe Jumbo Jim tyres. Born out of necessity when riders were looking for a solution to riding in snow or soft sand, the fatbike has come of age and extended its versatility way beyond those surfaces. It's the reason we equipped the Nutrail to take on anything, starting with the incredible range and easy, reliable shifting of Sram's SX Eagle 1x12 transmission, which gives you the ratios you need to tackle any trail, anywhere, anytime. Manitou's fatbike-specific Mastodon fork will hold your line come what may, and powerful Shimano MT400 hydraulic disc brakes give you complete control. As for the frame, it's a masterpiece of CUBE design detail. For example, the use of triple-butted and hydroformed High Performance Aluminium tubes allowed our engineering team to put extra material where it's needed for strength and rigidity, and carefully remove it where weight can safely be saved. The result is a fatbike that defies expectations for weight, while performing superbly. Riding is believing. Expand your horizons – ride Nutrail.

FRAME#HPA Superlite, Advanced Hydroforming, Triple Butted, ARG, Tapered Head Tube, Internal Cable Routing, PressFit BB
SIZE#5", 17", 19", 21"
FORK#Manitou Mastodon Comp, 100mm

HEADSET#SA Orbit 1.5B ZS-1, Semi-Integrated, Top 1 1/8" Bottom 1 1/2"
STEM#Newmen Evolution 318.4, 31.8mm
HANDLEBAR#Newmen Evolution 318.20, 760mm
GRIPS#CUBE Race Grip 31mm, 1-Clamp
REAR DERAILLEUR#Sram SX Eagle™, 12-Speed
SHIFTERS#Sram SX Eagle™ Trigger
BRAKE SYSTEM#Shimano BR-MT400, Hydr. Disc Brake (180/180)
CRANKSET#Sram X1 1000 Fat5 Eagle™ DUB, 30T, 175mm
CASSETTE#Sram PG-1210 Eagle™, 11-50T
CHAIN#Sram SX Eagle™
WHEELSET#nsner Fat Attack, 15x150mm/12x197mm
TYRES#schwalbe Jumbo Jim, Kevlar, 4.4
SADDLE#Natural Fit Venec Lite
SEAT POST#CUBE Dropper Post, Handlebar Lever, Internal Cable Routing, 30.9mm, 425x130mm
SEATCLAMP#CUBE Screwlock, 34.9mm

WEIGHT#5,5 kg

SPARE PARTS#
8651 CUBE HANGER_mtb-x12-std-2020 [18-05516]

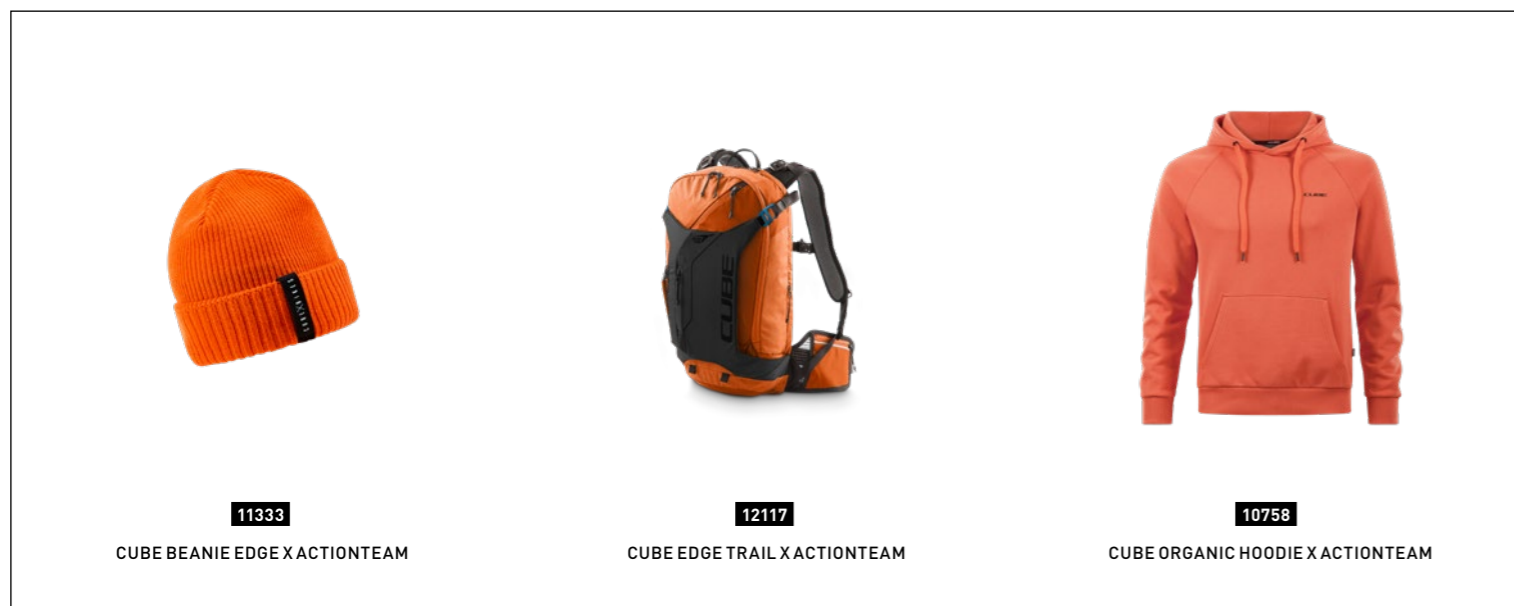

11333
 CUBE BEANIE EDGE X ACTIONTEAM

12117
 CUBE EDGE TRAIL X ACTIONTEAM

10758
 CUBE ORGANIC HOODIE X ACTIONTEAM

F U L L
S P S I O
U E O
S N N

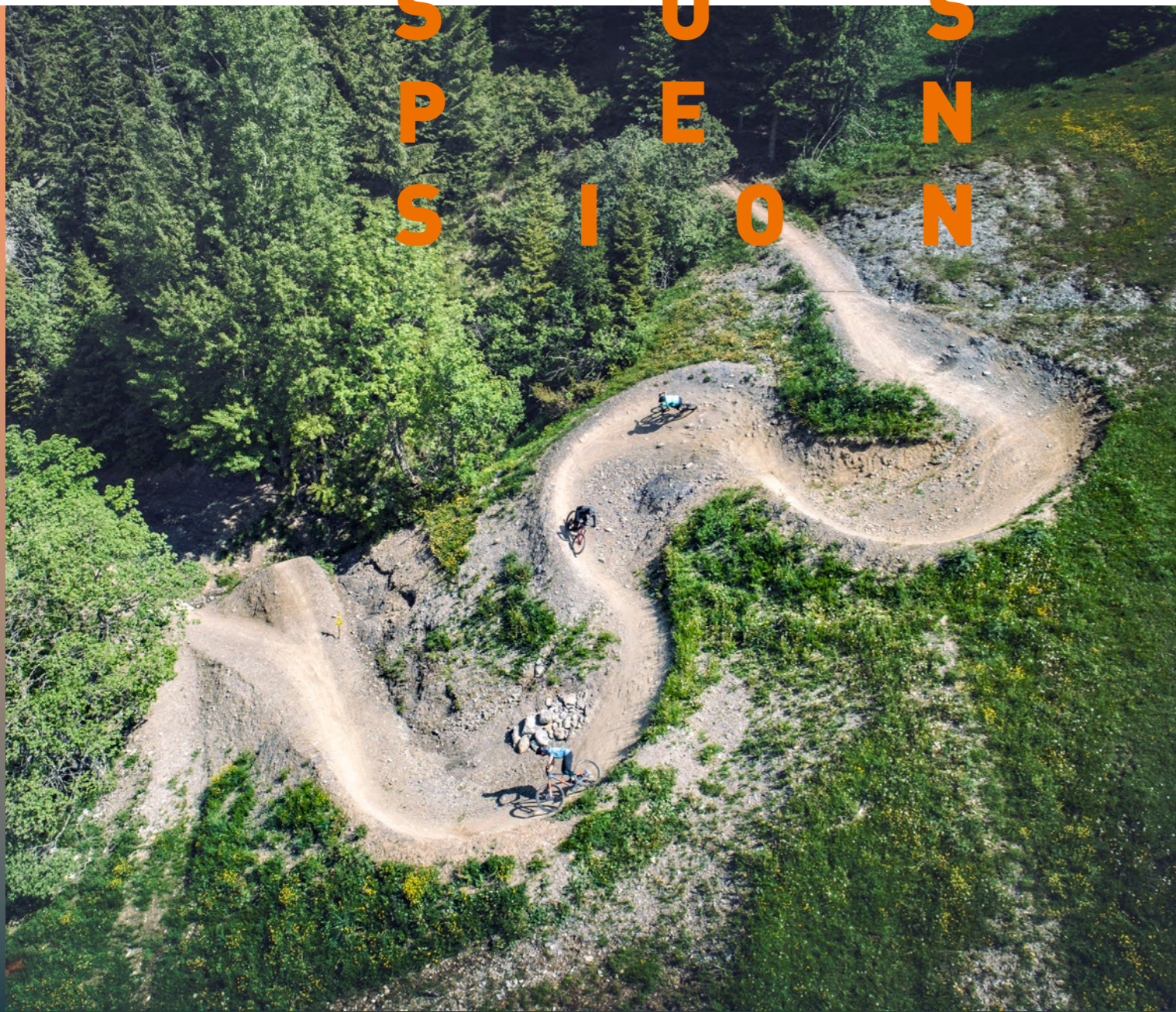

	CROSS COUNTRY	TOUR & TRAIL	ALL MOUNTAIN	ENDURO	GRAVITY
092 AMS 100 29	█	█			
102 STEREO 120 29		█	█		
112 STEREO 140 27.5			█	█	
120 STEREO 150 29			█	█	
130 STEREO 170 29				█	█
138 TWO15 27.5, 29					█



- 092 **AMS 100** | 29
- 102 **STEREO 120** | 29
- 112 **STEREO 140** | 27.5
- 120 **STEREO 150** | 29
- 130 **STEREO 170** | 29
- 138 **TWO15** | 27.5, 29

AMS 100

The most uncompromising race full susser ever built? Quite possibly. Our finest C:68 carbon, crafted into a chassis that's as ruthlessly efficient as it is light and elegant – and now with an added dose of trail-ready attitude courtesy of our tougher, shred-ready TM variant.

STEREO

Tame the trail, come out on top. Whatever your riding ambitions, there's a Stereo to match. From the ride-all-day comfort of the Stereo 120 to the mountain-crushing abilities of the brand new Stereo 170, our proven four-bar design will help you keep the rubber side down in style.

TWO15

Finishing second isn't an option. When the clock is running, the gradient is steep and the obstacles are boulder-sized, you need a bike that's designed to win. The Two15 has downhill racing in its DNA: light, agile and hard as nails, it's your gravity wingman.

FOR us #Racers

We've more than a decade and a half's experience making fast, light cross-country full-suspension bikes. Everything we've learnt during that time has gone into this frame. From the Boost 148 rear end and tapered head tube – which contribute to the AMS 100's superlative pedalling efficiency and uncannily accurate steering – to the superlight C:68 carbon construction and Advanced Twin Mold technology, everything about this frame serves one purpose: to make it the fastest way to get from A to B cross country. Stealth dropper post compatibility makes for a simple upgrade, internal cable routing keeps gear shifts clean even on the muddiest of race courses, and the super-clean appearance is given a helping hand by hiding bolts and pivots away.



FULL SUSPENSION



When you push yourself to perform at your absolute best in all your training and racing, it's only natural that you'll want a bike that meets your expectations. That's why we created the AMS 100 C:68 SLT 29 – to get you another few pedal revolutions closer to the podium. How? Simple: by starting with our proven four-bar suspension system and refining every detail. Our best C:68 carbon is finessed into the lightest, stiffest structure possible using our own Advanced Twin Mold manufacturing technique for the optimum blend of high strength, low weight and unbeatable durability. From the hidden pivots and sleek rocker design to the tapered head tube and Boost rear end, every aspect is honed to perfection. But a frame this good is only as good as the weakest component – so we selected only the very best. Sram's light, slick and precise XX1 wireless Eagle AXS 1x12 transmission transfers your power to the stiff, agile Newmen Advanced carbon wheelset. Sleek, featherweight Newmen carbon cockpit components keep you on track. And Kashima-coated Fox suspension ensures that every race course undulation is ironed out. If there's a faster, lighter, more efficient and more reliable cross-country race bike out there, we've yet to see it.

FRAME# C:68 Monocoque Advanced Twin Mold Technology, ARG, ERC, FSP 4-Link, Boost 148, AXH
SIZE# 6", 18", 20", 22"
FORK# Fox 32 Float SC FIT4 Factory, Tapered, 15x110mm, Kashima Coated, 100mm, 2-Position Remote Lever
SHOCK# Fox Float DPS Factory Remote EVOL, 165x38mm, 2-Position Remote Lever, Kashima Coated
SHOCK HARDWARE# Front: 30x8mm, Rear: 30x8mm

HEADSET# SA Orbit I-t, Integrated, Top 1 1/8", Bottom 1 1/2"
STEM# Newmen Evolution SL 318.2, 31.8mm
HANDLEBAR# Newmen Advanced SL 318.0, Carbon, 740mm
GRIPS# CUBE Race SL Grip 29.5mm, 1-Clamp
REAR DERAILLEUR# Sram XX1 Eagle AXS™, 12-Speed
SHIFTERS# Sram Eagle AXS™ Controlller
BRAKE SYSTEM# Sram Level Ultimate, Hydr. Disc Brake (160/160)
CRANKSET# Sram XX1 Eagle™ Carbon DUB 32T, 175mm (170mm for 16" frame size)
CASSETTE# Sram XG-1299 Rainbow, 10-50T
CHAIN# Sram PC-XX1 Eagle™ Rainbow
WHEELSET# Newmen Advanced SL X.25 Carbon, 28/28 Spokes, 15x110mm / 12x148mm, Tubeless Ready
FRONT TIRE# Schwalbe Racing Ray, Addix Speedgrip, Kevlar, 2.1, LiteSkin
REAR TIRE# Schwalbe Racing Ralph, Addix Speed, Kevlar, 2.1, LiteSkin
SADDLE# Natural Fit Nuance SLT Carbon
SEAT POST# Newmen Advanced SL, Carbon, 31.6mm
SEATCLAMP# CUBE Screwlock, 34.9mm

WEIGHT# 7 kg

SPARE PARTS#
8654 CUBE HANGER_mtb/rr-x12-std (18-06267)
10060 CUBE Disc Brake Pad SRAM Red22/Force22/Rival22/S700/Level
10339 CUBE Headset Orbit I-T + 1 1/8 crown race
10555 CUBE Shock Mount Set AMS from MY 2017 on
10556 CUBE Seat Stay to Link Set AMS MY 2017
10557 CUBE Rock Mount Set



17089
CUBE SHOES MTB C:62 SLT

11292
CUBE SLT JERSEY

11294
CUBE SLT BIB SHORTS



You know how it is. You've put the miles in over the winter, honed your training to perfection and marked off all the race weekends in the calendar. Now all you need is a bike that'll match your ambition – and that's where the AMS 100 C:68 SL 29 comes in. It's designed to perform in the toughest of race conditions, so that you can realise your true potential. Everything we've learnt over more than a decade and a half of building fast, light cross-country full-suspension bikes has gone into this frame. From the Boost 148 rear end and tapered head tube to the superlight C:68 carbon construction and Advanced Twin Mold technology, every feature is designed to help make this bike the fastest way to get from A to B cross country. The Fox Float DPS Performance Elite rear shock and Fox 32 Float Performance fork both feature remote lockout, whilst Newmen carbon cockpit components save vital grammes and ensure you're always in complete control. With Shimano XT hydraulic disc brakes and 12-speed transmission, you're assured of reliable forward propulsion and stopping in any and all weather conditions. The only thing missing from this race-winning machine... is you.

FRAME# C:68 Monocoque Advanced Twin Mold Technology, ARG, ERC, FSP 4-Link, Boost 148, AXH
SIZE# 6", 18", 20", 22"
FORK# Fox 32 Float SC, 2-Position Remote Lever, Tapered, 15x110mm, 100mm
SHOCK# Fox Float DPS Remote EVOL, 165x38mm, 2-Position Remote Lever
SHOCK HARDWARE# Front: 30x8mm, Rear: 30x8mm

HEADSET# SA Orbit I-t, Integrated, Top 1 1/8", Bottom 1 1/2"
STEM# Newmen Evolution SL 318.2, 31.8mm
HANDLEBAR# Newmen Advanced 318.0, Carbon, 740mm
GRIPS# CUBE Race SL Grip 29.5mm, 1-Clamp
REAR DERAILLEUR# Shimano XT RD-M8100-SGS, ShadowPlus, 12-Speed
SHIFTERS# Shimano SLX SL-M7100-I Direct Attach
BRAKE SYSTEM# Shimano XT BR-M8100, Hydr. Disc Brake (180/160)
CRANKSET# Shimano XT FC-M8100, Boost, 32T, 175mm (170mm for 16" frame size)
CASSETTE# Shimano SLX CS-M7100, 10-51T
CHAIN# Shimano CN-M7100
WHEELSET# Newmen Evolution SL X.A.25, 28/28 Spokes, 15x110mm / 12x148mm, Tubeless Ready
FRONT TIRE# Schwalbe Racing Ray, Addix Speedgrip, Kevlar, 2.25, LiteSkin
REAR TIRE# Schwalbe Racing Ralph, Addix Speed, Kevlar, 2.25, LiteSkin
SADDLE# Natural Fit Nuance SLT MTB
SEAT POST# Newmen Advanced, Carbon, 31.6mm
SEATCLAMP# CUBE Screwlock, 34.9mm

WEIGHT# 0,9 kg

SPARE PARTS#
8654 CUBE HANGER_mtb/rr-x12-std (18-06267)
10339 CUBE Headset Orbit I-T + 1 1/8 crown race
10555 CUBE Shock Mount Set AMS from MY 2017 on
10556 CUBE Seat Stay to Link Set AMS MY 2017
10557 CUBE Rock Mount Set



10941
CUBE TEAMLINE JERSEY



11838
CUBE HIGH CUT



10942
CUBE TEAMLINE BIB SHORTS



At CUBE we're great believers in the adage that you shouldn't always judge a book by its cover. That's why, with the AMS 100 C:68™ 29, we've combined the race-ready speed of our AMS 100 platform with trail-tough components like a 120mm travel Fox 34 Float Factory fork, Fox Transfer Factory remote dropper post and wider-profile Newmen Evolution rims shod with grippy, big-volume 2.35in tyres. The result is a bike that doesn't just look fast, but is capable of taking even the most demanding of trails – or race courses – apart and reassembling them in smooth, easily digestible chunks of flat-out fun. Add Sram's stunning Eagle 1x12 drivetrain and powerful Shimano XT hydraulic disc brakes, and you've got a trail-devouring machine that's tough to beat. The low weight, incredible stiffness and efficient kinematics of the AMS 100 chassis are a key part of this bike's stunning performance. Using the proven potential of our four-bar linkage suspension and packaging it around our proprietary C:68 carbon construction, our designers have succeeded in combining low weight, ground-hugging comfort and control, and incredible rigidity for accurate steering and on-demand acceleration. From the tapered steerer to the Boost rear end and elegant rocker, it's a bike that delivers on the promise of its looks. Carbon-framed efficiency, race course-bred speed and trail-capable components: it's the CUBE Trail Motion creed.

FRAME# C:68 Monocoque Advanced Twin Mold Technology, ARG, ERC, FSP 4-Link, Boost 148, AXH
SIZE# 6", 18", 20", 22"
FORK# Fox 34 Float SC FIT4 Factory, Tapered, 15x110mm, 120mm, Kashima Coated
SHOCK# Fox Float DPS Factory EVOL, 165x38mm, Kashima Coated
SHOCK HARDWARE# Front: 30x8mm, Rear: 30x8mm

HEADSET# SA Orbit I-t, Integrated, Top 1 1/8", Bottom 1 1/2"
STEM# Newmen Evolution 318.4, 31.8mm
HANDLEBAR# Newmen Advanced 318.20, Carbon, 750mm
GRIPS# DG Slater
REAR DERAILLEUR# Sram GX Eagle™, 12-Speed
SHIFTERS# Sram GX Eagle™ Trigger
BRAKE SYSTEM# Shimano XT BR-M8120/M8100, Hydr. Disc Brake (180/180)
CRANKSET# Sram X1 Eagle™ Carbon Boost DUB, 30T, 175mm (170mm for 16" frame size)
CASSETTE# Sram XG-1275, 10-50T
CHAIN# Sram SX Eagle™
WHEELSET# Newmen Evolution SL A.30, 28/28 Spokes, 15x110mm / 12x148mm, Tubeless Ready
TYRES# Schwalbe Nobby Nic, Addix Speedgrip, Kevlar, Tubeless Easy, 2.35
SADDLE# DG Radar
SEAT POST# Fox Transfer Factory 31.6mm, Kashima coated, 457x150mm (406x125mm for smallest frame size)
SEATCLAMP# CUBE Screwlock, 34.9mm

WEIGHT# 1,9 kg

SPARE PARTS#
8654 CUBE HANGER_mtb/tr-x12-std (18-06267)
10339 CUBE Headset Orbit I-T + 1 1/8 crown race
10555 CUBE Shock Mount Set AMS from MY 2017 on
10556 CUBE Seat Stay to Link Set AMS MY 2017
10557 CUBE Rock Mount Set

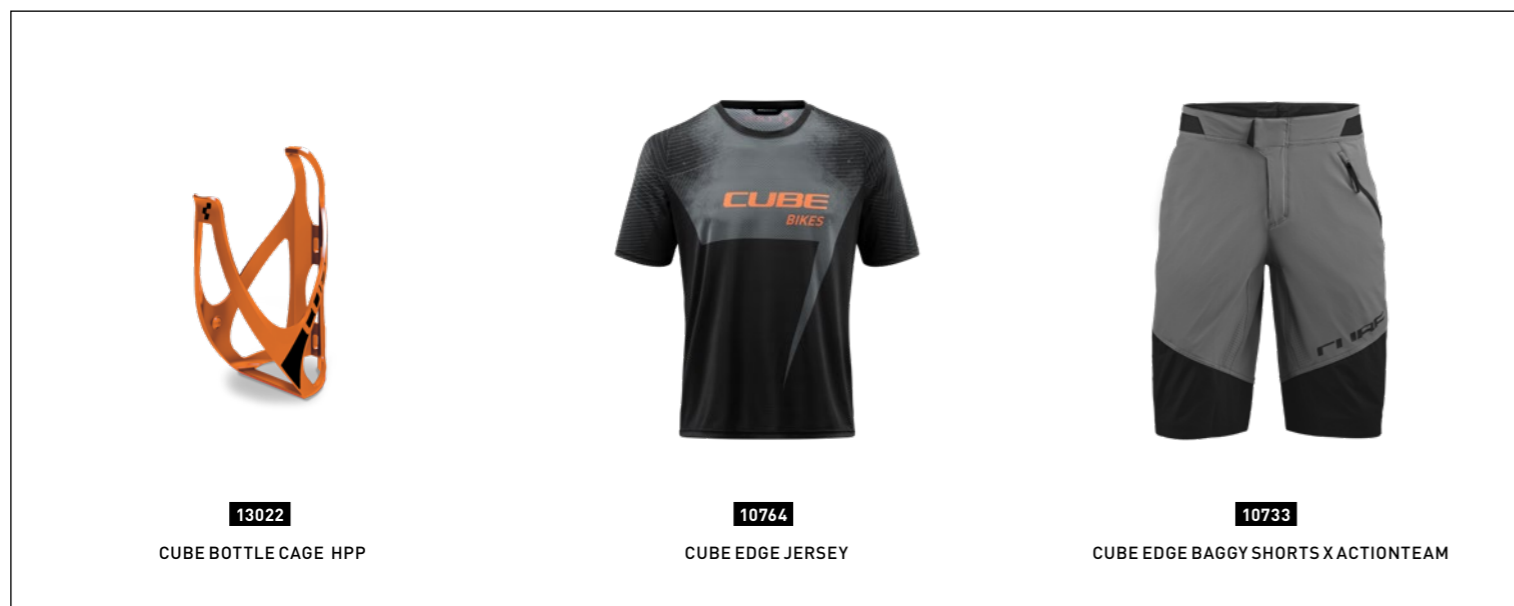

13022
CUBE BOTTLE CAGE HPP

10764
CUBE EDGE JERSEY

10733
CUBE EDGE BAGGY SHORTS X ACTIONTEAM

AMS 100 C:68 RACE 29

352100 carbon'n'grey



11010

CUBE BLACKLINE JERSEY



17047

CUBE SHOES MTB PEAK PRO



11014

CUBE BLACKLINE BAGGY SHORTS

Our top-flight cross-country race machine resets the bar for riders seeking the fastest, stiffest and lightest bike to help them achieve their race goals. Building on the proven efficiency of our well-established four-bar suspension platform, our engineers designed the AMS 100 C:68 Race 29's chassis around our proprietary C:68 featherweight carbon technology. Advanced Twin Mold technology allowed them to create a fast trail bike that blends low weight, ground-hugging control and supreme efficiency. But we didn't stop there. RockShox suspension technology – with a Boost rear end, tapered steerer and thru-axle fork – keeps both wheels glued to the trail for the ultimate in forward propulsion and steering accuracy, with a full 120mm of travel up front. Newmen cockpit components and a CUBE 130mm dropper post make tackling tricky trail obstacles a breeze, while Shimano's 12-speed transmission and hydraulic disc brakes – with 4-piston front calliper – deliver precise power exactly when you need it. Big-volume Schwalbe tyres on a Fulcrum Red 55 wheelset round off the package. Add it all up and it's everything the you could wish for in a bike built to get from A to B via the most fun trails, as fast as possible.



FRAME# C:68 Monocoque Advanced Twin Mold Technology, ARG, ERC, FSP 4-Link, Boost 148, AXH
SIZE# 6", 18", 20", 22"
FORK# RockShox Sektor RL Air, 15x110mm, Tapered, 120mm
SHOCK# RockShox Monarch RL, 165x38mm
SHOCK HARDWARE# Front: 30x8mm, Rear: 30x8mm



HEADSET# SA Orbit I-t, Integrated, Top 1 1/8", Bottom 1 1/2"
STEM# Newmen Evolution 318.4, 31.8mm
HANDLEBAR# Newmen Evolution 318.20, 760mm
GRIPS# CUBE Race SL Grip 29.5mm, 1-Clamp
REAR DERAILLEUR# Shimano XT RD-M8100-SGS, ShadowPlus, 12-Speed
SHIFTERS# Shimano SLX SL-M7100
BRAKE SYSTEM# Shimano BR-MT520/MT500, Hydr. Disc Brake (180/180)
CRANKSET# Shimano FC-MT610, Boost, 30T, 175mm (170mm for 16" frame size)
CASSETTE# Shimano SLX CS-M7100, 10-51T
CHAIN# Shimano CN-M7100
WHEELSET# Fulcrum Red 55, 28/28 Spokes, 15x110mm / 12x148mm, 622x23C, Tubeless Ready
TYRES# Schwalbe Nobby Nic, Addix Performance, Kevlar, 2,35
SADDLE# Natural Fit Nuance Lite
SEAT POST# CUBE Dropper Post, Handlebar Lever, Internal Cable Routing, 31.6mm, 425x130mm (403x120mm for smallest frame size)
SEATCLAMP# CUBE Screwlock, 34.9mm



WEIGHT# 2,6 kg



SPARE PARTS#
8654 CUBE HANGER_mtb/tr-x12-std (18-06267)
10339 CUBE Headset Orbit I-T + 1 1/8 crown race
10555 CUBE Shock Mount Set AMS from MY 2017 on
10556 CUBE Seat Stay to Link Set AMS MY 2017
10557 CUBE Rock Mount Set

FULL SUSPENSION

FOR us #Pathfinders

In many ways the Stereo 120 is the full suspension bike that kick-started our reputation for building comfortable, high-performance trail bikes. New for 2020, we've added a carbon main triangle for even lower weight – so you can enjoy your trail time more. Years of experience in carbon frame construction means that our engineers know exactly where to add material for strength, and where they can remove it to save weight – all backed by the reassurance of our extensive in-house testing. The rest of the frame is pure Stereo 120 goodness, featuring the short rocker, covered pivot bearings and efficient kinematics of its predecessors for superb traction, comfort and control. The tapered head tube and Boost rear axle ensure great handling and steering precision, and big 29er wheels roll easily. Ride where your curiosity takes you...





Proving that you should never judge a book by its cover, the Stereo 120 SLT 29's understated looks disguise its prodigious trail-taming abilities. And now we've improved it even more, by equipping it with a brand-new carbon main frame for even lower weight and exceptional efficiency, without sacrificing the comfort and reliability for which this bike is known. Internal cable routing, hidden rocker pivots and our proven Efficient Trail Control kinematics combined with Agile Trail Geometry all add up to a bike that is, in many ways, a wolf in sheep's clothing. From the slick, sleek and reliable Shimano XT brakes and 1x12 transmission to the Fox 34 Factory fork and DPS Factory shock – both with Kashima coatings for the ultimate in bump sensitivity – we've selected only the best parts to pair with our design team's latest masterpiece. A Fox Transfer Factory remote dropper post for those tricky, technical descents and a light, stiff e*thirteen carbon crankset with Newmen Evolution wheels complete the setup. Whether you like to ride multi-day adventures or just enjoy exploring singletrack on your home turf, the Stereo 120 SLT 29 has got your back.

FRAME#HPC Carbon Monocoque Advanced Twin Mold Technology, Aluminum 6061 T6 Rear Triangle, ATG, ETC 4-Link, Boost 148, AXH
SIZE#6", 18", 20", 22"
FORK#ox 34 Float Factory FIT4, Open(Adjustable)/Medium/Firm Mode, Tapered, 15x110mm, 130mm, Kashima Coated
SHOCK#ox Float DPS Factory EVOL, 190x45mm, Open(Adjustable)/Medium/Firm Mode, Kashima Coated
SHOCK HARDWARE#op: 40x8mm, Bottom: 22x8mm

HEADSET#SA Orbit I-t, Integrated, Top 1 1/8", Bottom 1 1/2"
STEM#Newmen Evolution 318.4, 31.8mm
HANDLEBAR#Newmen Advanced SL 318.20, Carbon, 750mm
GRIPS#CUBE Race SL Grip 29.5mm, 1-Clamp
REAR DERAILLEUR#Shimano XT RD-M8100-SGS, ShadowPlus, 12-Speed
SHIFTERS#Shimano XT SL-M8100-IR, Direct Attach
BRAKE SYSTEM#Shimano XT BR-M8100, Hydr. Disc Brake (180/180)
CRANKSET#*thirteen TRS Race Carbon, 30T, Boost, 175mm (170mm for 16" frame size)
CASSETTE#Shimano XT CS-M8100, 10-51T
CHAIN#Shimano CN-M8100
WHEELSET#Newmen Evolution SL X.A.25, 28/28 Spokes, 15x110mm / 12x148mm, Tubeless Ready
TYRES#Schwalbe Nobby Nic, Addix Speedgrip, Kevlar, Tubeless Easy, 2.35
SADDLE#Natural Fit Nuance SLT Carbon
SEAT POST#ox Transfer Factory 31.6mm, Kashima coated, 457x150mm (406x125mm for smallest frame size)
SEATCLAMP#CUBE Screwlock, 34.9mm

WEIGHT#1.9 kg

SPARE PARTS#
8510 CUBE Horstlink Set [19_FSV-120-29]
8511 CUBE Horstlink Set [19_FSV-120-29]
8514 CUBE Main Pivot Set [19_FSV-120-29]
8517 CUBE Rock Mount Set [19_FSV-120-29]
8523 CUBE Link to Shock [19_FSV-120-29]
8654 CUBE HANGER_mtb/rr-x12-std [18-06267]
10339 CUBE Headset Orbit I-T + 1 1/8 crown race

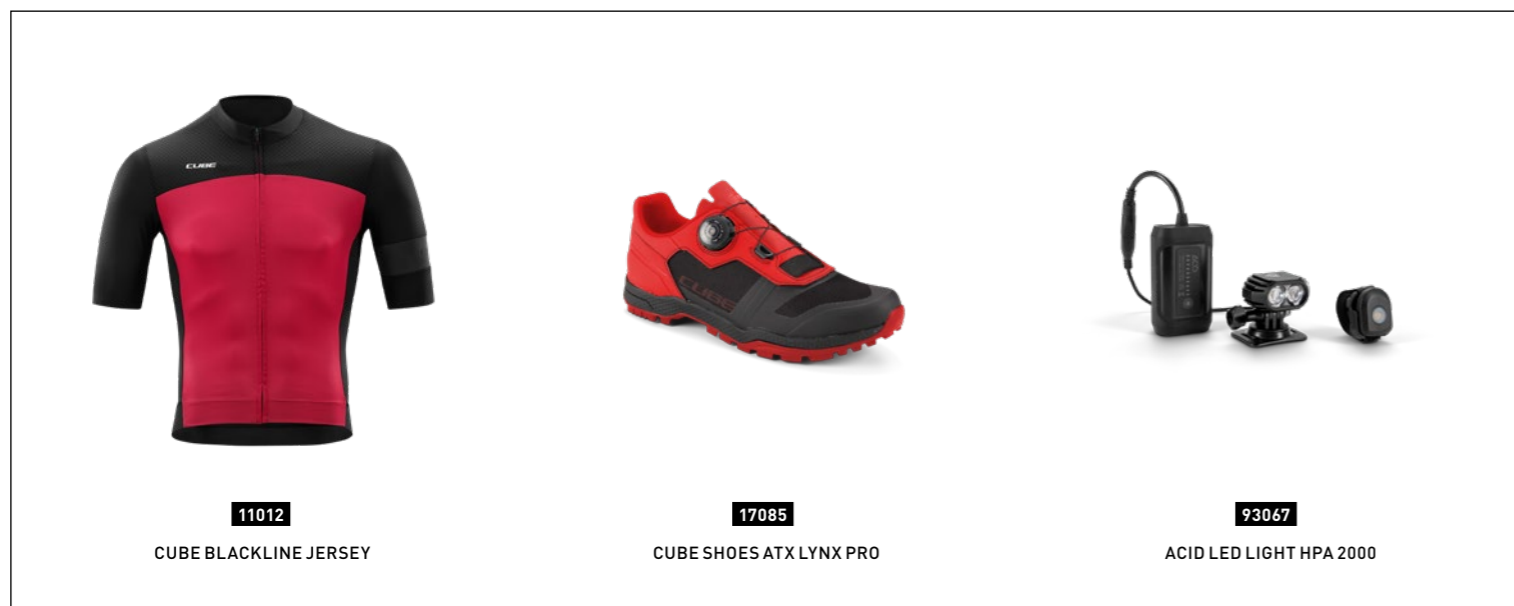

11012
CUBE BLACKLINE JERSEY



17085
CUBE SHOES ATX LYNX PRO



93067
ACID LED LIGHT HPA 2000

STEREO 120 HPC TM 29

353300 grey'n'orange



Our Trail Motion bikes are all about more control, more comfort and more fun. For the Stereo 120 HPC TM 29 we've built a completely new carbon main frame, incorporating all the features that make our Stereo 120 so popular – Agile Trail Geometry, covered rocker pivots, sleek lines and assured handling – in a new, lighter and stiffer format. But we didn't stop there. We also equipped it with everything you need to dissect the most demanding of singletrack trails with ease, time after time. The combination of sure-footed handling, easy-rolling 29er wheels, low weight and reliable components translates into endless off-road miles with maximum riding smiles. A Fox 34 Rhythm fork and matching Fox Float shock work together to seamlessly dispatch whatever obstacles lie in your path, while the Fulcrum wheelset and Sram 1x12 Eagle drivetrain translate your pedal power into forward motion via the grippy, comfortable Schwalbe tyres. We're aware, of course, that power is nothing without control – which is why we selected Shimano's powerful XT hydraulic disc brakes with a four-piston front calliper. And, because this bike is likely to inspire you to ride lines you thought you wouldn't be able to, there's a dropper post for extra confidence on those steep descents. It all adds up to a capable trail all-rounder that's simply inspirational, whether you're using it to show your riding buddies a rapidly disappearing view of your back or simply exploring new trails. Go further, take back control – ride the Stereo 120 HPC TM 29.

FRAME#HPC Carbon Monocoque Advanced Twin Mold Technology, Aluminum 6061 T6 Rear Triangle, ATG, ETC 4-Link, Boost 148, AXH
SIZE#6", 18", 20", 22"
FORK#Fox 34 Rhythm, 2-Position Sweep-Adjust GRIP Damper, Tapered, 15x110mm, 130mm
SHOCK#Fox Float DPS EVOL, 190x45mm, Open/Medium/Firm Mode
SHOCK HARDWARE#top: 40x8mm, Bottom: 22x8mm

HEADSET#SA Orbit I-t, Integrated, Top 1 1/8", Bottom 1 1/2"
STEM#Newmen Evolution 318.4, 31.8mm
HANDLEBAR#Newmen Evolution 318.20, 760mm
GRIPS#DG Slater
REAR DERAILLEUR#Sram GX Eagle™, 12-Speed
SHIFTERS#Sram NX Eagle™ Trigger
BRAKE SYSTEM#Shimano XT BR-M8120/M8100, Hydr. Disc Brake (203/180)
CRANKSET#Sram X1 1000 Eagle™ DUB 30T, Boost, 175mm
CASSETTE#Sram XG-1275, 10-50T
CHAIN#Sram SX Eagle™
WHEELSET#Fulcrum Red 55 EM, 28/28 Spokes, 15x110mm / 12x148mm, Tubeless Ready
TYRES#Schwalbe Nobby Nic, Addix Speedgrip, Kevlar, Tubeless Easy, 2.35
SADDLE#DG Radar
SEAT POST#CUBE Dropper Post, Handlebar Lever, Internal Cable Routing, 31.6mm, 480x150mm (420x125mm for smallest frame size)
SEATCLAMP#CUBE Screwlock, 34.9mm

WEIGHT#2.9 kg

SPARE PARTS#
8510 CUBE Horstlink Set [19_FSV-120-29]
8511 CUBE Horstlink Set [19_FSV-120-29]
8514 CUBE Main Pivot Set [19_FSV-120-29]
8517 CUBE Rock Mount Set [19_FSV-120-29]
8523 CUBE Link to Shock [19_FSV-120-29]
8654 CUBE HANGER_mtb/rr-x12-std [18-06267]
10339 CUBE Headset Orbit I-T + 1 1/8 crown race



10774

CUBE EDGE JERSEY



10733

CUBE EDGE BAGGY SHORTS X ACTIONTEAM



17072

CUBE SHOES MTB PEAK



STEREO 120 RACE 29

353200 lightgrey 'n' flashyellow

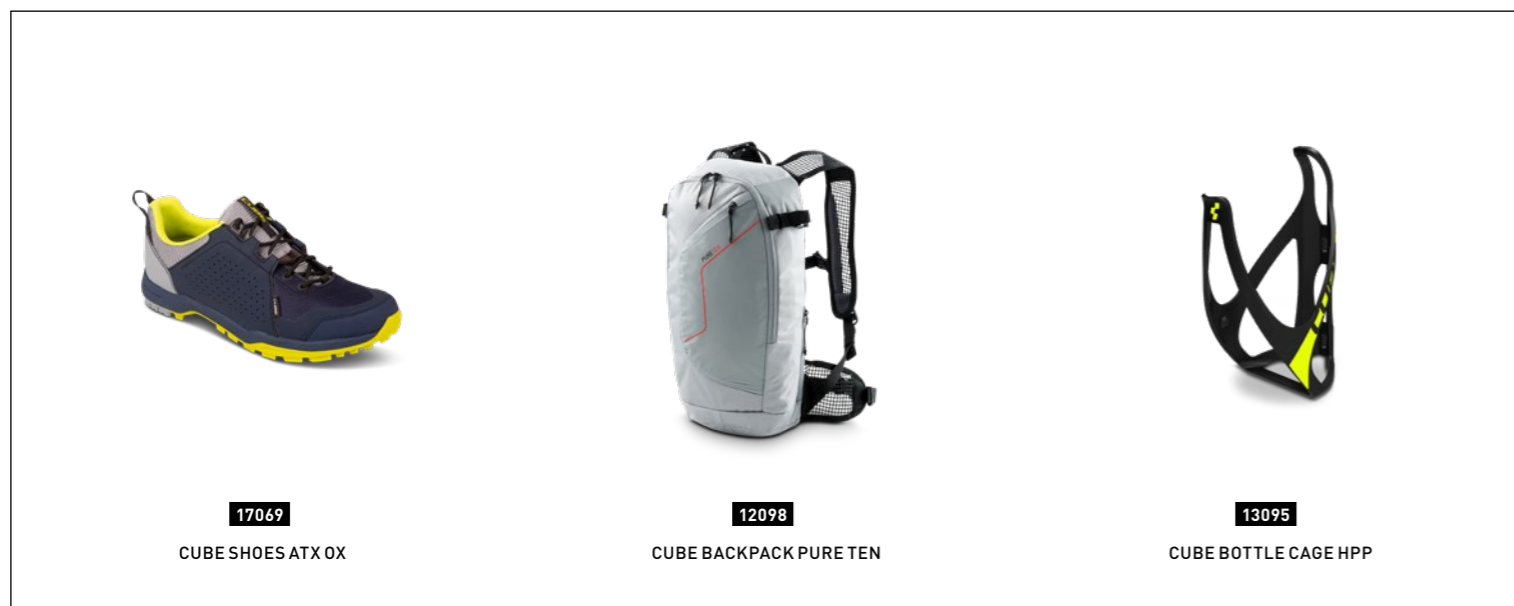

17069
CUBE SHOES ATX OX



12098
CUBE BACKPACK PURE TEN



13095
CUBE BOTTLE CAGE HPP

The Stereo 120 Race 29 is all about class-leading trail performance and comfort. From the sleek, hydroformed frame to the carefully selected components, we've sweated all the details to create a comfortable, versatile trail companion that'll inspire and entertain in equal measure. The RockShox Sektor RL fork serves up 130mm of smooth, easily adjustable bump-swallowing travel in tandem with a RockShox Deluxe Select+ rear shock, which adds 120mm of rear wheel travel. Wide Fulcrum Red 55 rims shod with grippy Schwalbe Nobby Nic tyres keep the rear end driving forward and the front end pointed where you want it to be, no matter what the trail serves up. And, of course, Shimano's super-slick and wide-ranging 1x12 transmission puts every climb within your reach, while powerful hydraulic disc brakes ensure you can always stop in good time. We even included a CUBE dropper post, so you can ride those steep, rocky and rooty trails with complete confidence. And details like the internal cable routing and hidden pivot bolts help keep everything working smoother for longer, so you can just ride. It all adds up to a finely balanced, easy-to-live-with, trail-taming companion, whether you're an ardent singletrack explorer or a multi-day endurance rider.



FRAME#IPA Advanced Hydroform, ATG, ETC 4-Link, AXH
SIZE#6", 18", 20", 22"
FORK#RockShox Sektor RL Air, 15x110mm, Tapered, 130mm
SHOCK#RockShox Deluxe Select+, 190x45mm, Rebound Adjust, Lockout
SHOCK HARDWARE#op: 40x8mm, Bottom: 22x8mm



HEADSET#SA 1.5E ZS, Tapered, Top Zero-Stack 1 1/8" (OD 44mm), Bottom Zero-Stack 1 1/2" (OD 56mm)
STEM#Newmen Evolution 318.4, 31.8mm
HANDLEBAR#Newmen Evolution 318.20, 760mm
GRIPS#CUBE Race SL Grip 29.5mm, 1-Clamp
REAR DERAILLEUR#Shimano XT RD-M8100-SGS, ShadowPlus, 12-Speed
SHIFTERS#Shimano SLX SL-M7100
BRAKE SYSTEM#Shimano BR-MT500, Hydr. Disc Brake (180/180)
CRANKSET#Shimano FC-MT610, Boost, 30T, 175mm (170mm for 16" frame size)
CASSETTE#Shimano SLX CS-M7100, 10-51T
CHAIN#Shimano CN-M7100
WHEELSET#Fulcrum Red 55, 15x110mm / 12x148mm, Tubeless Ready
TYRES#Schwalbe Nobby Nic, Addix Performance, Kevlar, 2.35
SADDLE#Natural Fit Venec
SEAT POST#CUBE Dropper Post, Handlebar Lever, Internal Cable Routing, 31.6mm, 425x130mm (403x120mm for smallest frame size)
SEATCLAMP#CUBE Screwlock, 34.9mm



WEIGHT#3.9 kg



SPARE PARTS#

- 8510** CUBE Horstlink Set (19_FSV-120-29)
- 8514** CUBE Main Pivot Set (19_FSV-120-29)
- 8517** CUBE Rock Mount Set (19_FSV-120-29)
- 8523** CUBE Link to Shock (19_FSV-120-29)
- 8654** CUBE HANGER_mtb/rr-x12-std (18-06267)
- 10025** CUBE Disc Brake Pad Shimano Deore BR-M505/15/525/445/446
- 10338** CUBE Headset Orbit 1.5E ZS 1 1/8 / 1.5 semi + 1 1/8 crown race

STEREO 120 PRO 29

353100 black 'n' blue

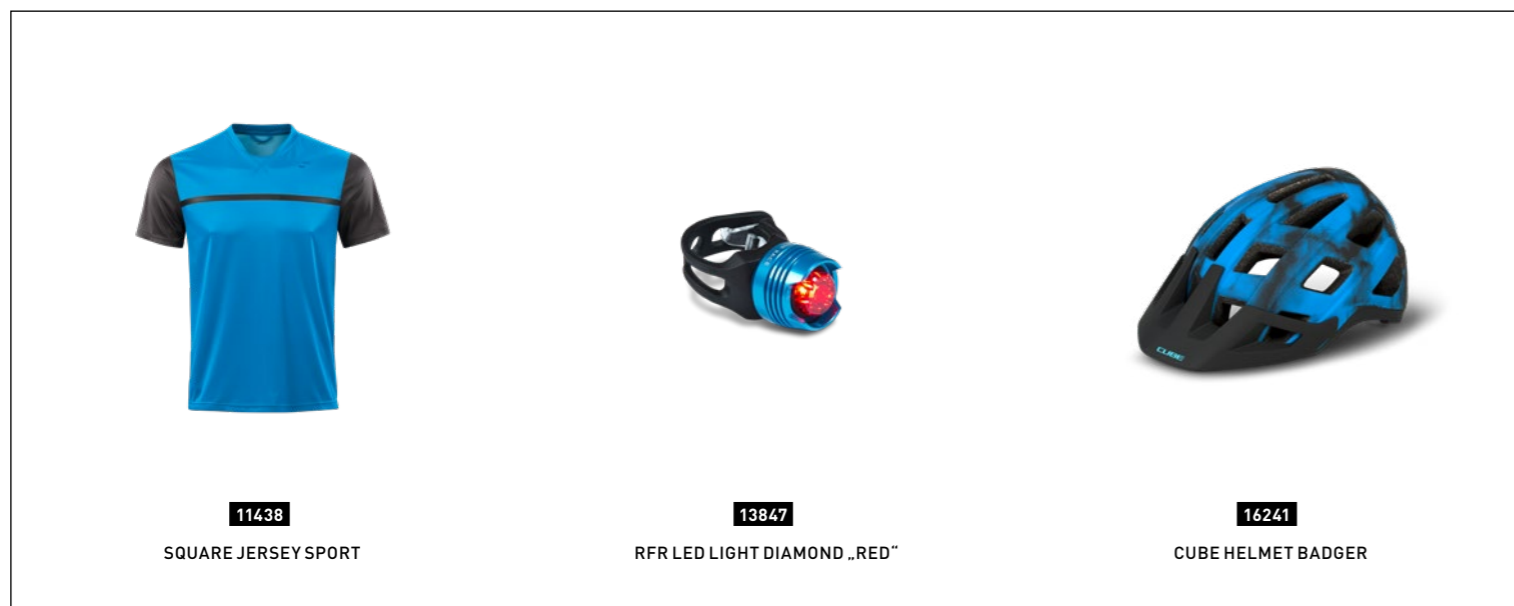

11438
SQUARE JERSEY SPORT



13847
RFR LED LIGHT DIAMOND „RED“



14241
CUBE HELMET BADGER



The Stereo 120 Pro 29 sets a new standard for comfort, control and agility on the trail. Smooth-rolling 29er wheels, Agile Trail Geometry and a sleek frame design make taming any trail a pleasure, wherever your weekend adventures take you. Triple-butted aluminium tubes – carefully shaped to combine low weight with superb strength – are honed into a chassis that's as good to look at as it is to ride, and we've chosen reliable, durable components and incorporated features like internal cable routing, so that you can concentrate on the ride rather than worrying about maintenance and adjustments. The easily adjustable Manitou Radium Expert rear shock serves up 120mm of smooth, progressive rear wheel travel while the plush RockShox Judy Silver fork offers super-precise, confidence-inspiring steering and 130mm of rock- and root-swallowing performance. And, because each uses an air spring, it's incredibly simple to set up according to your weight and preferred stiffness. We've added Sram's Eagle 1x12 transmission with its easy gear selection and incredibly wide, mountain-swallowing range, and fitted Shimano MT500 hydraulic disc brakes to ensure you're always in full control. It all adds up to a package that's guaranteed to put a smile on your face, ride after ride.



FRAME#HPA Advanced Hydroform, ATG, ETC 4-Link, AXH
SIZE#6", 18", 20", 22"
FORK#RockShox Judy Silver TK Air, Tapered, 15x110mm, 130mm, Lockout
SHOCK#Manitou Radium Expert RL, 190x45mm, Rebound Adjust, Lockout
SHOCK HARDWARE#op: 40x8mm, Bottom: 22x8mm



HEADSET#SA 1.5E ZS, Tapered, Top Zero-Stack 1 1/8" (OD 44mm), Bottom Zero-Stack 1 1/2" (OD 56mm)
STEM#Newmen Evolution 318.4, 31.8mm
HANDLEBAR#Newmen Evolution 318.20, 760mm
GRIPS#Cube Race SL Grip 29.5mm, 1-Clamp
REAR DERAILLEUR#Sram NX Eagle™, 12-Speed
SHIFTERS#Sram SX Eagle™ Trigger
BRAKE SYSTEM#Shimano BR-MT500, Hydr. Disc Brake (180/180)
CRANKSET#Sram X1 1000 Eagle™ DUB 30T, Boost, 175mm
CASSETTE#Sram XG-1230, 11-50T
CHAIN#Sram SX Eagle™
RIMS#CUBE EX25, 32H, Disc
FRONT HUB#Shimano HB-MT400-B, 15mm, Boost, Centerlock
REAR HUB#Shimano FH-MT400-B, 12mm, Boost, Centerlock
TYRES#Schwalbe Nobby Nic, Addix Performance, Kevlar, 2.35
SADDLE#Natural Fit Venec
SEAT POST#CUBE Dropper Post, Handlebar Lever, Internal Cable Routing, 31.6mm, 425x130mm (403x120mm for smallest frame size)
SEATCLAMP#CUBE Screwlock, 34.9mm



WEIGHT#4,9 kg



SPARE PARTS#

- 8510** CUBE Horstlink Set (19_FSV-120-29)
- 8514** CUBE Main Pivot Set (19_FSV-120-29)
- 8517** CUBE Rock Mount Set (19_FSV-120-29)
- 8523** CUBE Link to Shock (19_FSV-120-29)
- 8454** CUBE HANGER_mtb/rr-x12-std (18-06267)
- 10025** CUBE Disc Brake Pad Shimano Deore BR-M505/15/525/445/446
- 10338** CUBE Headset Orbit 1.5E ZS 1 1/8 / 1.5 semi + 1 1/8 crown race

FOR us #TrailSurfers

Lots of travel used to mean ungainly rockers, unsightly pivots and a clunky appearance. Not anymore. The Stereo 140 doesn't just ride better than many bikes in its class, it's also one of the most elegant frames we've made. Boasting a full carbon front end and carefully crafted aluminium rear triangle, our engineering team went out of their way to make it look as good as it rides. That's why the pivots are hidden away, the rocker is short and all the cables are routed internally. The Boost 148 rear end, massive down tube and tapered head tube mean super-accurate steering and instant power transfer, while shorter chain stays, a longer top tube and a head angle designed specially for a 150mm fork all add up to the kind of razor-sharp, rock-solid handling you'd expect from CUBE. We even remembered to fit ISCG05 tabs for a chain guide, so you can set it up exactly how you want. Your bike, your way.



STEREO 140 HPC TM 27.5

354300 grey'n'orange



10708
CUBE AM JERSEY



17095
CUBE SHOES GTY STRIX



10733
CUBE EDGE BAGGY SHORTS X ACTIONTEAM

When you're pushing your personal limits as well as your equipment's, you need a bike that won't let you down. That's where our Stereo 140 HPC TM 27.5 comes in – an uncompromising mountain tamer that puts ultimate performance and control front and centre. Based around the Stereo 140's carbon and aluminium chassis, our designers are rightly proud of this bike's pedigree and attention to detail. Pivots are hidden for clean looks and reduced maintenance, while the Boost 148 rear end, short rocker and tapered head tube all help make the most of the carbon frame's incredible stiffness. Paired with only the best components we could source, it makes for a bike that you'll just want to keep riding. For example, the Fox 36 Factory fork is paired with Fox Float DPX2 shock at the rear, providing up to 150mm (140mm at the rear) of smooth, controllable suspension travel to help tame the toughest of trails. Fast-accelerating and tough Newmen Evolution rims shod with Schwalbe tyres provide reliable, confidence-inspiring grip even at the limits, held in check by powerful Sram Code hydraulic disc brakes. There's a Fox Transfer dropper post to help you keep your weight low on tricky descents, of course. And Sram's 1x12 Eagle transmission – with carbon crank – has the range, precision and reliability to get you to your destination, whichever route you choose. Best of all, all of this matchless all mountain performance is wrapped in a package that's so good looking, no-one will believe how much travel is lurking beneath that svelte frame. The perfect all mountain machine? Well, we reckon it just might be. Now it's your turn to judge...

- SPARE PARTS#**
- 8507 CUBE Seat Stay to Link Set Stereo 140 HPC
 - 8654 CUBE HANGER_mtb/rr-x12-std [18-06267]
 - 10339 CUBE Headset Orbit I-T + 1 1/8 crown race

- FRAME#**HPC Carbon Monocoque Advanced Twin Mold Technology, Aluminum 6061 T6 Rear Triangle, ATG, ETC 4-Link, ISCG Mount, Boost 148, AXH
- SIZE#**6", 18", 20", 22"
- FORK#**ox 36 Float Factory FIT GRIP2, HSC/LSC & HSR/LSR, Tapered, 15x110mm, 150mm, Kashima Coated
- SHOCK#**ox Float DPX2 Factory EVOL, 185x52.5mm Trunnion Mount, Open(Adjustable)/Medium/Firm Mode, Kashima Coated
- SHOCK HARDWARE#**op: 54mm Trunnion Mount, Bottom: 22x8mm

- HEADSET#**SA Orbit I-t, Integrated, Top 1 1/8", Bottom 1 1/2"
- STEM#**Race Face Turbine R 35
- HANDLEBAR#**Race Face Next R 35 Carbon, 800mm
- GRIPS#**DG Slater
- REAR DERAILLEUR#**Sram GX Eagle™, 12-Speed
- SHIFTERS#**Sram NX Eagle™ Trigger
- BRAKE SYSTEM#**Sram Code R, Hydr. Disc Brake (200/180)
- CRANKSET#**Sram X1 Eagle™ Carbon DUB 32T, 175mm
- CASSETTE#**Sram XG-1275, 10-50T
- CHAIN#**Sram SX Eagle™
- CHAIN GUIDE#**MRP 1X Chain Guide
- WHEELSET#**Newmen Evolution SL A.30, 28/28 Spokes, 15x110mm / 12x148mm, Tubeless Ready
- FRONT TIRE#**Schwalbe Magic Mary, Addix Soft, Kevlar, Tubeless Easy, 2.35
- REAR TIRE#**Schwalbe Hans Dampf, Addix Speedgrip, Kevlar, Tubeless Easy, 2.35
- SADDLE#**DG Radar
- SEAT POST#**ox Transfer Factory 31.6mm, Kashima coated, 457x150mm (406x125mm for smallest frame size)
- SEATCLAMP#**CUBE Screwlock, 34.9mm

WEIGHT#2,9 kg

FULL SUSPENSION

STEREO 140 HPC SL 27.5

354200 carbon'n'grey

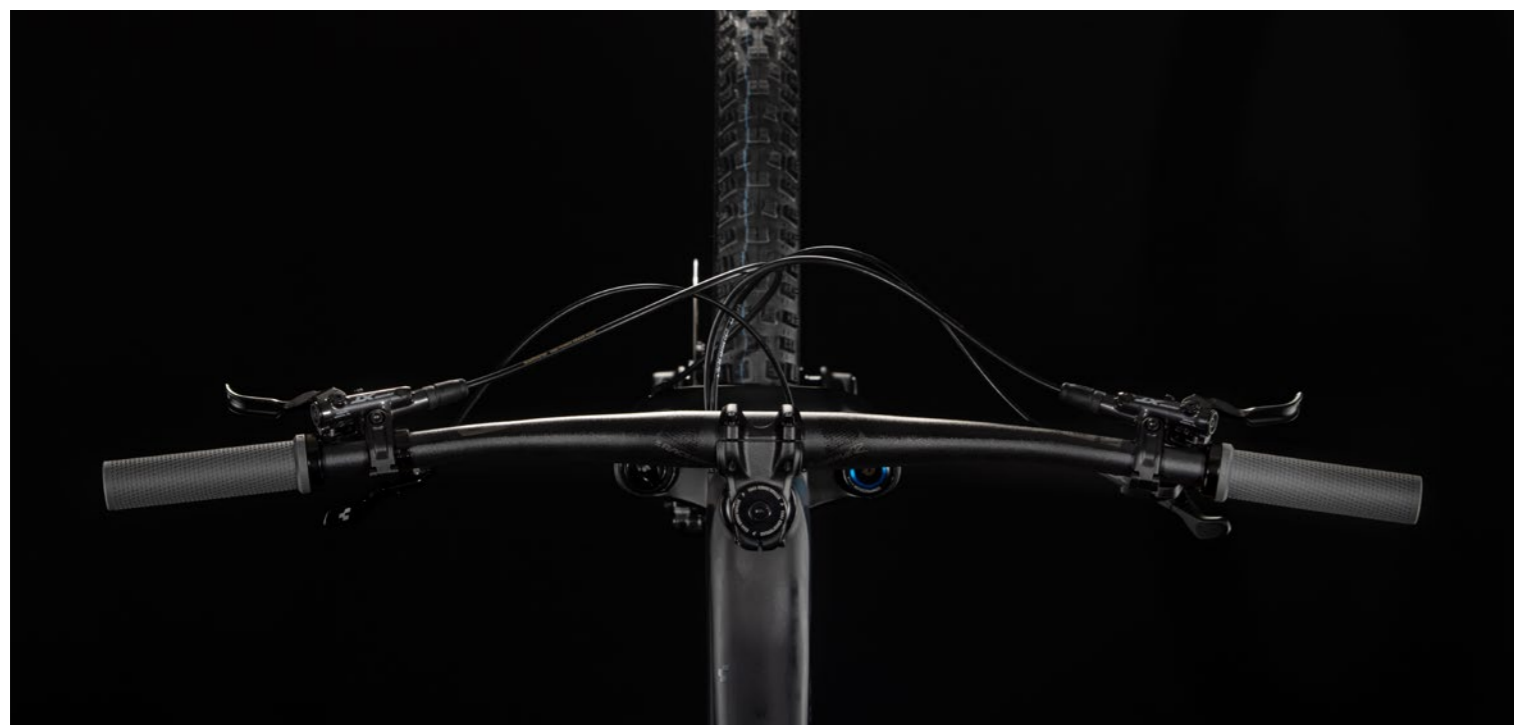

10688
CUBE AM BAGGY SHORTS



10679
CUBE AM JERSEY



10690
CUBE AM STORM JACKET



Big days out in the mountains place big demands on both bike and rider. Luckily the Stereo 140 HPC SL 27.5 is up for the challenge. This carbon and aluminium all mountain machine's svelte looks aren't its only attraction. Years of experience building full-suspension bikes have gone into details like the hidden rocker pivots, neat internal cable routing, superbly efficient kinematics and confidence-inspiring Agile Trail Geometry. Making the most of the resulting sharp handling and efficient power transfer meant, of course, specing some top-grade components. We began with a RockShox Pike Select+ fork and paired it with a RockShox Deluxe Select+ shock at the rear, for total control over bump absorption at any speed. Newmen's light, strong Evolution wheelset provides a solid base for anchoring a pair of Schwalbe's big-volume, grippy tyres and Shimano's 1x12 XT transmission and hydraulic disc brakes take care of stop-and-go duties. Add it all up, and it makes for a light, agile, fast and supremely capable companion on even the toughest of trails. Go explore – but make sure you take the Stereo 140 HPC SL with you for the ride.

FRAME#HPC Carbon Monocoque Advanced Twin Mold Technology, Aluminum 6061 T6 Rear Triangle, ATG, ETC 4-Link, ISCG Mount, Boost 148, AXH
SIZE#6", 18", 20", 22"
FORK#RockShox Pike Select+, 110x15mm, Tapered, 150mm
SHOCK#RockShox Deluxe Select+, 185x52.5mm Trunnion Mount, Rebound Adjust, Lockout
SHOCK HARDWARE#Top: 54mm Trunnion Mount, Bottom: 22x8mm

HEADSET#SA Orbit I-t, Integrated, Top 1 1/8", Bottom 1 1/2"
STEM#Race Face Aeffect R 35
HANDLEBAR#Race Face Turbine R 35, 780mm
GRIPS#CUBE Race SL Grip 29.5mm, 1-Clamp
REAR DERAILLEUR#Shimano XT RD-M8100-SGS, ShadowPlus, 12-Speed
SHIFTERS#Shimano SLX SL-M7100-I Direct Attach
BRAKE SYSTEM#Shimano XT BR-M8100, Hydr. Disc Brake [203/180]
CRANKSET#Shimano XT FC-M8100, 32T, Boost, 170mm
CASSETTE#Shimano SLX CS-M7100, 10-51T
CHAIN#Shimano CN-M7100
CHAIN GUIDE#MRP 1X Chain Guide
WHEELSET#Newmen Evolution SL A.30, 28/28 Spokes, 15x110mm / 12x148mm, Tubeless Ready
TYRES#Schwalbe Nobby Nic, Addix Speedgrip, Kevlar, Tubeless Easy, 2.35
SADDLE#Natural Fit Nuance Lite
SEAT POST#CUBE Dropper Post, Handlebar Lever, Internal Cable Routing, 31.6mm, 480x150mm [420x125mm for smallest frame size]
SEATCLAMP#CUBE Screwlock, 34.9mm

WEIGHT#2,7 kg

SPARE PARTS#
8507 CUBE Seat Stay to Link Set Stereo 140 HPC
8654 CUBE HANGER_mtb/rr-x12-std [18-06267]
10339 CUBE Headset Orbit I-T + 1 1/8 crown race

FULL SUSPENSION

STEREO 140 HPC RACE 27.5

354100 bluegrey'n'red



When we set out to design the Stereo 140 HPC Race we had a simple goal – to build a bike that would redefine expectations of an all-mountain machine. Light, nimble and versatile almost beyond your imagination, its carbon main frame and rocker, combined with an aluminium rear triangle and 150mm fork, is capable of taking you to places you never thought possible. We selected Fox's 34 Rhythm fork and Float DPS shock for front and rear air springs that are easy to set up, easy to adjust and with a performance that'll have you coming back for more, ride after ride. Combined with our hidden frame pivots, Agile Trail Geometry and refined kinematics, it's a setup that's tough to beat. The Shimano 12-speed SLX and XT transmission shifts cleanly and precisely in any conditions, thanks partly to internally routed cables, whilst tough Fulcrum wheels shod with wide, grippy Schwalbe tyres are anchored by powerful Shimano hydraulic disc brakes with a four-piston calliper up front. We even remembered to fit a dropper post, so you can ride even the steepest of chutes in complete control. The only thing that's missing is a rider. Will you step up?

FRAME#HPC Carbon Monocoque Advanced Twin Mold Technology, Aluminum 6061 T6 Rear Triangle, ATG, ETC 4-Link, ISCG Mount, Boost 148, AXH
SIZE#6", 18", 20", 22"
FORK#Fox 34 Rhythm, 2-Position Sweep-Adjust GRIP Damper, Tapered, 15x110mm, 150mm
SHOCK#Fox Float DPS EVOL, 185x52.5mm Trunnion Mount, Open/Medium/Firm Mode
SHOCK HARDWARE#Top: 54mm Trunnion Mount, Bottom: 22x8mm

HEADSET#SA Orbit I-t, Integrated, Top 1 1/8", Bottom 1 1/2"
STEM#Race Face Affect R 35
HANDLEBAR#Race Face Ride 35, 760mm
GRIPS#CUBE Race SL Grip 29.5mm, 1-Clamp
REAR DERAILLEUR#Shimano XT RD-M8100-SGS, ShadowPlus, 12-Speed
SHIFTERS#Shimano SLX SL-M7100
BRAKE SYSTEM#Shimano BR-MT500, Hydr. Disc Brake (203/180)
CRANKSET#Shimano FC-MT610, 32T, Boost, 170mm
CASSETTE#Shimano SLX CS-M7100, 10-51T
CHAIN#Shimano CN-M7100
WHEELSET#Fulcrum Red 55 EM, 28/28 Spokes, 15x110mm / 12x148mm, Tubeless Ready
TYRES#Schwalbe Nobby Nic, Addix Speedgrip, Kevlar, Tubeless Easy, 2.35
SADDLE#Natural Fit Nuance Lite
SEAT POST#CUBE Dropper Post, Handlebar Lever, Internal Cable Routing, 31.6mm, 425x130mm (403x120mm for smallest frame size)
SEATCLAMP#CUBE Screwlock, 34.9mm

WEIGHT#3,3 kg



11271
CUBE GRIPS RACE SL

11027
CUBE AM JERSEY

93068
ACID LED LIGHT HPA 1300

SPARE PARTS#
8507 CUBE Seat Stay to Link Set Stereo 140 HPC
8654 CUBE HANGER_mtb/rr-x12-std [18-06267]
10339 CUBE Headset Orbit I-T + 1 1/8 crown race

FULL SUSPENSION

FOR us #EnduroPilots

How do you combine mountain goat agility with mountain lion speed? A good start is to ask CUBE engineers to do the seemingly impossible and build a bike that climbs almost as well as it descends. The result is the Stereo 150 29's elegantly sculpted C:68 carbon frame. The clean lines, rocker cover and trunnion-mount shock are designed to combine efficiency, stability and intuitive handling. Boost 148 rear axle spacing works together with the tapered head tube and oversized down tube to deliver unparalleled steering precision and pedal input. ISCG05 tabs for a chain guide are standard, while short chain stays ensure agile handling and, in combination with the 75.5-degree seat tube, provide efficient climbing. The low standover and head tube specifically designed for a 160mm fork add the confidence, control and precision you need for sure-footed descending. Jack of all trades? We prefer to think it's master of them all.



STEREO 150 C:68 SLT 29

355400 carbon'n'red



The Stereo 150 C:68 SLT is our go-anywhere, ride-anything enduro race machine. Surprisingly light, supremely nimble and utterly assured in any trail situation, we've thrown everything at our range-topping, Alpedevouring machine to make sure that it's the best of the EWS best. Built around our C:68 carbon Stereo 150 chassis, we started as we meant to go on – with obsessive attention to detail and a focus on ultimate performance. We selected a RockShox Super Deluxe Ultimate shock for the rear, and matched it to a RockShox Lyrik Ultimate RC2 for the front for balanced, plush and controllable suspension performance at any speed. Wide Maxxis tyres on light, tough Newmen Evolution wheels offer the reassurance of bucketloads of grip and cushioning, no matter how hard you ride. Sram's X01 Eagle 12-speed transmission serves up crisp, reliable shifting and an extraordinary gear range capable of taking on any trail or race course. And bringing it all reliably to a halt is a set of Sram's powerful G2 Ultimate hydraulic disc brakes with a large 200mm rotor up front for better cooling on long, fast or steep descents. The RockShox Reverb Stealth dropper post gets out of your way at the push of a button, and RaceFace cockpit components keep you on point and on your line. Refined geometry features a 66-degree head angle – perfect for a 160mm fork – with a 75.5-degree seat angle for efficient climbing, whilst 435mm chain stays ensure on-demand handling in tight and twisty singletrack. There's a built-in ISCG05 chain guide tab, while Boost 148 rear wheel spacing works with careful tube profiling and the tapered steerer to deliver superbly precise steering and tracking. Put it all together, and you can almost sense the podium beckoning. Are you up for it? Because the Stereo 150 C:68 SLT definitely is.

FRAME #C:68 Monocoque Advanced Twin Mold Technology, ATG, ETC 4-Link, ISCG Mount, Boost 148, AXH
SIZE #6", 18", 20", 22"
FORK #RockShox Lyrik Ultimate RC2, 110x15mm, Tapered, 160mm
SHOCK #RockShox Super Deluxe Ultimate DebonAir, 185x55mm, Trunnion Mount
SHOCK HARDWARE #Top: 54mm Trunnion Mount, Bottom: 22x8mm

HEADSET #SA Orbit I-t, Integrated, Top 1 1/8", Bottom 1 1/2"
STEM #Race Face Turbine R 35
HANDLEBAR #Race Face Next R 35 Carbon, 800mm
GRIPS #CUBE Race SL Grip 29.5mm, 1-Clamp
REAR DERAILLEUR #Sram X01 Eagle™, 12-Speed
SHIFTERS #Sram X01 Eagle™ Trigger
BRAKE SYSTEM #Sram G2 Ultimate, Hydr. Disc Brake (200/180)
CRANKSET #Sram X01 Eagle™ Carbon 30T, Boost, 170mm
CASSETTE #Sram XG-1295, 10-50T
CHAIN #Sram PC-X01 Eagle™
CHAIN GUIDE #MRP 1X Chain Guide
WHEELSET #Newmen Evolution SL A.30, 28/28 Spokes, 15x110mm / 12x148mm, Tubeless Ready
FRONT TIRE #Maxxis Minion DHF, MaxxTerra/EXO, Tubeless Ready, 29 x 2.5 WT
REAR TIRE #Maxxis Minion DHR II, MaxxTerra/EXO, Tubeless Ready, 29 x 2.4 WT
SADDLE #DG Radar
SEAT POST #RockShox Reverb Stealth 1X, 31.6mm, 414x150mm (351x125mm for smallest frame size)
SEATCLAMP #CUBE Screwlock, 34.9mm

WEIGHT #2,9 kg

SPARE PARTS
8654 CUBE HANGER_mtb/rr-x12-std (18-06267)
10339 CUBE Headset Orbit I-T + 1 1/8 crown race



13096
CUBE BOTTLE CAGE HPC 2.0

10777
CUBE EDGE BAGGY SHORTS

10766
CUBE EDGE JERSEY

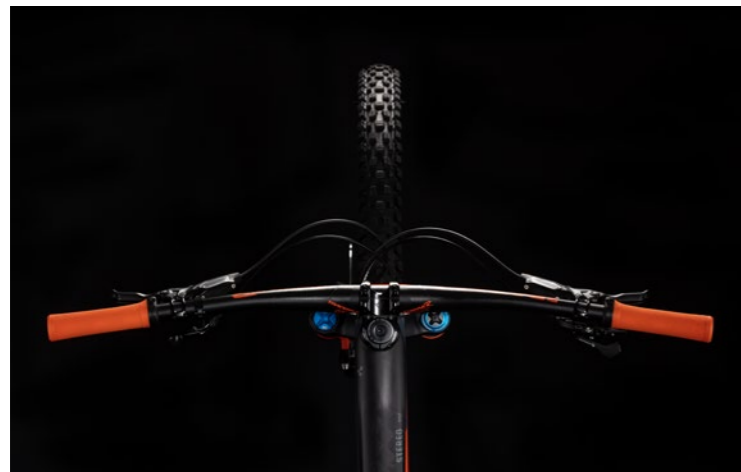

There was a time when true mountain-taming descending ability came with a side order of uphill sluggishness. It wasn't that long ago, and it was enough to make a lot of enduro bikes a frustrating handful. But that time is now firmly in the past. Meet the Stereo 150 C:68 TM 29 – an enduro bike that'll recalibrate your expectations of what's possible on a mountain bike. Built around a chassis crafted from our premium C:68 carbon, it's an extraordinarily race-capable all-rounder that's very nearly as adept at propelling its rider skyward as it is at cashing in gravity credits on the way back down. Short 435mm chain stays, a head tube designed around a 160mm fork and a steep 75.5-degree seat angle for agile handling and efficient climbing are all part of the package. We chose Sram's amazing 1x12 Eagle transmission for its simplicity, reliability and awesome gear range, and paired it with powerful Sram G2 RSC hydraulic disc brakes with a 200mm front rotor for the ultimate in stopping power. Big-volume, super-grippy Maxxis tyres wrapped around light, strong Newmen Evolution wheels are kept in contact with terra firma thanks to a Fox 36 Float Factory fork up front and Float X2 Factory shock at the rear. Even the Fox Transfer dropper post features a Kashima coating, so you can drop the saddle at the push of a button for better control in super-techy trail situations. But that's the kind of attention to detail we like to lavish on our bikes, so that you can concentrate on the ride. And with the Stereo 150 C:68 TM 29 you'll be able to ride every trail, everywhere, faster and smoother.

FRAME# C:68 Monocoque Advanced Twin Mold Technology, ATG, ETC 4-Link, ISCG Mount, Boost 148, AXH
SIZE# 6", 18", 20", 22"
FORK# Fox 36 Float FIT GRIP2 Factory, Tapered, 15x110mm, 160mm, Kashima Coated
SHOCK# Fox Float X2 Factory, 185x55mm Trunnion Mount, High/Low Speed Rebound & Compression w/ 2-Position Lever, Kashima Coated
SHOCK HARDWARE# Top: 54mm Trunnion Mount, Bottom: 22x8mm

HEADSET# SA Orbit I-t, Integrated, Top 1 1/8", Bottom 1 1/2"
STEM# Race Face Turbine R 35
HANDLEBAR# Race Face Turbine R 35, 800mm
GRIPS# DG Slater
REAR DERAILLEUR# Sram GX Eagle™, 12-Speed
SHIFTERS# Sram NX Eagle™ Trigger
BRAKE SYSTEM# Sram G2 RSC, Hydr. Disc Brake (200/180)
CRANKSET# Sram X1 Eagle™ Carbon DUB 30T
CASSETTE# Sram XG-1275, 10-50T
CHAIN# Sram SX Eagle™
CHAIN GUIDE# MRP SXG Chain Guide
WHEELSET# Newmen Evolution SL A.30, 28/28 Spokes, 15x110mm / 12x148mm, Tubeless Ready
FRONT TIRE# Maxxis Assegai, MaxxTerra/EXO+, Tubeless Ready, 29 x 2.5 WT
REAR TIRE# Maxxis Minion DHR II, MaxxTerra/EXO+, Tubeless Ready, 29 x 2.4 WT
SADDLE# DG Radar
SEAT POST# Fox Transfer Factory 31.6mm, Kashima coated, 457x150mm (406x125mm for smallest frame size)
SEATCLAMP# CUBE Screwlock, 34.9mm

WEIGHT# 3,9 kg

SPARE PARTS#
8654 CUBE HANGER_mtb/rr-x12-std (18-06267)
10339 CUBE Headset Orbit I-T + 1 1/8 crown race



17070
CUBE SHOES GTY MAZE X ACTIONTEAM



10710
CUBE AM JERSEY



16250
CUBE HELMET BADGER



A lot has changed since we built our first Stereo full-suspension bike. But that's OK, because there's nothing our engineers enjoy more than the challenge of producing a better bike than the one they did before. Which brings us neatly to the Stereo 150 C:62 SL 29 – a bike that condenses everything we know about building light, fast and versatile bikes into a sleek, elegant and hard-hitting all-rounder for the enduro enthusiast and Alpine-addicted. With its elegant C:62 carbon chassis and ample clearance for big-volume 29er tyres, our design team left nothing to chance. ISCG05 tabs for a chain guide are standard, cables are all routed internally for long-lasting clean shifting, and the whole chassis is designed to accommodate 160mm of fork travel. In the case of the Stereo 150 C:62 SL 29, that particular duty falls to a Fox 36 Float Factory fork, paired with a matching Fox Float DPX2 Factory shock at the rear for seemingly bottomless, smooth and progressive rock-swallowing performance. There's also a Fox Transfer Factory dropper post with remote control, so you can tuck the saddle out of the way on particularly tricky trail sections. The light, stiff XT crank works seamlessly with Shimano's new 12-speed components to deliver a huge 510% gear range, while four-piston XT hydraulic disc callipers at both ends give you the power you'll need to keep your speed safely in check. It all rolls on Newmen's light, stiff and amazingly strong Evolution wheelset, shod with Schwalbe's Addix tyres for the ultimate in grip and cushioning in any trail conditions. However steep the mountainside, however tough the trail, this bike's got your back. Are you up for it?

FRAME #C:62 Monocoque Advanced Twin Mold Technology, ATG, ETC 4-Link, ISCG Mount, Boost 148, AXH
SIZE #6", 18", 20", 22"
FORK #Fox 36 Float FIT GRIP2 Factory, Tapered, 15x110mm, 160mm, Kashima Coated
SHOCK #Fox Float DPX2 Factory EVOL, 185x55mm Trunnion Mount, Open(Adjustable)/Medium/Firm Mode, Kashima Coated
SHOCK HARDWARE #Top: 54mm Trunnion Mount, Bottom: 22x8mm

HEADSET #SA Orbit I-t, Integrated, Top 1 1/8", Bottom 1 1/2"
STEM #Race Face Aeffect R 35
HANDLEBAR #Race Face Chester 35, 780mm
GRIPS #CUBE Race SL Grip 29.5mm, 1-Clamp
REAR DERAILLEUR #Shimano XT RD-M8100-SGS, ShadowPlus, 12-Speed
SHIFTERS #Shimano SLX SL-M7100-I Direct Attach
BRAKE SYSTEM #Shimano XT BR-M8120, Hydr. Disc Brake (203/180)
CRANKSET #Shimano XT FC-M8100, 32T, Boost, 170mm
CASSETTE #Shimano SLX CS-M7100, 10-51T
CHAIN #Shimano CN-M7100
CHAIN GUIDE #MRP 1X Chain Guide
WHEELSET #Newmen Evolution SL A.30, 28/28 Spokes, 15x110mm / 12x148mm, Tubeless Ready
FRONT TIRE #Schwalbe Magic Mary, Addix Soft, Kevlar, Tubeless Easy, 2.35
REAR TIRE #Schwalbe Hans Dampf, Addix Speedgrip, Kevlar, Tubeless Easy, 2.35
SADDLE #Natural Fit Nuance Lite
SEAT POST #Fox Transfer Factory 31.6mm, Kashima coated, 457x150mm (406x125mm for smallest frame size)
SEATCLAMP #CUBE Screwlock, 34.9mm

WEIGHT #3.6 kg

SPARE PARTS
8654 CUBE HANGER_mtb/rr-x12-std (18-06267)
10339 CUBE Headset Orbit I-T + 1 1/8 crown race



10772
 CUBE EDGE JERSEY X ACTIONTEAM

10733
 CUBE EDGE BAGGY SHORTS X ACTIONTEAM

16242
 CUBE HELMET BADGER

STEREO 150 C:62 RACE 29

355100 grey'n'carbon



What do you call a bike that's as rock-solid dependable descending an Alp as it is agile and sure-footed picking a route up the climb the other side of the valley? The CUBE engineering and factory race teams have the answer: the Stereo 150 C:62 Race 29. We took all the experience we gained building race-winning bikes for the Enduro World Series, and condensed it into a bike that'll inspire you to do more. Careful tube profiling, Boost 148 rear axle spacing and a tapered head tube give this frame a rigidity that belies its svelte appearance, so that you can rely on it to transfer every watt of pedal power into forward motion and respond instantly to steering input. C:62 carbon and our design team's long experience of working with this amazing material ensure that it's got the durability and strength to stay the course, too. But we didn't stop there. Smooth-rolling Fulcrum 29er wheels and big-volume Maxxis tyres give you the grip you'll need to tame any mountain trail, whether up or down. Keeping all that rubber on the ground is a pair of RockShox air springs – a Lyrik Select Charger fork up front and Super Deluxe Select+ shock at the rear. Powerful Magura hydraulic disc brakes help keep your speed in check, and Sram's legendary Eagle 1x12 transmission gives you the range you need to tackle any climb or descent. Topped off with a remote dropper post for those particularly tricky steep chutes, it's got ride-anywhere versatility written all over it. Actually, it hasn't – our design team wouldn't let us. But, as a Stereo 150 C:62 Race 29 rider you'll just know: this bike rocks.

FRAME# C:62 Monocoque Advanced Twin Mold Technology, ATG, ETC 4-Link, ISCG Mount, Boost 148, AXH
SIZE# 6", 18", 20", 22"
FORK# RockShox Lyrik Select, 110x15mm, Tapered, 160mm
SHOCK# RockShox Super Deluxe Select+ DebonAir, 185x55mm, Trunnion Mount
SHOCK HARDWARE# Top: 54mm Trunnion Mount, Bottom: 22x8mm

HEADSET# SA Orbit I-t, Integrated, Top 1 1/8", Bottom 1 1/2"
STEM# Race Face Affect R 35
HANDLEBAR# Race Face Chester 35, 780mm
GRIPS# CUBE Race SL Grip 29.5mm, 1-Clamp
REAR DERAILLEUR# Sram GX Eagle™, 12-Speed
SHIFTERS# Sram NX Eagle™ Trigger
BRAKE SYSTEM# Magura MT Thirty, Hydr. Disc Brake (203/180)
CRANKSET# Sram X1 1000 Eagle™ DUB 30T, Boost, 175mm
CASSETTE# Sram XG-1230, 11-50T
CHAIN# Sram SX Eagle™
WHEELSET# Fulcrum Red 55 EM, 28/28 Spokes, 15x110mm / 12x148mm, Tubeless Ready
FRONT TIRE# Maxxis Minion DHF, MaxxTerra/EXO, Tubeless Ready, 29 x 2.5 WT
REAR TIRE# Maxxis Minion DHR II, MaxxTerra/EXO, Tubeless Ready, 29 x 2.4 WT
SADDLE# Natural Fit Nuance Lite
SEAT POST# CUBE Dropper Post, Handlebar Lever, Internal Cable Routing, 31.6mm, 480x150mm (420x125mm for smallest frame size)
SEATCLAMP# CUBE Screwlock, 34.9mm

WEIGHT# 3.9 kg

SPARE PARTS#
10339 CUBE Headset Orbit I-T + 1 1/8 crown race
8654 CUBE HANGER_mtb/tr-x12-std (18-06267)



12103
CUBE BACKPACK EDGE TWENTY

13026
CUBE BOTTLE CAGE HPP

17071
CUBE SHOES GTY MAZE CANVAS

FOR us #KOMHunters

There's nothing our engineering team like more than a challenge. So when we asked them to create a genuine big hit-capable full-suspension frame with clearance for wide 29er tyres, they didn't look at us as though we were mad. They just got down to work. Using all the experience they've gained from years of refining our four-bar suspension design, they tweaked the position of every linkage and frame joint until they were happy with the result, then refined every tube profile for the optimum blend of weight, strength and efficiency. With a short linkage, shock mount and covered bearings, it's clearly part of the CUBE full suspension family. Agile Trail Geometry and advanced suspension kinematics result in an exceptionally adept mountain tamer, with progressive suspension and a confidence-inspiring feeling on the trail. Hydroformed tubes, internally routed cables and our design team's usual fastidious attention to detail mean that it looks as good as it rides. So the only remaining question is, will you accept the challenge and push your boundaries? Because this is a frame that proves it can be done.



STEREO 170 SL 29

356300 black anodized

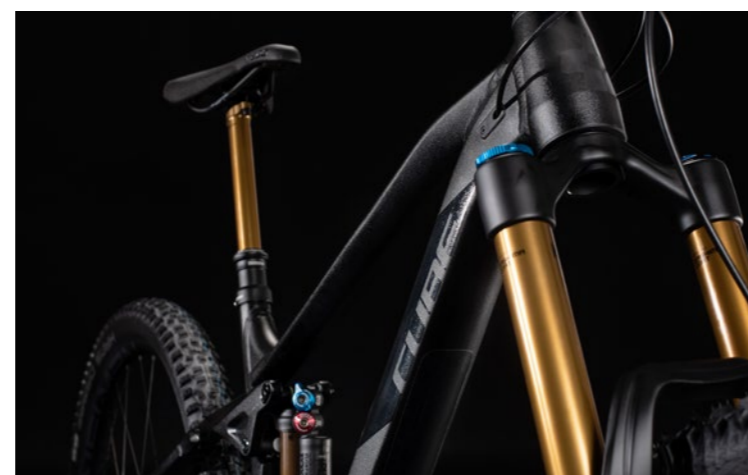

16240
CUBE HELMET BADGER

93250
ACID PEDALS FLAT A1-CB

10723
CUBE SHOES GTY MAZE

Bikes capable of being ridden at speed down big mountains, taking equally big hits in their stride, used to be one-trick ponies. Not anymore. The Stereo 170 SL 29 grabs the big-travel suspension rule book, rips it up and throws it off the nearest available metaphorical cliff. But that's the only sense in which it's even remotely unruly. Surprisingly light and agile, equipped with fast-rolling 29er wheels and featuring a full 170mm of smooth, controlled suspension travel, it redefines what's possible with big wheels and lots of travel. Shimano's new 1x12 XT transmission offers legendarily reliable smooth shifting and an unparalleled gear range. Combined with the refined kinematics, short linkage and covered pivots of our four-bar suspension system, it makes pedalling up the mountain you've just ridden down a realistic and achievable option. The Fox Float X2 Factory shock and Fox 36 Float Factory fork work together to serve up 170mm of smooth, progressive and controllable travel – refined under pedalling and unflappable even on big hits. Newmen Evolution wheels wrapped with Schwalbe Magic Mary and Hans Dampf 2.35in tyres grip tenaciously to the trail, while Shimano's bombproof XT four-piston hydraulic disc brakes, RaceFace cockpit components and Fox Transfer Factory dropper post ensure you'll always be in full control, no matter how lairy the descent. Don't let people tell you that you can't have it all. You really can, and this bike is the proof. You get one shot at life – you might as well ride it as hard as you dare.

FRAME #IPA Advanced Hydroform, ATG, ETC 4-Link, Air/Coil Shock Mount Flip-Chip, ISCG Mount, AXH
SIZE #8", 20", 22"
FORK #Fox 36 Float FIT GRIP2 Factory, Tapered, 15x110mm, 170mm, Kashima Coated
SHOCK #Fox Float X2 Factory, 230x62.5mm, High/Low Speed Rebound & Compression w/ 2-Position Lever, Kashima Coated
SHOCK HARDWARE #Top: 40x8mm, Bottom: 20x8mm

HEADSET #CROS Integrated, Top 1 1/8", Bottom 1 1/2", Fiber Inserts for 0.6° Angle Adjustment
STEM #Race Face Turbine R 35
HANDLEBAR #Race Face Next R 35 Carbon, 800mm
GRIPS #DG Slater
REAR DERAILLEUR #Shimano XT RD-M8100-SGS, ShadowPlus, 12-Speed
SHIFTERS #Shimano XT SL-M8100-IR, Direct Attach
BRAKE SYSTEMS #Shimano XT BR-M8120, Hydr. Disc Brake (203/180)
CRANKSET #Race Face Next R Carbon, 32T, 170mm
CASSETTE #Shimano XT CS-M8100, 10-51T
CHAIN #Shimano CN-M7100
CHAIN GUIDE #MRP SXG Chain Guide
WHEELSET #Newmen Evolution SL A.30, 28/28 Spokes, 15x110mm / 12x148mm, Tubeless Ready
FRONT TIRE #Schwalbe Magic Mary, Addix Soft, Kevlar, Tubeless Easy, 2.35
REAR TIRE #Schwalbe Hans Dampf, Addix Speedgrip, Kevlar, Tubeless Easy, 2.35
SADDLE #DG Radar
SEAT POST #Fox Transfer Factory 31.6mm, Kashima coated, 457x150mm (406x125mm for smallest frame size)
SEATCLAMP #CUBE Screwlock, 34.9mm

WEIGHT #4,4 kg

SPARE PARTS
8654 CUBE HANGER_mtb/rr-x12-std (18-06267)
10031 CUBE Disc Brake Pad Shimano New Saint

FULL SUSPENSION



It wasn't too long ago when people laughed at 29er wheels. Well, with the Stereo 170 TM 29 they're definitely not laughing now. A mountain-flattening machine with surprisingly agile handling and an ability to swallow daunting trail obstacles whole and spit them out in manageable-sized chunks, it's proof that you can have your cake and eat it. We've ploughed all our experience of building great-riding four-bar full-suspension bikes into engineering this frame, resulting in a big-travel big wheeler that defies both gravity and expectations. As usual, the devil is in the detail – and we've sweated those to provide longer travel up front and more progressive shock performance at the rear. How? The 180mm RockShox Lyrik fork is complemented by an angle-set in the slack position for better handling, while the TwistLoc actuated RockShox Super Deluxe rear shock's flip chip gives hard-charging riders the control and progression they need on the big hits. The short rocker, covered pivots and rock solid e*thirteen bar and stem combo all help keep everything on track even when the trail's getting rowdy, so you can just concentrate on nudging your limits. A dropper post ensures you can laugh in the face of 'impossible' lines, while powerful four-piston Shimano XT hydraulic disc brakes haul the e*thirteen wheelset and 2.35in tyre combo to a stop in any weather and on any trail and the 1x12 Shimano XT transmission gives you the gear range you need to tackle any trail, down or – yes – up. Is this bike all things to all riders? No. But if you like your trails steep, relentless and fast, the Stereo 170 TM 29 has got your back. And that's got to feel good, right?

FRAME#IPA Advanced Hydroform, ATG, ETC 4-Link, Air/Coil Shock Mount Flip-Chip, ISCG Mount, AXH
SIZE#8", 20", 22"
FORK#RockShox Lyrik Ultimate RC2, 110x15mm, Tapered, 180mm
SHOCK#RockShox Super Deluxe Coil Ultimate Remote, 230x65mm, TwistLoc Remote Lever
SHOCK HARDWARE#op: 40x8mm, Bottom: 28x8mm

HEADSET#CROS Integrated, Top 1 1/8", Bottom 1 1/2", Fiber Inserts for 0.6° Angle Adjustment
STEM#e*thirteen Plus 35
HANDLEBAR#e*thirteen Plus 35, 800mm
GRIPS#RockShox TwistLoc w/ fixed grip
REAR DERAILLEUR#Shimano XT RD-M8100-SGS, ShadowPlus, 12-Speed
SHIFTERS#Shimano SLX SL-M7100-I Direct Attach
BRAKE SYSTEM#Shimano XT BR-M8120, Hydr. Disc Brake (203/180)
CRANKSET#Shimano XT FC-M8100, 30T, Boost, 170mm
CASSETTE#e*thirteen TRS+, 9-50T
CHAIN#Shimano CN-M7100
CHAIN GUIDE#e*thirteen TRS+
WHEELSET#e*thirteen LG1 EN Plus, 15x110mm / 12x148mm, Tubeless Ready
FRONT TIRE#e*thirteen LG1 EN A/T Race, 42A/52A Compound, Apex, 2.35
REAR TIRE#e*thirteen LG1 EN A/T Plus, 52A/66A Compound, Apex, 2.35
SADDLE#DG Radar
SEAT POST#CUBE Dropper Post, Handlebar Lever, Internal Cable Routing, 31.6mm, 480x150mm
SEATCLAMP#CUBE Screwlock, 34.9mm

WEIGHT#5,4 kg

SPARE PARTS#
8654 CUBE HANGER_mtb/rr-x12-std (18-06267)
10031 CUBE Disc Brake Pad Shimano New Saint

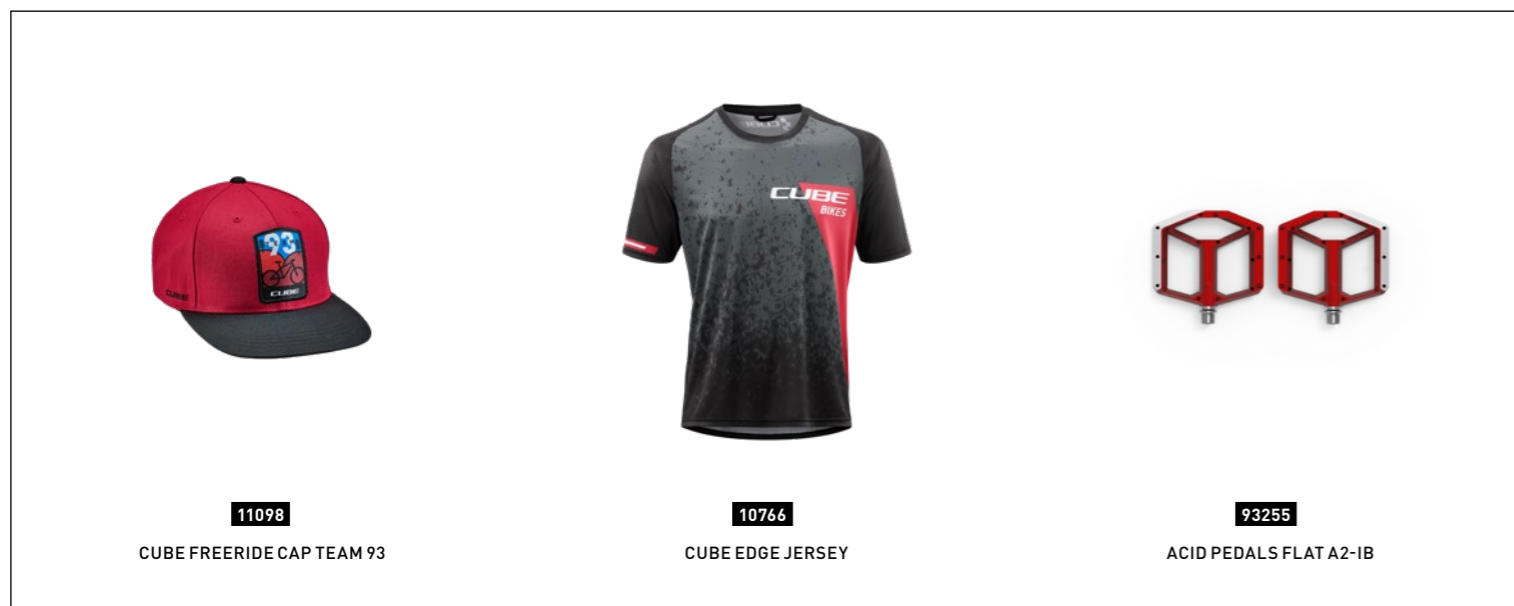

11098
CUBE FREERIDE CAP TEAM 93

10766
CUBE EDGE JERSEY

93255
ACID PEDALS FLAT A2-1B

STEREO 170 RACE 29

356100 green'n'sharpgreen



10687
CUBE AM BAGGY SHORTS



11841
CUBE SOCKS MOUNTAIN HIGH CUT



16243
CUBE HELMET BADGER

Those people who tell you that you can't have it all? They're wrong. And they definitely haven't seen the brand-new Stereo 170 Race 29, which distills all our engineering team's full-suspension expertise into a go-anywhere, ride-anything, gravity-surfing fun machine. Think fast-rolling 29er wheels won't work with big travel? Think again. Clever design and years of suspension kinematics experience have gone into this bike's 170mm travel frame – you'll be thankful of those big-diameter, grippy Maxxis EXO+ sneakers when you're nudging the limits of Alpine trail riding. Covered pivots, short linkage and elegant design with the emphasis on accurate tracking and steering – all the Stereo family's hallmarks are present and correct. And, because you'll be riding at speeds you didn't think possible, we've equipped the Stereo 170 Race 29 with the kit you'll need to keep the rubber side down and rolling. So there's a Fox 36 Float fork up front and matching Float DPX2 shock at the rear taking care of rock-swallowing duties. A Race Face cockpit, 150mm dropper post and powerful Sram Code R hydraulic disc brakes with a big 200mm front rotor ensure you're always in full control. And Sram's legendary 1x12 Eagle transmission gives you the gear range you need to ride back up the mountain, once you've finished riding down it. It's so much fun, there ought to be a law against it...

FRAME#IPA Advanced Hydroform, ATG, ETC 4-Link, Air/Coil Shock Mount Flip-Chip, ISCG Mount, AXH
SIZE#8", 20", 22"
FORK#ox 36 Float GRIP, 3-Position w/ Micro Adjust, Tapered, 15x110mm, 170mm
SHOCK#ox Float DPX2 EVOL, 230x62.5mm, Open/Medium/Firm Mode
SHOCK HARDWARE#op: 40x8mm, Bottom: 20x8mm

HEADSET#CROS Integrated, Top 1 1/8", Bottom 1 1/2", Fiber Inserts for 0.6° Angle Adjustment
STEM#Race Face Aeffect R 35
HANDLEBAR#Race Face Chester 35, 780mm
GRIPS#CUBE Race SL Grip 29.5mm, 1-Clamp
REAR DERAILLEUR#Sram GX Eagle™, 12-Speed
SHIFTERS#Sram GX Eagle™ Trigger
BRAKE SYSTEM#Sram Code R, Hydr. Disc Brake (200/180)
CRANKSET#Sram GX Eagle™ 30T, 170mm
CASSETTE#Sram XG-1230, 11-50T
CHAIN#Sram SX Eagle™
CHAIN GUIDE#MRP SXG Chain Guide
WHEELSET#Newmen Evolution SL A.30, 28/28 Spokes, 15x110mm / 12x148mm, Tubeless Ready
FRONT TIRE#Maxxis Assegai, MaxxTerra/EXO+, Tubeless Ready, 29 x 2.5 WT
REAR TIRE#Maxxis Minion DHR II, MaxxTerra/EXO+, Tubeless Ready, 29 x 2.4 WT
SADDLE#Natural Fit Venec
SEAT POST#CUBE Dropper Post, Handlebar Lever, Internal Cable Routing, 31.6mm, 480x150mm
SEATCLAMP#CUBE Screwlock, 34.9mm

WEIGHT#5,4 kg

SPARE PARTS#
8654 CUBE HANGER_mtb/rr-x12-std [18-06267]
10041 CUBE Disc Brake Pad Avid Code 2011
10042 CUBE Disc Brake Pad Avid Code 2011

FULL SUSPENSION

FOR us #Racers

Hands up who thinks that downhill and bike park bikes are ungainly, heavy and inefficient? Yeah, we thought so. If that's your opinion, you haven't met our Two15. With suspension kinematics tuned to be progressive for big hits but with more than a hint of the efficiency of our trail bikes, it's more agile than such a big-hitter has any right to be. But we didn't stop with the kinematics, because our engineers also put a lot of effort into reducing weight. The Two15's hydroformed, triple-butted tubeset with 157mm rear hub spacing weighs only a bit more than an enduro frame, but delivers extraordinary steering precision and epic rock-swallowing capability. And details like the internal cable routing are the icing on the cake, delivering millimetre-perfect gear shifts every time, in even the worst riding conditions. Take on gravity, and show it who's boss...



FULL SUSPENSION



FULL SUSPENSION

Whether it's battling against the clock on a World Cup downhill course or having a blast in the bike park, the Two015 SL is up for it. Its hydroformed, triple-butted tubeset with 157mm rear hub spacing weighs only slightly more than an Enduro frame, but delivers extraordinary steering precision and epic rock-swallowing ability. The four-bar suspension design has similar suspension characteristics to our super-efficient trail bikes, but with noticeably better agility and control than some simpler DH designs. The result? It's both lighter than you'd expect and reassuringly bomb-proof. Lower weight makes it easier to handle, and better handling translates to more speed... and more speed is what it's all about, right? Backing up this no-nonsense frame design is a premium crop of components to give the Two015 SL the competitive edge it deserves. A RaceFace cockpit combines with Sram's GX DH 7-speed transmission and Magura MT7 hydraulic disc brakes to put you firmly in control. A light, tough DT Swiss wheelset is wrapped in Schwalbe's Magic Mary tyres to provide you with the grip and control that you need, while a Fox 40/49 Factory fork and matching Float X2 Factory shock keep the rubber side down, no matter how hard you shred. Are you ready? Because the Two015 SL most certainly is...

-  **FRAME#**HPA Ultralight, Advanced Hydroform, Triple Butted, ETC 4-Link, ISCG Mount, 215mm travel (29": 200mm)
- SIZE#**M / 27.5, L / 29, XL / 29
- FORK#**ox 40/49 Float Factory GRIP2, 20x110mm, 203mm, Kashima Coated
- SHOCK#**ox Float X2 Factory, 240x76mm, High/Low Speed Rebound & Compression, Kashima Coated
- SHOCK HARDWARE#**op: 30x8mm, Bottom: 22x8mm

-  **HEADSET#**ane Creek 40.ZS49 / 40.EC49\30
- STEM#**ace Face Chester 35 Direct Mount
- HANDLEBAR#**ace Face Atlas 35 800mm 35mm
- GRIPS#**DG Slater
- REAR DERAILLEUR#**ram GX DH, 7-Speed
- SHIFTERS#**ram GX Trigger
- BRAKE SYSTEM#**agura MT7, Hydr. Disc Brake (203/180)
- CRANKSET#**ace Face Atlas 36T, 165mm
- CASSETTE#**ram PG-720, 11-25T
- CHAIN#**ram PC-1110
- CHAIN GUIDE#**MRP G3 Chain Guide, 34-38T, ISCG05
- WHEELSET#**T CSW DH 3.7 / 3.9, 20mm / 157x12mm, Tubeless Ready
- FRONT TIRE#**chwalbe Magic Mary, Addix Ultrasoft, Kevlar, Super Gravity, Tubeless Easy, 2.35
- REAR TIRE#**chwalbe Magic Mary, Addix Soft, Kevlar, Super Gravity, Tubeless Easy, 2.35
- SADDLE#**DG FLY MTN 2
- SEAT POST#**UBE Performance Post, 31.6mm
- SEATCLAMP#**UBE Screwlock, 34.9mm

 **WEIGHT#**6,3 kg

-  **SPARE PARTS#**
- 8512** CUBE Main Pivot Set (16_FSV_215_650B) (19_FSV-200-29)
- 8515** CUBE Rock Mount Set (16_FSV_215_650B) (19_FSV-200-29)
- 8521** CUBE Link to Shock (16_FSV_215_650B) (19_FSV-200-29)
- 8524** CUBE Shock Mount Set (16_FSV_215_650B) (19_FSV-200-29)
- 8654** CUBE HANGER_mtb/rr-x12-std (18-06267)
- 10057** CUBE Disc Brake Pad Magura MT7
- 10058** CUBE Disc Brake Pad Magura MT7



16111
CUBE HELMET STATUS X 100%



17070
CUBE SHOES GTY MAZE X ACTIONTEAM



11945
CUBE GLOVES PERFORMANCE

ROAD RACE



- 144 **LITENING** C:68X
- 154 **AGREE** C:62
- 162 **ATTAIN** GTC
- 168 **ATTAIN** HPA
- 178 **CROSS RACE** C:62
- 184 **CROSS RACE** HPA
- 192 **NUROAD** HPA
- 204 **SL ROAD**

	COMFORT	ENDURANCE	RACE
LITENING C:68X			■
AGREE C:62	■	■	■
ATTAIN GTC	■	■	
ATTAIN HPA	■	■	
CROSS RACE C:62			■
CROSS RACE HPA		■	■
NUROAD HPA	■	■	
SL ROAD	■		

LITENING

The brand new Litening re-writes the race bike rule book. Literally. Completely redesigned to be as aerodynamically efficient as possible, it's the secret weapon you need to break free of the peloton and find your place on the podium. Fast, light and as slippery through the air as a hot knife through butter. Break out and win.

AGREE

Racing isn't just about speed; it's about endurance too. That's where the Agree comes in. Built to be as comfortable as it is ruthlessly efficient, its finely tuned carbon construction is designed to allow you to perform at your best, hour after hour and mile after mile. Because podiums don't come easily.

ATTAIN

Designing a great bike means blending performance with comfort. It's an art that our engineers have perfected with the Attain, which combines the stomp-and-go willingness of a race thoroughbred with the sublime comfort of a ride-all-day grand tourer. Who said you can't have your cake and eat it?

CROSS RACE

A sport for masochists, or a great way to stay ride fit in the off season? Whatever your view of cyclocross, our Cross is the bike you'll want to have underneath you (or on your shoulder). Light, responsive, easy to carry and with clearances designed for muddy courses, it's got your back.

NUROAD

Not all roads are created equal. Some of them are pretty rough, in fact, which is where the Nuroad comes in. Blending cyclocross ruggedness with road bike alacrity, it's the perfect tool for nudging the boundaries and exploring a bit further off the beaten track – without compromising on speed.

SL ROAD

Fast comes in different guises. The SL Road takes the road bike rule book and lobs it into the nearest gutter, because different can also be great. Equipped with flat bars, powerful disc brakes and a responsive, race-derived frame, it's the urban assault speed machine you've been looking for.

FOR us #Racers

A road race bike needs to be fast. That much is obvious, but how to extract more speed from bike and rider? That was the question our engineering team asked themselves at the beginning of the design process for the brand-new Litening. And the answer? Make the frame as slippery as possible through the air. It's a familiar concept for time trial and triathlon bikes, but not so much for race machines. The new Litening re-writes the rules by borrowing from our experience building the standard-setting Aerium C:68. Making extensive use of Computer Fluid Dynamics – backed up with wind tunnel testing at every stage of the design and production process – our engineers were able to finesse the frame's design to realise a 30% reduction in drag. In the world of marginal gains, that's enough to make this a genuine breakaway machine. The fully UCI-compliant chassis design integrates frame, fork, stem, handlebar and seat post into a structure that's as efficient through the air as possible. Beautifully crafted from our next generation C:68X carbon, it's even designed to be minimally affected by crosswinds. The integrated headset features an aero top cap and we were able to reduce the frontal areas of the head tube and fork crown by using disc brakes. It's also highly configurable to suit every race and rider – internal cable routing for Sram and Shimano electronic gears is standard, as is a removable front derailleur mount, and there are multiple bottle positions available. With clearance for tyres up to 28mm and power meter-ready, it's the speed machine you've been looking for to maximise your chances of success. Don't chance it on race day. Ride the Litening – and just go.



LITENING C:68X SLT

379400 carbon'n'blue

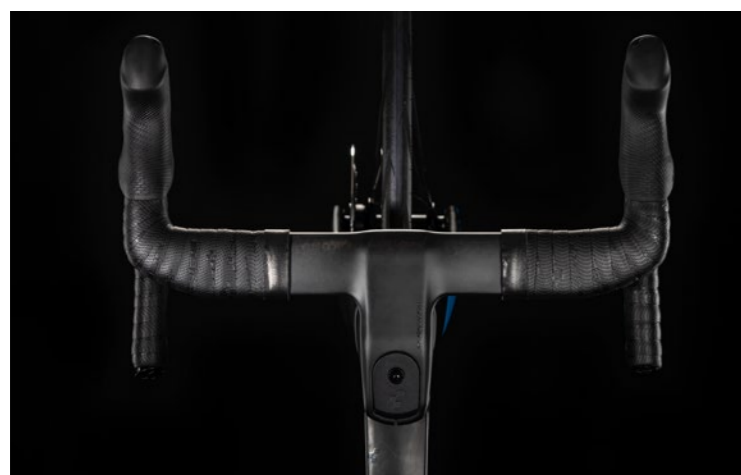



17094
CUBE SHOES RD C:62 SLT

11292
CUBE SLT JERSEY

16127
CUBE HELMET HERON SLT

You've put in the miles, done the hours and measured the results. You're ready to race. Aiming high. Which means you'll need a bike that won't hold you back. Have you met the all-new Litening C:68X SLT? You should, because it's going to redefine your expectations of what's possible from a race bike. As you'd expect from one of our range-topping machines, we've selected only the best components – including Sram's awesome new wireless Red AXS groupset and DT Swiss ARC 1100 DICUT 62 carbon wheelset. But that's only part of the story. Because, building on all the experience gained from developing our wind-cheating Aerium bikes, our engineers used advanced Computer Fluid Dynamics to examine every part of the frame, both individually and collectively, in detail. Then, using the results of these tests, they tested every stage of the development process – from 3D-printed prototype to final production version – in the wind tunnel. The result is a frame that's astonishingly aerodynamically efficient, with 30% lower drag than before thanks to a seamless structure integrating chassis, fork, stem, handlebar and seat post. With minimal cross-wind susceptibility and full UCI approval, it's a race bike that's going to be making waves in pelotons around the world. Clearance for 28mm tyres, power meter compatibility and with provision for multiple bottle positions, it's the not-so-secret weapon that'll give you the advantage you need to break away from the pack.

-  **FRAME** Litening C:68X Monocoque Advanced Twin Mold Technology, Aero Headtube, Full Integrated Cable Routing, Flat Mount Disc
 - SIZE** 50, 52, 54, 56, 58, 60
 - FORK** Litening C:68X Aero, Integrated Cable Routing, Flat Mount Disc
-
-  **HEADSET** CROS, Top Integrated 1 1/8", Bottom Integrated 1 1/4"
 - INTEGRATED BAR/STEM** Litening C:68X ICR Aero Cockpit System, Integrated Cable Routing, Aero Spacer System, Garmin Mount Interface
 - HANDLEBAR TAPE** CUBE Grip Control
 - REAR DERAILLEUR** Sram Red eTap AXS™, 12-Speed
 - FRONT DERAILLEUR** Sram Red eTap AXS™
 - SHIFT/ BRAKE LEVERS** Sram Red eTap AXS™
 - BRAKE SYSTEM** Sram Red eTap AXS™ (160/160)
 - CRANKSET** Sram Red D1, 48x35T, 170mm (50/52cm), 172.5mm (54/56/58cm), 175mm (60cm)
 - CASSETTE** Sram Red XG-1290, 10-28T
 - CHAIN** Sram Red D1
 - WHEELSET** DT Swiss ARC 1100 DICUT Carbon 62
 - TYRES** Schwalbe Pro One, Tubeless Easy, 25-622
 - SADDLE** Fizik Antares R3
 - SEAT POST** Litening C:68X Aero, Comfort Flex
 - SEATCLAMP** CUBE Full Integrated Aero Clamp

 **WEIGHT** 4 kg

-  **SPARE PARTS**
- 8654** CUBE HANGER_mtb/rr-x12-std (18-06267)
- 12819** CUBE Basebar-Stem-Combination Litening C:68X (2020)
- 12821** CUBE Seatpost Litening Setback C:68X (2020)

LITENING C:68X SL

379300 carbon n' red





16129
CUBE HELMET HERON

11015
CUBE BLACKLINE BIB SHORTS

11157
CUBE BLACKLINE JERSEY 2020

A bike so fast it'll make your eyes water sounds like an impossible dream, but that's what we set out to build with the brand-new Litening C:68X SL. You've probably already spotted the Shimano DuraAce Di2 disc groupset and the DT Swiss ARC 1400 DICUT 62 carbon wheelset. They're specially chosen to help you achieve new personal bests, give the competition a hard time and generally raise your game a notch or two. But the secret to the Litening C:68X SL's success is its brand-new aero frame. A full 30% more aerodynamically efficient than before, it makes full use of the all the experience we gained building our record-breaking Aerium bikes. Beginning with a blank sheet of paper and a lot of computer time booked in, the CUBE engineering team set about examining every single part of the frame – individually and collectively – to minimise wind resistance. Computer Fluid Dynamics, backed up by extensive wind tunnel testing, allowed them to refine each iteration until they were happy that they'd created a fully UCI-compliant, ultra-slippery race frame. Details like the disc-specific design and full integration of the frame, fork, stem, handlebar and seat post combine with our next generation C:68X carbon technology to create a new generation of peloton-leading bikes. It's power meter-ready, accepts tyres up to 28mm and offers multiple bottle positions. It is, in short, designed to get out of your way and let you ride. Really, really fast.

-  **FRAME#** Litening C:68X Monocoque Advanced Twin Mold Technology, Aero Headtube, Full Integrated Cable Routing, Flat Mount Disc
- SIZE#** 50, 52, 54, 56, 58, 60
- FORK#** Litening C:68X Aero, Integrated Cable Routing, Flat Mount Disc

-  **HEADSET#** CROS, Top Integrated 1 1/8", Bottom Integrated 1 1/4"
- INTEGRATED BAR/STEM#** Litening C:68X ICR Aero Cockpit System, Integrated Cable Routing, Aero Spacer System, Garmin Mount Interface
- HANDLEBAR TAPE#** CUBE Grip Control
- REAR DERAILLEUR#** Shimano Dura Ace Di2 RD-R9150-DSS, 11-Speed
- FRONT DERAILLEUR#** Shimano Dura Ace Di2 FD-R9150-F, Braze-On
- SHIFT/ BRAKE LEVERS#** Shimano Dura Ace Di2 ST-R9170
- BRAKE SYSTEM#** Shimano Dura Ace BR-R9170, Hydr. Disc Brake, Flat Mount (160/160)
- CRANKSET#** Shimano Dura Ace FC-R9100, 52x36T, 170mm (50/52cm), 172.5mm (54/56/58cm), 175mm (60cm)
- CASSETTE#** Shimano Dura Ace CS-R9100, 11-28T
- CHAIN#** Shimano CN-HG700-11
- WHEELSET#** DT Swiss ARC 1400 DICUT Carbon 62
- TYRES#** Schwalbe Pro One, Tubeless Easy, 25-622
- SADDLE#** Natural Fit Nuance SLT Road
- SEAT POST#** Litening C:68X Aero, Comfort Flex
- SEATCLAMP#** CUBE Full Integrated Aero Clamp

 **WEIGHT#**, 5 kg

-  **SPARE PARTS#**
- 8655** CUBE HANGER_rr-x12-direct-cube
- 12819** CUBE Basebar-Stem-Combination Litening C:68X (2020)
- 12821** CUBE Seatpost Litening Setback C:68X (2020)



Here at CUBE, we never rest on our laurels – and the all-new Litening C:68X Race is proof of that. Completely redesigned from the ground up, it represents our bid to redefine what's possible from a race bike. Knowing that at speeds above around 15km/h aero efficiency is more important than weight, and building on the knowledge we'd gained from building our world-beating Aerium bikes, we set out to create a frame that's not just efficient... but aero-efficient. Sophisticated Computer Fluid Dynamics analysis, backed up by extensive wind tunnel testing, allowed our engineers to optimise every single part of the frame to make it as slippery as possible through the air. Our premium, next-generation C:68X carbon gave them the freedom to sculpt, shape and refine their designs until they were completely happy with the performance. And the result? A seamless structure that integrates the chassis, fork, stem, bar and seat post into a frame that's reduced drag by 30%. Make no mistake, this is game-changing territory. Less drafting, more riding at the front – with power to spare to break away. Fully UCI compliant, we sweated every detail to help you focus on your performance. The low cross-wind effect, integrated headset, clearance for 28mm tyres and lighter head tube and fork crown are all there to ensure you go faster. With Sram's wireless Force AXS 2x12 transmission, Newmen carbon wheelset and Schwalbe's tubeless-compatible tyres, there's nothing to hold you back. Can you sense a podium position in your sights?

-  **FRAME** #Litening C:68X Monocoque Advanced Twin Mold Technology, Aero Headtube, Full Integrated Cable Routing, Flat Mount Disc
- SIZE** #0, 52, 54, 56, 58, 60
- FORK** #Litening C:68X Aero, Integrated Cable Routing, Flat Mount Disc

-  **HEADSET** #CROS, Top Integrated 1 1/8", Bottom Integrated 1 1/4"
- INTEGRATED BAR/STEM** #Litening C:68X ICR Aero Cockpit System, Integrated Cable Routing, Aero Spacer System, Garmin Mount Interface
- HANDLEBAR TAPE** #CUBE Grip Control
- REAR DERAILLEUR** #Sram Force eTap AXS™, 12-Speed
- FRONT DERAILLEUR** #Sram Force eTap AXS™
- SHIFT/ BRAKE LEVERS** #Sram Force eTap AXS™
- BRAKE SYSTEM** #Sram Force eTap AXS™ (160/160)
- CRANKSET** #Sram Force D1, 48x35T, 170mm (50/52cm), 172.5mm (54/56/58cm), 175mm (60cm)
- CASSETTE** #Sram Force XG-1270, 10-33T
- CHAIN** #Sram Force D1
- WHEELSET** #Newmen Advanced SL R.38, Carbon
- TYRES** #Schwalbe Pro One, Tubeless Easy, 25-622
- SADDLE** #Natural Fit Nuance SLT Road
- SEAT POST** #Litening C:68X Aero, Comfort Flex
- SEATCLAMP** #CUBE Full Integrated Aero Clamp

 **WEIGHT** #7 kg

-  **SPARE PARTS**
- 8654** CUBE HANGER_mtb/rr-x12-std (18-06267)
- 12819** CUBE Basebar-Stem-Combination Litening C:68X (2020)
- 12821** CUBE Seatpost Litening Setback C:68X (2020)



10945
CUBE TEAMLINE JACKET REPULSE

11838
CUBE SOCKS HIGH CUT

10940
CUBE TEAMLINE JERSEY

LITENING C:68X PRO

379100 carbon'n'white



With our brand-new Litening C:68X Pro we had a very simple goal: to build the fastest, most aerodynamically efficient race bike with the best materials, so you can take the fight to the front of the peloton. Using the experience we gained from developing our Aerium series, we started with a clean sheet of paper and plenty of time set aside for Computer Fluid Dynamics, backed up by wind tunnel testing at every stage of development. The result is an entirely new approach to building a race bike, with a frame that's 30% more efficient through the air than before. A seamless structure crafted from our premium, next-generation C:68X carbon integrates the chassis, fork, stem, handlebar and seat post to help achieve this remarkable drag reduction – and we've managed to achieve this with low cross-wind effects, too. Fully UCI approved, it's packed full of features to help you maximise your performance. From a choice of bottle positions to power meter compatibility and clearance for 28mm tyres, we've tried to think of everything so that you can just. Go. Shimano's superb Ultegra Di2 disc groupset gives you the slick, precise gear shifting and reliable, fade-free, all-weather brake performance you need to chase the podium results, while tubeless-compatible Schwalbe tyres are fast, grippy and reassuring on any road surface, at any speed. If ever there were a breakaway machine, this is it. It's all you need to put the wind up the competition, pull ahead and break free.

- FRAME#** Litening C:68X Monocoque Advanced Twin Mold Technology, Aero Headtube, Full Integrated Cable Routing, Flat Mount Disc
- SIZE#** 50, 52, 54, 56, 58, 60
- FORK#** Litening C:68X Aero, Integrated Cable Routing, Flat Mount Disc

- HEADSET#** CROS, Top Integrated 1 1/8", Bottom Integrated 1 1/4"
- INTEGRATED BAR/STEM#** Litening C:68X ICR Aero Cockpit System, Integrated Cable Routing, Aero Spacer System, Garmin Mount Interface
- HANDLEBAR TAPE#** CUBE Grip Control
- REAR DERAILLEUR#** Shimano Ultegra Di2 RD-8050-DGS, 11-Speed
- FRONT DERAILLEUR#** Shimano Ultegra Di2 FD-R8050-F
- SHIFT/ BRAKE LEVERS#** Shimano Ultegra Di2 ST-R8070
- BRAKE SYSTEM#** Shimano Ultegra BR-R8070, Hydr. Disc Brake, Flat Mount (160/160)
- CRANKSET#** Shimano Ultegra FC-R8000, Hollowtech II, 50x34T, 170mm (50/52cm), 172.5mm (54/56/58cm), 175mm (60cm)
- CASSETTE#** Shimano Ultegra CS-R8000, 11-32T
- CHAIN#** Shimano CN-HG700-11
- WHEELSET#** Newmen Evolution SL R.32
- TYRES#** Schwalbe Pro One, Tubeless Easy, 25-622
- SADDLE#** Natural Fit Nuance SLT Road
- SEAT POST#** Litening C:68X Aero, Comfort Flex
- SEATCLAMP#** CUBE Full Integrated Aero Clamp

WEIGHT#, 8 kg

- SPARE PARTS#**
- 8455** CUBE HANGER_rr-x12-direct-cube
- 12819** CUBE Basebar-Stem-Combination Litening C:68X (2020)
- 12821** CUBE Seatpost Litening Setback C:68X (2020)

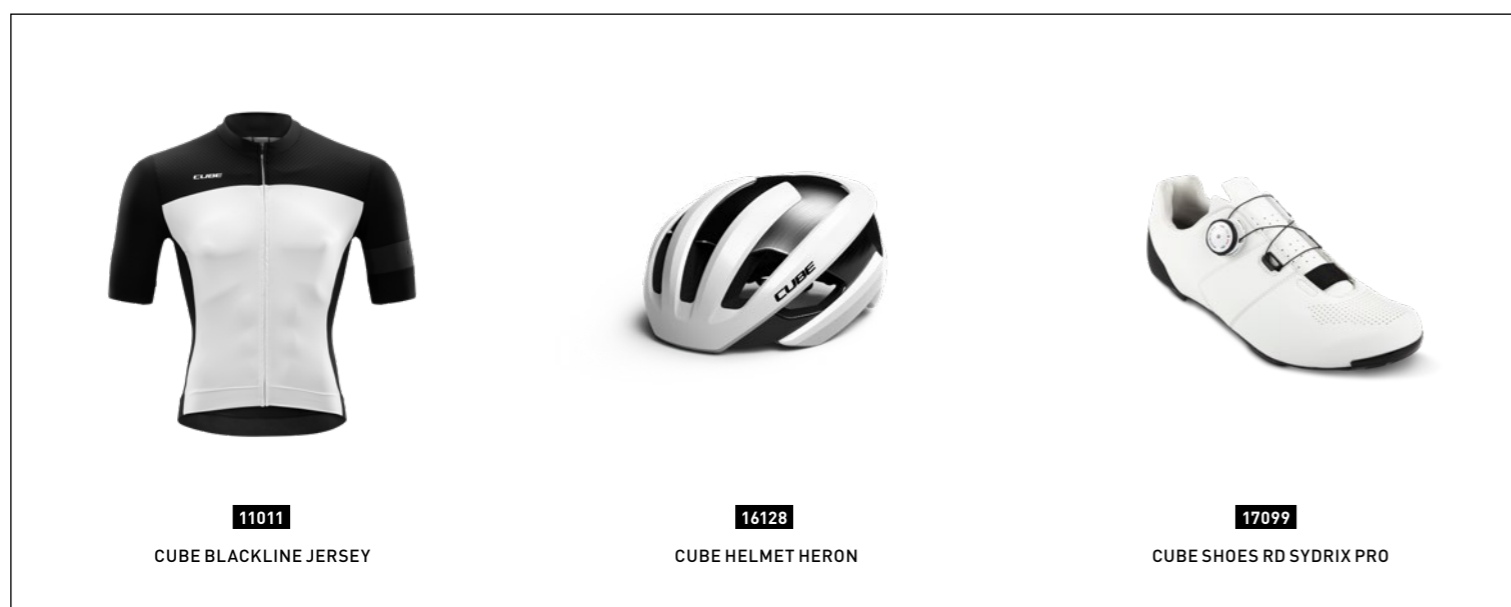

11011
CUBE BLACKLINE JERSEY



16128
CUBE HELMET HERON



17099
CUBE SHOES RD SYDRIX PRO

FOR us #RacePilots

The Agree C:62's superlight race chassis doesn't just look fast; it IS fast. That's because, as with all our bikes, the CUBE design team sweated the details. So, for example, the cutting-edge carbon frame comes complete with a matching CSL Evo carbon fork – and both feature attachment points for Flat Mount brakes to improve the bike's aerodynamics and reduce weight as far as possible. The integrated seat clamp also looks great, but is also another small detail that makes the Agree C:62 more slippery in the air. Meanwhile the PressFit bottom bracket, tapered head tube and carefully profiled down tube and chain stays build into an incredibly rigid structure that converts pedal input into instantaneous forward progress. But we've not forgotten comfort – because a tired rider is a slower rider. Slender seat stays combined with a narrow-diameter seat post and carbon fork blades mean this is a bike that's as comfortable as it is speedy. Comfort AND speed: what more could a rider want?



AGREE C:62 SLT

378400 carbon 'n' black



AGREE C:62 SLT

378410 petrol 'n' red

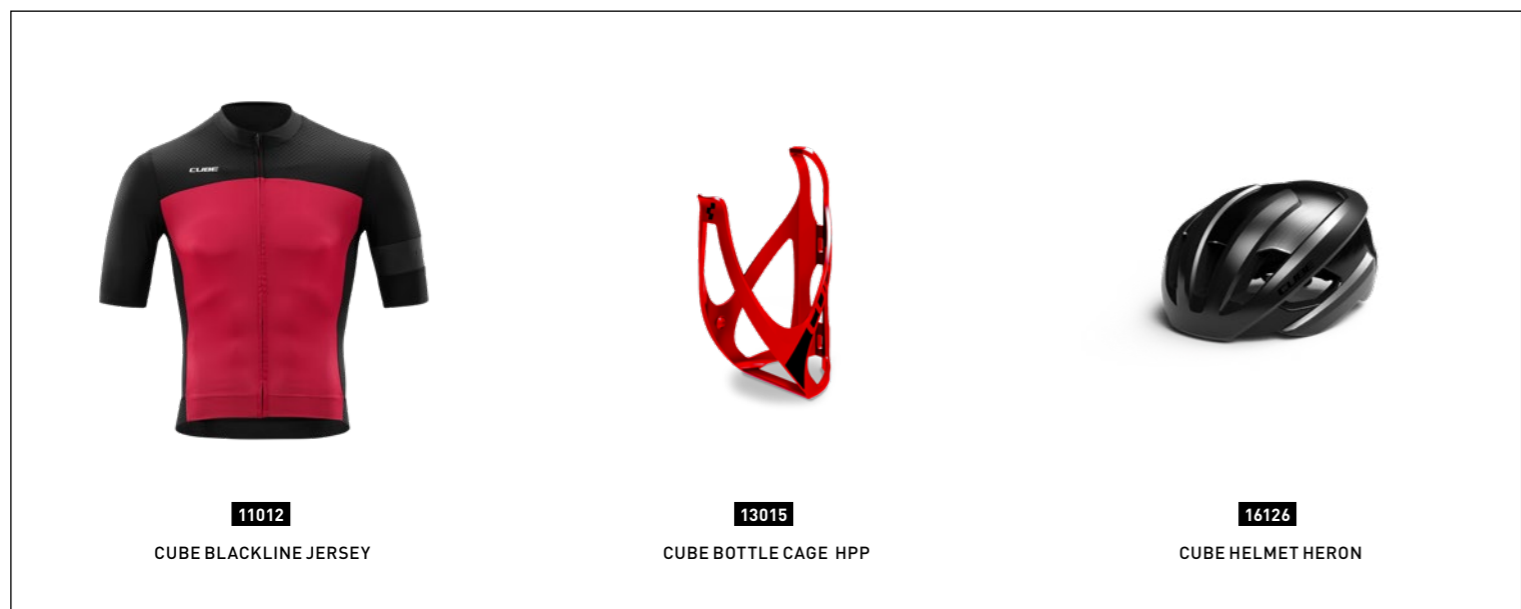

11012
CUBE BLACKLINE JERSEY

13015
CUBE BOTTLE CAGE HPP

16126
CUBE HELMET HERON

Podium places and personal bests don't just happen – they need to be earned. But it's not just about blood, sweat and gears... it's also about having the right bike for the job. That's why we developed the Agree C:62 SLT. It's an uncompromisingly light, stiff, and surprisingly comfortable endurance race bike that will allow any rider to push their limits. Featuring Sram's Force eTap AXS wireless 2x12 transmission with compact chainrings, its seamless gear shifts and wide gear ratio range will help you extract as much speed as possible from your efforts on the pedals. Newmen Advanced SL R.38 aero-carbon wheels and cockpit components seal the competitive edge, and Continental's Grand Prix 5000 tyres grip tenaciously to the road. But the centrepiece of this remarkable bike is, of course, the frame. Front and rear wheels feature 12mm thru-axles for improved stiffness, while the complex-profiled down tube and chain stays build into an incredibly efficient structure. Specially shaped seat stays and carbon fork blades keep the Agree C:62 SLT's rider comfortable for the long haul, and the integrated seat clamp is one of the neat touches that helps improve aerodynamics. See? It's all in the detail. But you already knew that. Which is why, whether you're chasing a personal best or an end-of-season trophy, this is a bike that'll help get you there.

FRAME #62 Advanced Twin Mold Technology Aero Frame, Flat Mount Disc, Road Aero Endurance Geometry, AXH, 12x142mm
SIZE #0, 53, 56, 58, 60, 62
FORK #CUBE CSL Evo Aero C:62 Technology, 1 1/8" / 1 1/4" Tapered, Flat Mount, 12x100mm

HEADSET #FSA I-t, Top Integrated 1 1/8", Bottom Integrated 1 1/4"
STEM #Newmen Evolution 318.4, 31.8mm
HANDLEBAR #Newmen Advanced Wing Bar, Carbon
HANDLEBAR TAPE #CUBE Grip Control
REAR DERAILLEUR #Sram Force eTap AXS™, 12-Speed
FRONT DERAILLEUR #Sram Force eTap AXS™
SHIFT/ BRAKE LEVERS #Sram Force eTap AXS™
BRAKE SYSTEM #Sram Force eTap AXS™ (160/160)
CRANKSET #Sram Force D1, 48x35T, 170mm (50/53cm), 172.5mm (56/58cm), 175mm (60/62cm)
CASSETTE #Sram Force XG-1270, 10-33T
CHAIN #Sram Force D1
WHEELSET #Newmen Advanced SL R.38, Carbon
TYRES #Conti Grand Prix 5000 Kevlar, 25-622
SADDLE #Natural Fit Nuance SLT Road
SEAT POST #Newmen Advanced, Carbon, 27.2mm
SEATCLAMP #CUBE Aero, Semi-Integrated

WEIGHT #7,4 kg

SPARE PARTS
8654 CUBE HANGER_mtb/rr-x12-std (18-06267)
10360 CUBE Headset FSA I-t, Top Integrated 1 1/8", Bottom Integrated 1 1/4"
13553 Inner Tube 28" ROAD SV 60 mm extra light

ROAD RACE

AGREE C:62 SL

378300 carbon 'n' flashyellow



Here at CUBE, a bike has to deserve its SL tag. With race-inspired geometry, a super-stiff carbon chassis that still manages to keep its rider comfortable for long days in the saddle, and a full complement of Shimano's utterly gorgeous Ultegra Di2 components for intuitive shifting and powerful braking, the Agree C:62 SL has earned its place in our race bike line-up. That blend of efficient power transfer and surprising comfort is no accident, either. Our engineers sweated the details so that this is a bike that doesn't just look fast, but IS fast. From the tapered head tube and carefully profiled down tube to the 12mm thru axles, superb torsional rigidity ensures that none of your efforts are wasted. But we've not forgotten comfort, because a tired rider is a slow rider. That's why the carbon fork blades and narrow seat stays are specially designed to filter out performance-robbing vibration. Whether you're mixing it up in the peloton or hammering out the miles on a summer club training ride, the Agree C:62 SL's raison d'être can be summed up neatly in just two words: maximum velocity.

FRAME# C:62 Advanced Twin Mold Technology Aero Frame, Flat Mount Disc, Road Aero Endurance Geometry, AXH, 12x142mm
SIZE# 50, 53, 56, 58, 60, 62
FORK# CUBE CSL Evo Aero C:62 Technology, 1 1/8" / 1 1/4" Tapered, Flat Mount, 12x100mm

HEADSET# SA I-t, Top Integrated 1 1/8", Bottom Integrated 1 1/4"
STEM# Newmen Evolution 318.4, 31.8mm
HANDLEBAR# Newmen Advanced Wing Bar, Carbon
HANDLEBAR TAPE# CUBE Grip Control
REAR DERAILLEUR# Shimano Ultegra Di2 RD-8050-DGS, 11-Speed
FRONT DERAILLEUR# Shimano Ultegra Di2 FD-R8050-F
SHIFT/ BRAKE LEVERS# Shimano Ultegra Di2 ST-R8070
BRAKE SYSTEM# Shimano Ultegra BR-R8070, Hydr. Disc Brake, Flat Mount (160/160)
CRANKSET# Shimano Ultegra FC-R8000, Hollowtech II, 50x34T, 170mm (50/53cm), 172.5mm (56/58cm), 175mm (60/62cm)
CASSETTE# Shimano CS-R7000, 11-32T
CHAIN# Shimano CN-HG600-11
WHEELSET# Ulcrum Racing 77 DB
TYRES# Pirelli Grand Sport Race SL, 28-622
SADDLE# Selle Royal Asphalt
SEAT POST# Newmen Advanced, Carbon, 27.2mm
SEATCLAMP# CUBE Aero, Semi-Integrated

WEIGHT#,9 kg

SPARE PARTS#
8655 CUBE HANGER_rr-x12-direct-cube
10360 CUBE Headset FSA I-t, Top Integrated 1 1/8", Bottom Integrated 1 1/4"
13553 Inner Tube 28" ROAD SV 60 mm extra light

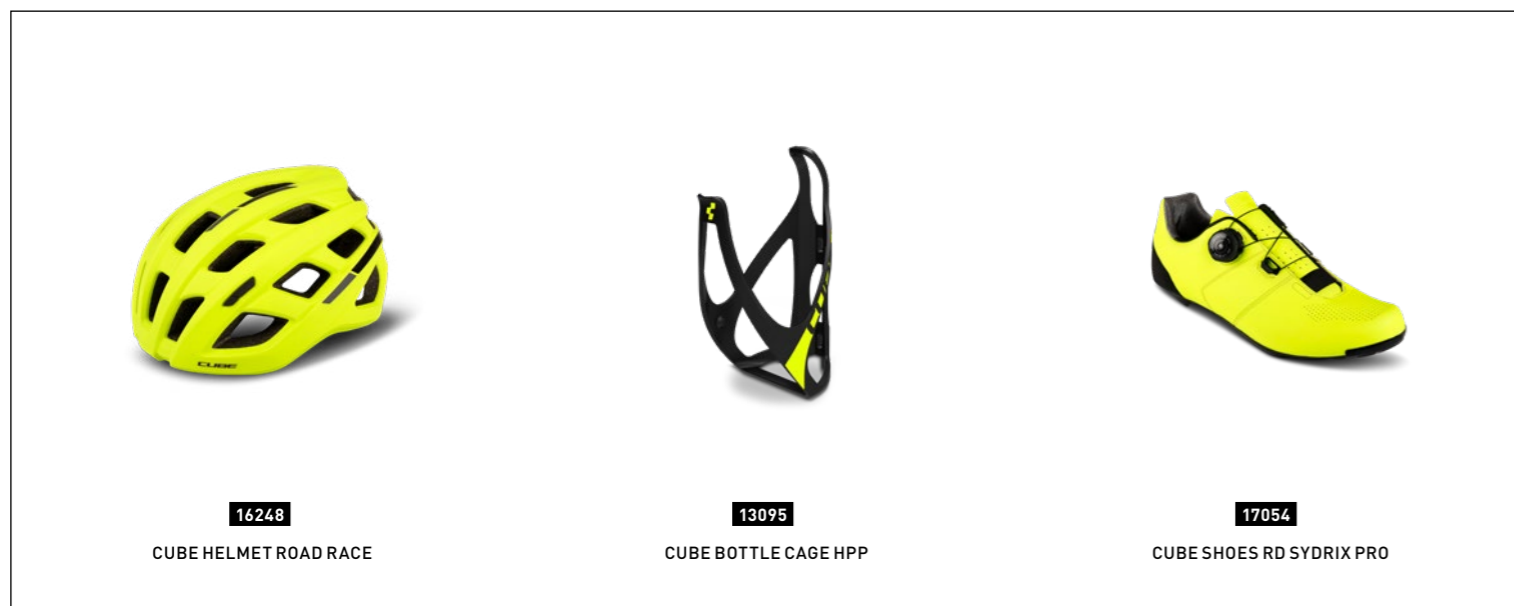

16248
CUBE HELMET ROAD RACE

13095
CUBE BOTTLE CAGE HPP

17054
CUBE SHOES RD SYDRIX PRO

AGREE C:62 RACE

378200 carbon 'n' white



AGREE C:62 RACE

378210 bluegrey 'n' orange



Turn up to a race or a training ride with the Agree C:62 Race and it's fair to say that you've run out of excuses. But then again, you've also got a thoroughbred race machine on your side. With a full Newmen cockpit setup, Shimano's extraordinary Ultegra gears and hydraulic disc brakes and a light, stiff and strong Newmen Evolution SL R.32 wheelset, this is an endurance speed machine that will bring out the best in every rider. The tapered head tube and 12mm thru axles work together with the oversized down tube to deliver razor-sharp handling and incredible drivetrain efficiency, whilst slender seat stays and carbon fork blades are designed to help reduce rider fatigue on even the roughest of road surfaces. Whether it's a tough climb – where the Agree C:62 Race's low weight and exceptional power delivery come to the fore – or long, fast descents – where the fade-free power of the hydraulic disc brakes and agile geometry work together to ensure you're always in full control – you're onto a winner. This is a cutting-edge carbon frame that's equipped to perform. All that's missing is you.

FRAME #CUBE Agree C:62 Advanced Twin Mold Technology Aero Frame, Flat Mount Disc, Road Aero Endurance Geometry, AXH, 12x142mm
SIZE #0, 53, 56, 58, 60, 62
FORK #CUBE CSL Evo Aero C:62 Technology, 1 1/8" / 1 1/4" Tapered, Flat Mount, 12x100mm

HEADSET #SA I-t, Top Integrated 1 1/8", Bottom Integrated 1 1/4"
STEM #Newmen Evolution 318.4, 31.8mm
HANDLEBAR #Newmen Advanced Wing Bar, Carbon
HANDLEBAR TAPE #CUBE Grip Control
REAR DERAILLEUR #Shimano Ultegra RD-R8000-DGS, 11-Speed
FRONT DERAILLEUR #Shimano Ultegra FD-R8000-F
SHIFT/ BRAKE LEVERS #Shimano Ultegra ST-R8020
BRAKE SYSTEM #Shimano Ultegra BR-R8070, Hydr. Disc Brake, Flat Mount (160/160)
CRANKSET #Shimano Ultegra FC-R8000, Hollowtech II, 50x34T, 170mm (50/53cm), 172.5mm (56/58cm), 175mm (60/62cm)
CASSETTE #Shimano Ultegra CS-R8000, 11-32T
CHAIN #Shimano CN-HG700-11
WHEELSET #Newmen Evolution SL R.32
TYRES #Pirelli Grand Sport Race SL, 28-622
SADDLE #Selle Royal Asphalt
SEAT POST #Newmen Advanced, Carbon, 27.2mm
SEATCLAMP #CUBE Aero, Semi-Integrated

WEIGHT #2,2 kg

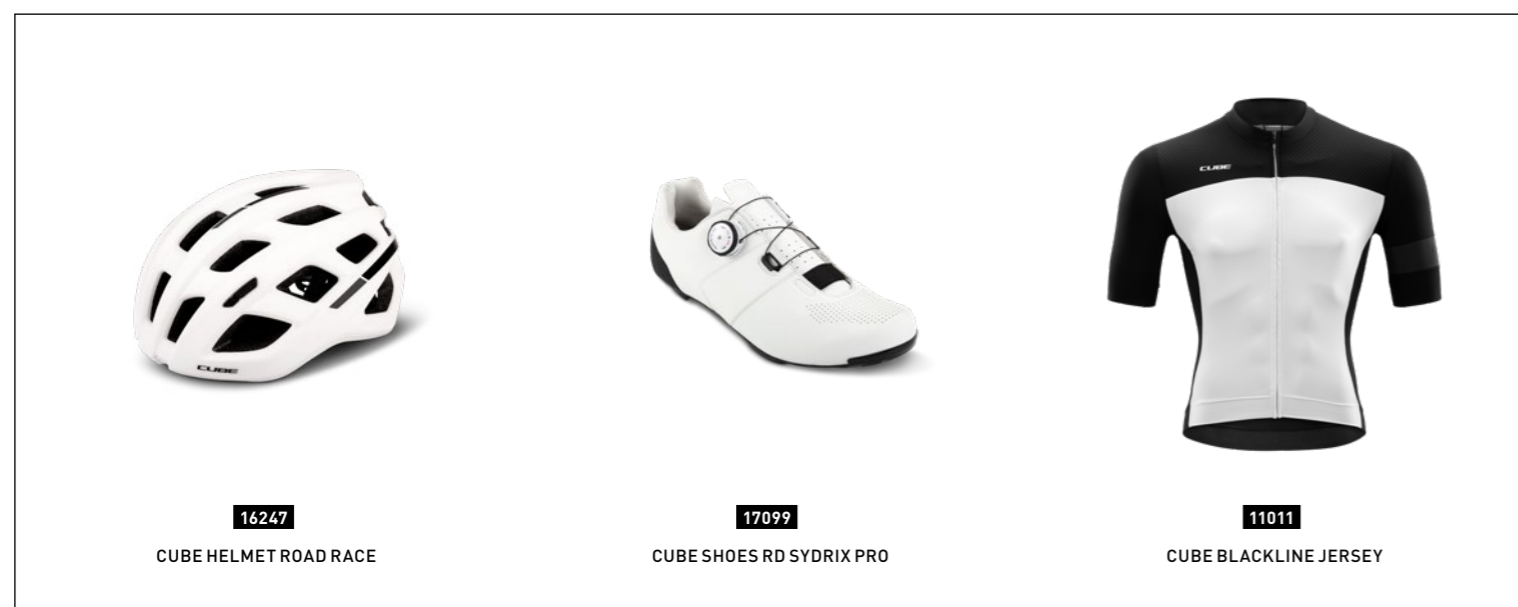

16247
CUBE HELMET ROAD RACE

17099
CUBE SHOES RD SYDRIX PRO

11011
CUBE BLACKLINE JERSEY

SPARE PARTS
8655 CUBE HANGER_rr-x12-direct-cube
10360 CUBE Headset FSA I-t, Top Integrated 1 1/8", Bottom Integrated 1 1/4"
33041 CUBE Bar Tape Carbon

FOR us #Roadies

The Attain GTC's frame was developed from the ground up by our engineers to combine class-leading comfort, performance and low weight for endurance riding. The beauty of carbon construction is that, with the right expertise, practically anything is possible. So, for example, the rear end's slim aero Flex Stays are designed to reduce the impact of road shocks on the rider – a clear advantage on longer rides, increasing comfort and reducing the symptoms of fatigue and tension. The big-volume down tube, combined with the PressFit bottom bracket and tapered head tube, ensures that the rider's efforts are efficiently converted into forward propulsion, and that every steering impulse is precisely transmitted to the front wheel. As you'd expect, we maintained the frame's elegant looks by routing cables internally, which also has the benefit of keeping gear shifts cleaner for longer. And less maintenance means more time riding...



ATTAIN GTC SL

377300 carbon 'n' white



ATTAIN GTC SL

377310 red 'n' orange

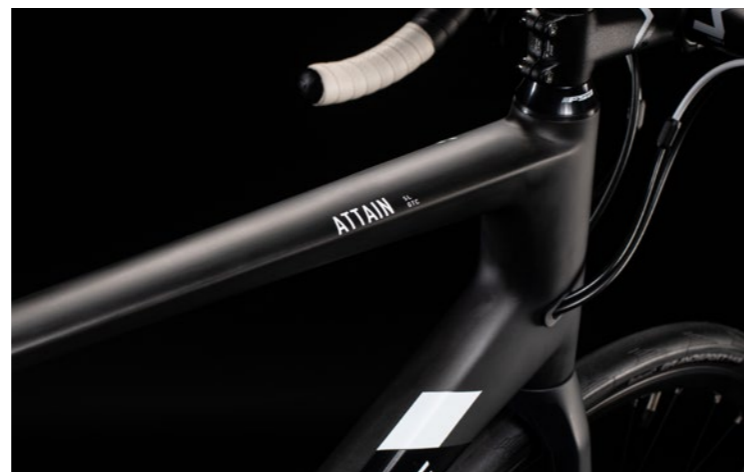
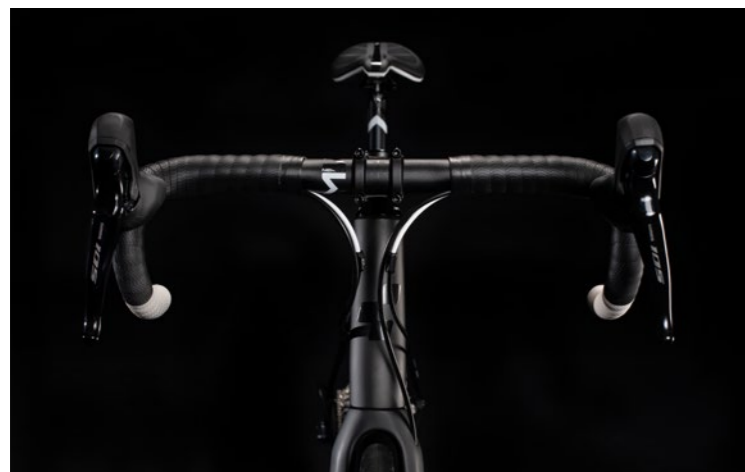

The Attain GTC SL is a masterpiece of both aesthetics and function, even if we do say so ourselves. A high-performance race bike in its own right, it combines the sublime comfort of a high-tech carbon frame with the speed-enhancing safety of the latest in disc brake technology. The ultimate high-speed endurance machine? We like to think so. Shimano's peerless Ultegra gears, compact and elegant 105 disc brakes and a Fulcrum Racing 77 wheelset blend the taut, elegant and surprisingly comfortable carbon frame to make a consummate long-distance mile-muncher. Carbon fork blades and deliberately slender seat stays help filter out harsh vibrations from rough road surfaces, while 12mm axles front and rear combined with a tapered head tube and cross-ovalised down tube ensure that all your effort goes into propelling you forward – and that the powerful brakes can bring you quickly and safely to a stop, whatever the weather. Efficiency, comfort and performance: it's all in the Attain GTC SL's genes.

FRAME #CUBE Monocoque Twin Mold Technology, Flat Mount Disc, Road Comfort Geometry, AXH, 12x142mm
SIZE #0, 53, 56, 58, 60, 62
FORK #CUBE CSL Race Disc, Full Carbon, Flat Mount, 1 1/8" - 1 1/4" Tapered, 12x100mm

HEADSET #SA I-t, Top Integrated 1 1/8", Bottom Integrated 1 1/4"
STEM #Newmen Evolution 318.4, 31.8mm
HANDLEBAR #Newmen Evolution Wing Bar
HANDLEBAR TAPE #CUBE Grip Control
REAR DERAILLEUR #Shimano Ultegra RD-R8000-DGS, 11-Speed
FRONT DERAILLEUR #Shimano Ultegra FD-R8000-BM, 31.8mm Clamp
SHIFT/ BRAKE LEVERS #Shimano 105 ST-R7020
BRAKE SYSTEM #Shimano 105 BR-R7070, Hydr. Disc Brake, Flat Mount (160/160)
CRANKSET #Shimano Ultegra FC-R8000, Hollowtech II, 50x34T, 170mm (50/53cml), 172.5mm (56/58cml), 175mm (60/62cml)
CASSETTE #Shimano CS-R7000, 11-32T
CHAIN #Shimano CN-HG600-11
WHEELSET #Fulcrum Racing 77 DB
TYRES #Pirelli Grand Sport Race SL, 28-622
SADDLE #Natural Fit Nuance Lite
SEAT POST #Newmen Evolution, 27.2mm
SEATCLAMP #CUBE Screwlock, 31.8mm

WEIGHT #,6 kg

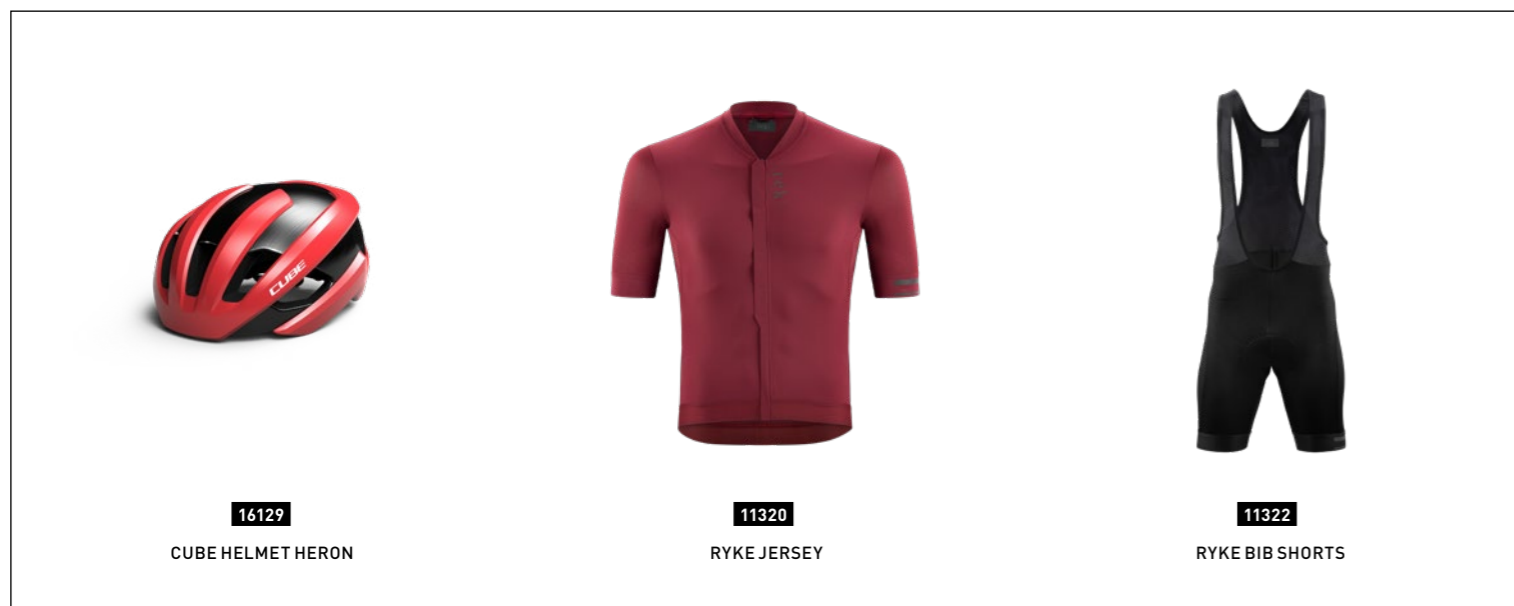

16129
CUBE HELMET HERON

11320
RYKE JERSEY

11322
RYKE BIB SHORTS

SPARE PARTS
13777 CUBE Cubeguard Attain Disc
8655 CUBE HANGER_rr-x12-direct-cube
10360 CUBE Headset FSA I-t, Top Integrated 1 1/8", Bottom Integrated 1 1/4"



ROAD RACE

ATTAIN GTC RACE

377200 carbon'n'flashyellow



We designed the Attain GTC Race to be as comfortable as it is fast. That's why it features aero Flex Stays and a full carbon fork – to make the best possible use of carbon's natural vibration-damping qualities to improve rider comfort. But speed is important for a race bike, too, so we ensured that the tapered head tube and large cross-section down tube give the frame the torsional rigidity it needs for every watt of your pedal input to be translated into forward progress. Shimano's superb 105 transmission delivers slick, reliable gear shifts mile after mile, helped by the internally routed cables and their resistance to water and dirt ingress. And powerful hydraulic disc brakes ensure that you have all the control and stopping power you need on even the longest mountain descents, whatever the weather decides to throw at you. With CUBE finishing components it all adds up to a package that's pure-bred racing snake, built to take on anything from a sportive to an epic hilly ride with your training buddies.

-  **FRAME** #CUBE Monocoque Twin Mold Technology, Road Comfort Geometry
 - SIZE** #0, 53, 56, 58, 60, 62
 - FORK** #CUBE CSL Race, Full Carbon, 1 1/8"-1 1/4" Tapered
-
-  **HEADSET** #FSA I-t, Top Integrated 1 1/8", Bottom Integrated 1 1/4"
 - STEM** #CUBE Performance Stem Pro, 31.8mm
 - HANDLEBAR** #CUBE Compact Race Bar
 - HANDLEBAR TAPE** #CUBE Grip Control
 - REAR DERAILLEUR** #Shimano 105 RD-R7000-DGS, 11-Speed
 - FRONT DERAILLEUR** #Shimano 105 FD-R7000, 31.8mm Clamp
 - SHIFT/ BRAKE LEVERS** #Shimano 105 ST-R7020
 - BRAKE SYSTEM** #Shimano 105 BR-R7070, Hydr. Disc Brake, Flat Mount [160/160]
 - CRANKSET** #Shimano FC-R5510, 50x34T, 170mm [50/53cm], 172.5mm [56/58cm], 175mm [60/62cm]
 - CASSETTE** #Shimano CS-R7000, 11-32T
 - CHAIN** #Shimano CN-HG600-11
 - WHEELSET** #CUBE RA 0.8 Aero Disc
 - TYRES** #Conti Grand Sport Race SL, 28-622
 - SADDLE** #Natural Fit Nuance Lite
 - SEAT POST** #CUBE Performance Post, 27.2mm
 - SEATCLAMP** #CUBE Screwlock, 31.8mm

 **WEIGHT** #, 2 kg

-  **SPARE PARTS**
- 8655** CUBE HANGER_rr-x12-direct-cube
- 10360** CUBE Headset FSA I-t, Top Integrated 1 1/8", Bottom Integrated 1 1/4"
- 13554** Inner Tube 28" ROAD SV 40 mm extra light

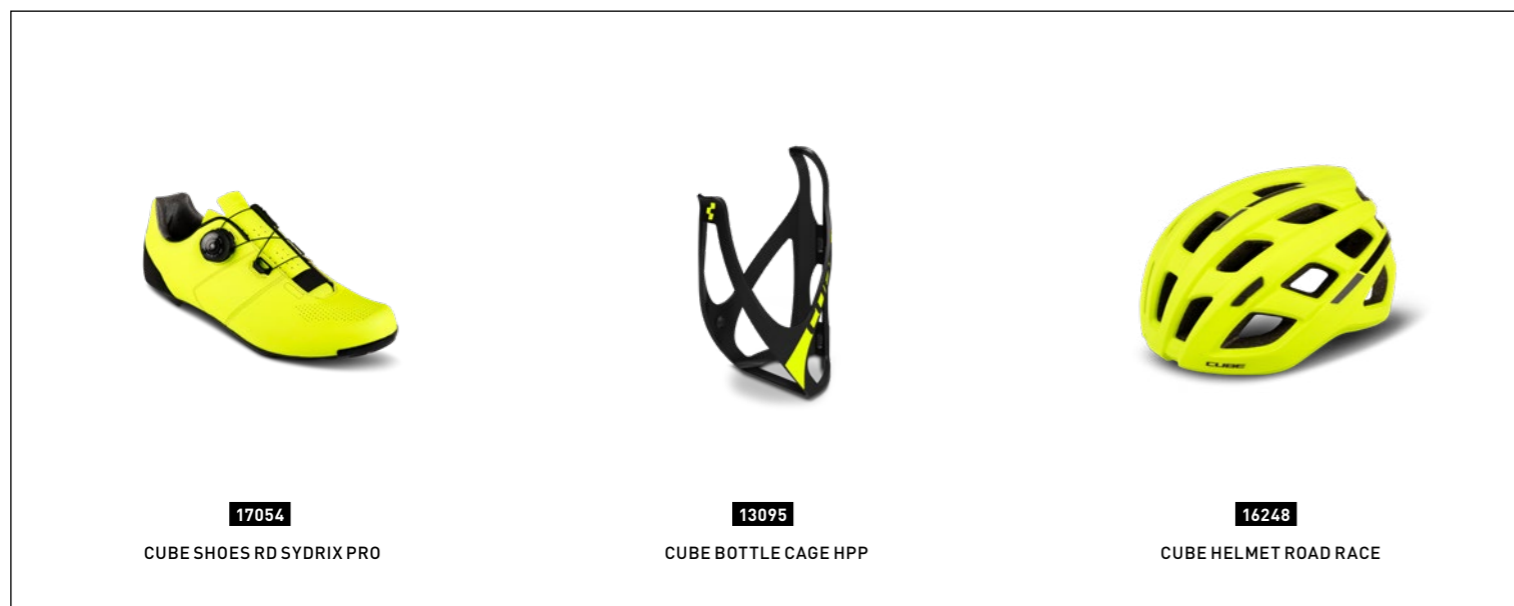

17054
CUBE SHOES RD SYDRIX PRO

13095
CUBE BOTTLE CAGE HPP

16248
CUBE HELMET ROAD RACE

FOR us #Cyclists

You shouldn't need to suffer for your sport. It's a mantra that keeps our engineering team busy, building in more comfort and better control for every frame. The Attain's Superlite 6061 aluminium chassis is no exception. Double-buttressed tubes reduce weight wherever possible whilst maintaining the strength for which all CUBE's frames are renowned – and which we prove every day in our in-house test lab. Smooth Welding gives the frame an organic appearance, one tube seeming to flow into the next. And internal cable routing keeps gears shifting cleanly and brakes working smoothly, through all weathers. But it's not all about looks. The tapered steerer and mechanically formed down tube provide a rigid backbone for efficient power delivery and accurate steering, while slender seat stays and a full carbon fork reduce road shock and vibration for significantly improved rider comfort, even on rough roads and long rides. Because we're all about speed... but comfort is important too.



ROAD RACE

ATTAIN SL

376400 black 'n' grey



ATTAIN SL

376410 bluegrey 'n' green

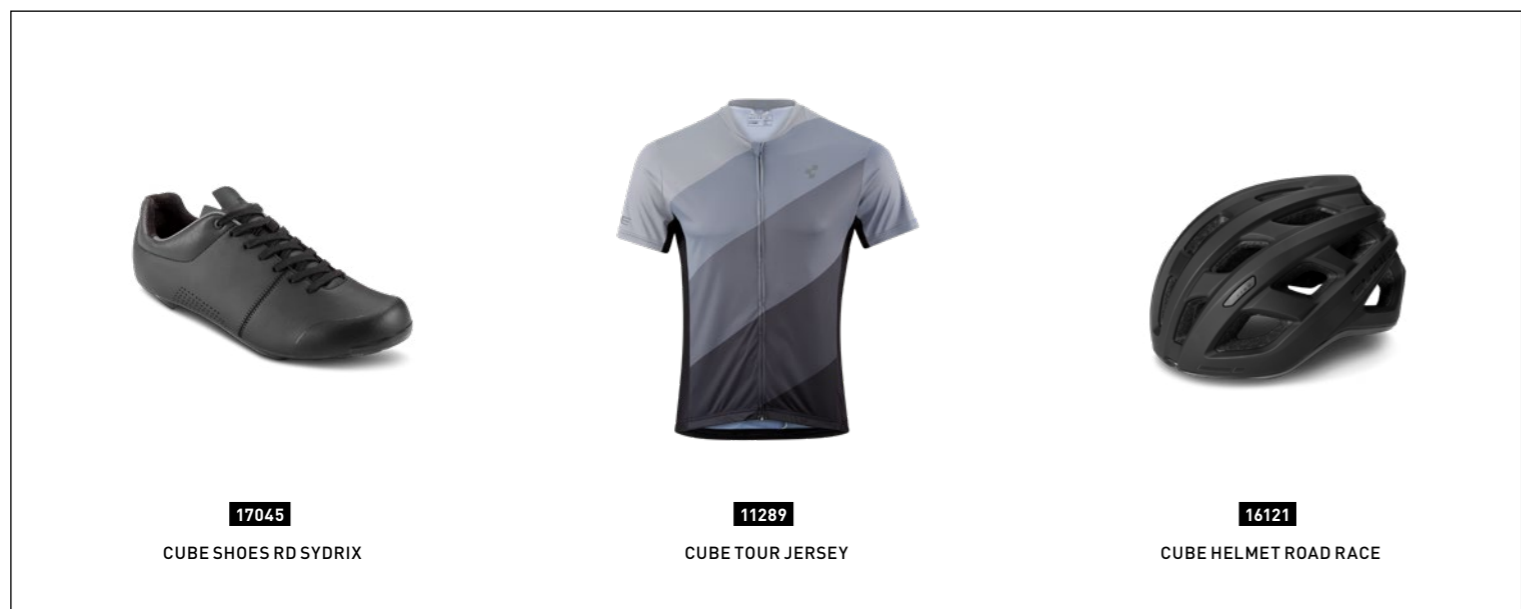

17045
CUBE SHOES RD SYDRIX



11289
CUBE TOUR JERSEY



16121
CUBE HELMET ROAD RACE

Our Attain series is known for its beguiling blend of comfort and pace. But speed is nothing without control, so for the Attain SL we went the whole way and specced hydraulic disc brakes for the ultimate in all-weather stopping power. With smooth, predictable braking at your fingertips no descent is too fast, too steep or too long for this road thoroughbred. Thanks to Shimano's legendary 105 2x11 groupset, you also have an exceptional range of gears just a click or two away. But great components are only half the story, because the Attain SL's frame is also a masterpiece in its own right. From the stiffness-enhancing 12mm rear axle, tapered head tube and cross-ovalised down tube to the comfort-boosting narrow seat stays and full carbon fork, our engineering team sweated the details so that you can concentrate on racking up the miles. Internal cable routing, mudguard mounts and plenty of clearance for 28c tyres add up to a bike that's built to keep riding all year round. The only question is, are you up for it?

FRAME Aluminium 6061 T6 Superlite, Double Butted, Smooth Welded, 3D Flat Mount Disc Brake Dropouts, Road Comfort Geometry, Fender Option, 12x142mm
SIZE 50, 53, 56, 58, 60, 62
FORK CUBE CSL Race Disc, Full Carbon, 1 1/8" - 1 1/4" Tapered, Flat Mount, 12x100mm

HEADSET SA Z-t, Top Zero-Stack 1 1/8" (OD 44mm), Bottom Integrated 1 1/4"
STEM CUBE Performance Stem Pro, 31.8mm
HANDLEBAR CUBE Compact Race Bar
HANDLEBAR TAPE CUBE Grip Control
REAR DERAILLEUR Shimano 105 RD-R7000-DGS, 11-Speed
FRONT DERAILLEUR Shimano 105 FD-R7000, 31.8mm Clamp
SHIFT/ BRAKE LEVERS Shimano 105 ST-R7020
BRAKE SYSTEM Shimano 105 BR-R7070, Hydr. Disc Brake, Flat Mount (160/160)
CRANKSET Shimano FC-R5510, 50x34T, 170mm (50/53cm), 172.5mm (56/58cm), 175mm (60/62cm)
CASSETTE Shimano 105 CS-HG700, 11-34T
CHAIN Shimano CN-HG600-11
WHEELSET CUBE RA 0.8 Aero Disc
TYRES Conti Ultra Sport 2, 28-622
SADDLE Natural Fit Nuance Lite
SEAT POST CUBE Performance Post, 27.2mm
SEATCLAMP CUBE Screwlock, 31.8mm

WEIGHT 7,6 kg

SPARE PARTS#
8655 CUBE HANGER_rr-x12-direct-cube
10359 CUBE Headset FSA Z-t, Top Zero-Stack 1 1/8" (OD 44mm)
13777 CUBE Cubeguard Attain Disc

ATTAIN RACE

376300 black 'n' white



ATTAIN RACE

376310 blue 'n' red

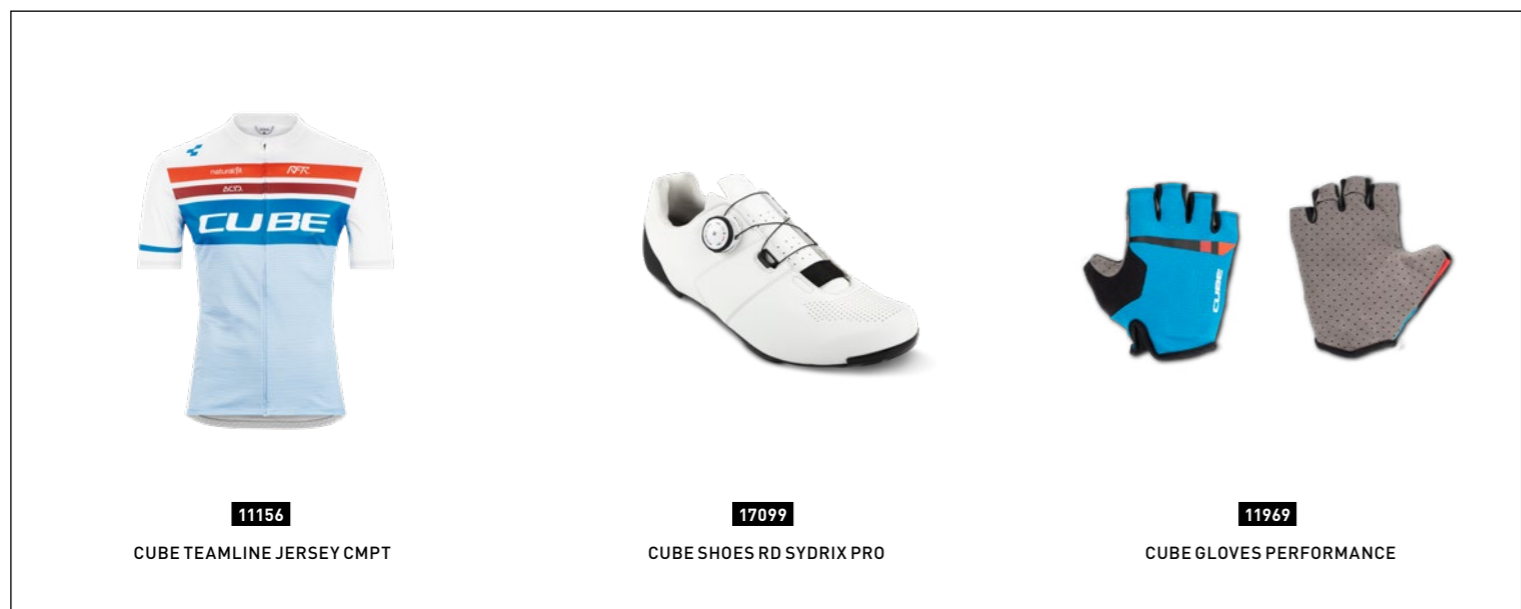

11156
CUBE TEAMLINE JERSEY CMPT

17099
CUBE SHOES RD SYDRIX PRO

11969
CUBE GLOVES PERFORMANCE

Speed can be addictive – and all the more so when it's achieved under your own power. The Attain Race has all the attributes of a fast road bike – nimble handling, efficient power delivery and a great selection of reliable components – with the added comfort of a frame that's designed with longer rides in mind. Shimano's 2x10-speed Tiagra gears put the right ratio for any road literally at your fingertips, while powerful mechanical disc brakes offer the peace of mind of consistent, controllable braking in any weather conditions. Our engineers carefully finessed the profile of every frame tube to arrive at the ideal blend of efficient power transfer, intuitive handling and surprising comfort, even on rough roads. You can thank features like the slim, flat seat stays and large-diameter, cross-ovalised down tube for that. And the full carbon fork adds even more to the comfortable ride, while subtracting a healthy chunk of weight. We know the whole lot is safe and durable, because we've tested it in our own 24/7 test lab. All that's left for you to do is to figure out where you're going to ride next. Ride solo or ride with your mates... this is a bike that'll have you coming back for more.

FRAME# Aluminium 6061 T6 Superlite, Double Butted, Smooth Welded, 3D Flat Mount Disc Brake Dropouts, Road Comfort Geometry, Fender Option, 12x142mm
SIZE# 50, 53, 56, 58, 60, 62
FORK# CUBE CSL Race Disc, Full Carbon, 1 1/8" - 1 1/4" Tapered, Flat Mount, 12x100mm

HEADSET# SA Z-t, Top Zero-Stack 1 1/8" (OD 44mm), Bottom Integrated 1 1/4"
STEM# CUBE Performance Stem Pro, 31.8mm
HANDLEBAR# CUBE Compact Race Bar
HANDLEBAR TAPE# CUBE Grip Control
REAR DERAILLEUR# Shimano Tiagra RD-4700GS, 10-Speed
FRONT DERAILLEUR# Shimano Tiagra FD-4700, 31.8mm Clamp
SHIFT/ BRAKE LEVERS# Shimano Tiagra ST-4700
BRAKE SYSTEM# RP Spyre MD-C610C, Flat Mount (160/160)
CRANKSET# Shimano Tiagra FC-4700, 50x34T, 170mm (50/53cm), 172.5mm (56/58cm), 175mm (60/62cm)
CASSETTE# Shimano CS-HG500, 11-34T
CHAIN# MC X10
WHEELSET# CUBE RA 0.8 Aero Disc
TYRES# Conti Ultra Sport 2, 28-622
SADDLE# Natural Fit Nuance Lite
SEAT POST# CUBE Performance Post, 27.2mm
SEATCLAMP# CUBE Screwlock, 31.8mm

WEIGHT# 8 kg

SPARE PARTS#
8654 CUBE HANGER_mtb/rr-x12-std (18-06267)
10359 CUBE Headset FSA Z-t, Top Zero-Stack 1 1/8" (OD 44mm)
13777 CUBE Cubeguard Attain Disc

ROAD RACE

ATTAIN PRO

376200 black'n'orange

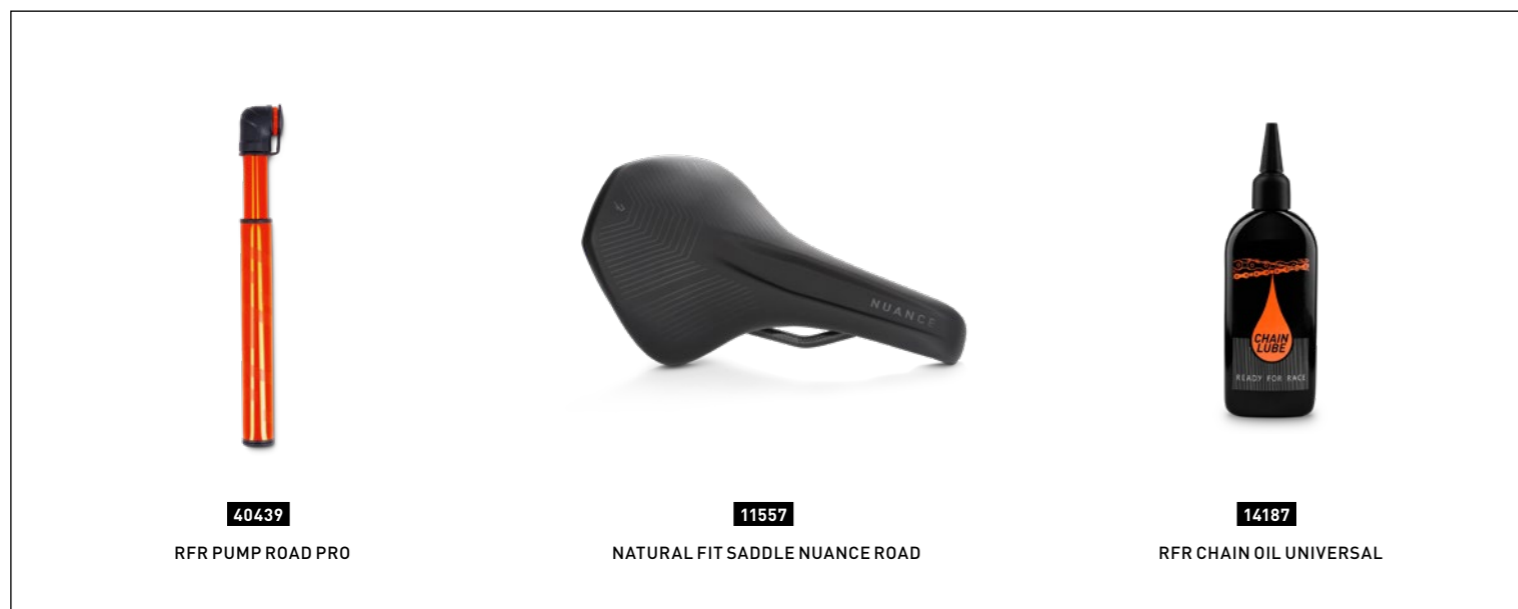
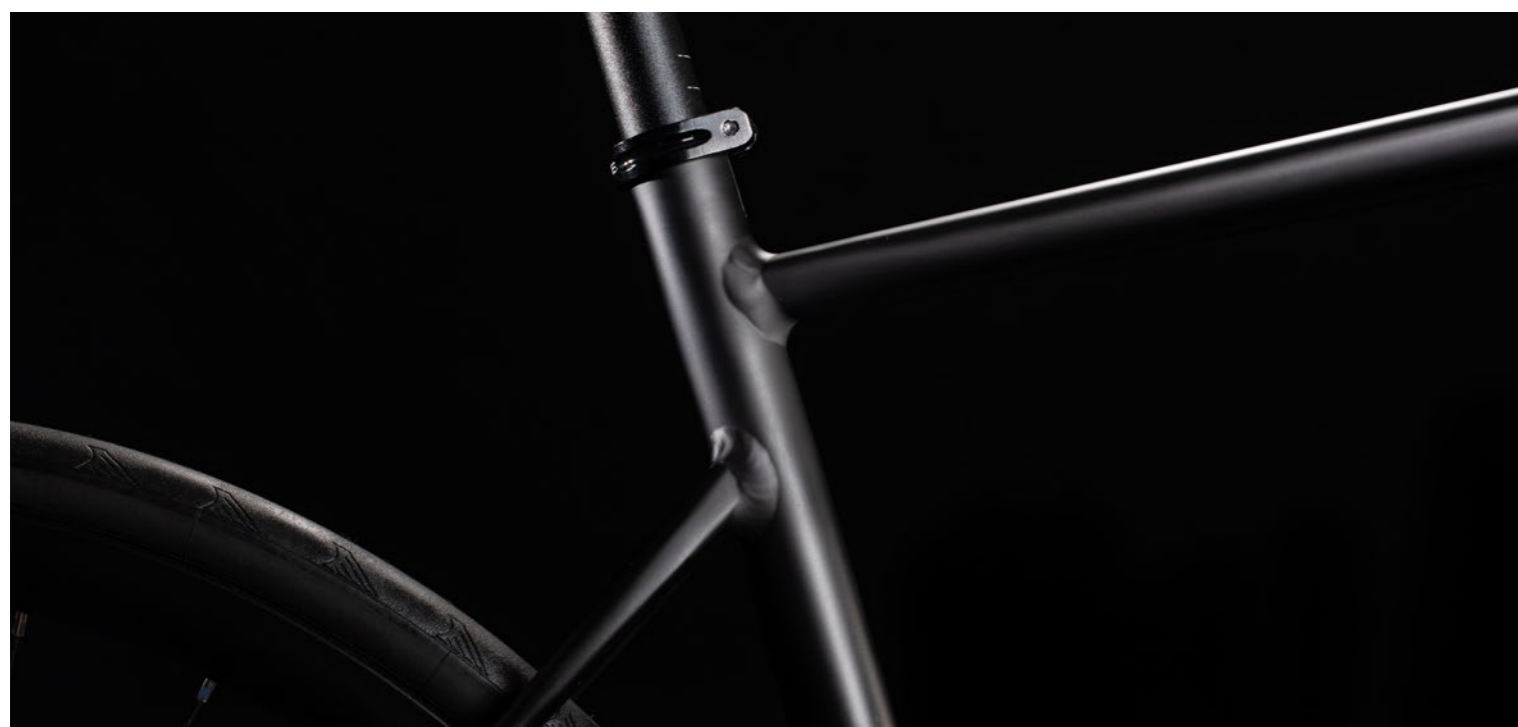

40439
RFR PUMP ROAD PRO

11557
NATURAL FIT SADDLE NUANCE ROAD

14187
RFR CHAIN OIL UNIVERSAL



Comfort, lively handling and the reassurance of safe, powerful braking in any weather conditions – that's the promise of our understated, affordable and versatile Attain Pro. From the cable-actuated Tektro disc brakes to the 2x9 Shimano Sora transmission, it takes its inspiration from the race bikes used by the pros but adds a dose of real-world comfort and practicality. And that's important, because it means you don't need to be a racer to get the best from it. The frame has been designed to blend comfort and pace, using features like 12mm axles and a tapered head tube for stiffness and slender seat stays for enhanced ride comfort on rough surfaces. Joining the dots is our Road Comfort Geometry, which does exactly what it says on the tin to keep you happily churning out the miles for as long as you want to. The result of all this fastidious attention to detail is a bike that'll make every ride a pleasure, whether it's a shorter training blast or a longer weekend route with your riding buddies. It's all the bike you'll ever need to get the best out of your ride time.

FRAME# Aluminium 6061 T6 Superlite, Double Butted, Smooth Welded, 3D Flat Mount Disc Brake Dropouts, Road Comfort Geometry, Fender Option, 12x142mm
SIZE# 7, 50, 53, 56, 58, 60, 62
FORK# CUBE CSL Race Disc, Full Carbon, 1 1/8" - 1 1/4" Tapered, Flat Mount, 12x100mm

HEADSET# SA Z-t, Top Zero-Stack 1 1/8" (OD 44mm), Bottom Integrated 1 1/4"
STEM# CUBE Performance Stem Pro, 31.8mm
HANDLEBAR# Cube Compact Race Bar
HANDLEBAR TAPE# CUBE Grip Control
REAR DERAILLEUR# Shimano Sora RD-R3000, 9-Speed
FRONT DERAILLEUR# Shimano Sora FD-R3000-BM, 31.8mm Clamp
SHIFT/ BRAKE LEVERS# Shimano Sora ST-R3000
BRAKE SYSTEM# RP Spyre MD-C610C, Flat Mount (160/160)
CRANKSET# Shimano Sora FC-R3000, 9-Speed, 50x34T, 165mm (47cm), 170mm (50/53/56cm), 175mm (58/60/62cm)
CASSETTE# Shimano CS-HG200, 11-34T
CHAIN# KMC X9
WHEELSET# CUBE RA 0.8 Aero Disc
TYRES# Conti Ultra Sport 2, 28-622
SADDLE# Natural Fit Venec Lite
SEAT POST# CUBE Performance Post, 27.2mm
SEATCLAMP# CUBE Screwlock, 31.8mm

WEIGHT# 9 kg

SPARE PARTS#
8654 CUBE HANGER_mtb/rr-x12-std (18-06267)
10359 CUBE Headset FSA Z-t, Top Zero-Stack 1 1/8" (OD 44mm)
13777 CUBE Cubeguard Attain Disc

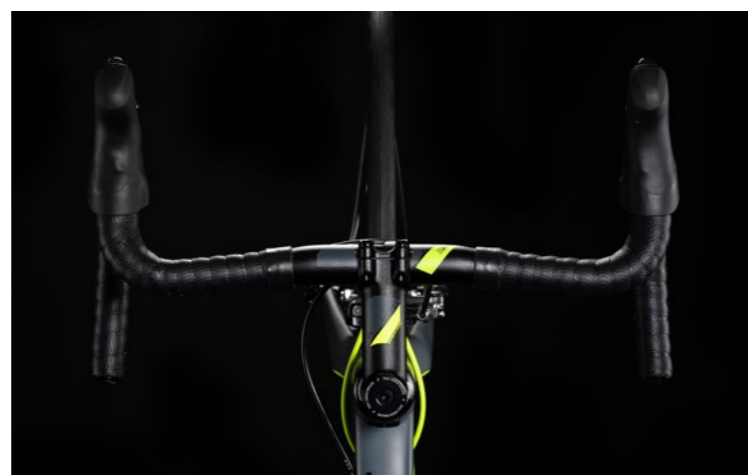

When the open road calls, you'll want a bike that blends comfort and pace with easy handling. The Attain is our affordable introduction to the world of road riding and the allure of simple, unadulterated human-powered speed. We combined proven technology and years of experience designing aluminium road bikes with a carefully curated selection of reliable components, so you can just concentrate on enjoying the ride. Shimano's slick-shifting, smooth-braking Claris 2x8 components and grippy Continental tyres ensure you're all set to take on any road. Features like the slim, cross-ovalised seat stays – which help improve comfort on poor road surfaces – and the tapered head tube – which enhances steering precision – are typical of the attention to detail that does into every CUBE frame. And our Road Comfort Geometry is designed to make racking up the miles as comfortable and effortless as possible, allowing you to ride further and for longer. Where will your Attain take you?

-  **FRAME#**Aluminium 6061 T6 Superlite, Road Comfort Geometry
- SIZE#**7, 50, 53, 56, 58, 60, 62
- FORK#**CUBE CSL Race, Full Carbon, 1 1/8"-1 1/4" Tapered

-  **HEADSET#**SA Z-t, Top Zero-Stack 1 1/8" (OD 44mm), Bottom Integrated 1 1/4"
- STEM#**CUBE Performance Stem Pro, 31.8mm
- HANDLEBAR#**CUBE Compact Race Bar
- HANDLEBAR TAPE#**CUBE Grip Control
- REAR DERAILLEUR#**Shimano Claris RD-R2000-GS, 8-Speed
- FRONT DERAILLEUR#**Shimano Claris FD-R2000-BM, 31.8mm Clamp
- SHIFT/ BRAKE LEVERS#**Shimano Claris ST-R2000
- BRAKE SYSTEM#**Shimano Claris BR-R2000
- CRANKSET#**Shimano Claris FC-R2000, 50x34T, BB-RS500, 165mm (47cm), 170mm (50/53/56cm), 175mm (58/60/62cm)
- CASSETTE#**Shimano CS-HG31, 11-34T
- CHAIN#**MC Z7
- WHEELSET#**CUBE RA 0.8 Aero, QR/QR
- TYRES#**Conti Ultra Sport 2, 25-622
- SADDLE#**Natural Fit Venec Lite
- SEAT POST#**CUBE Performance Post, 27.2mm
- SEATCLAMP#**CUBE Screwlock, 31.8mm

 **WEIGHT#**,6 kg

-  **SPARE PARTS#**
- 10151** CUBE Hanger #151 for Attain/Agree MY2016
- 10359** CUBE Headset FSA Z-t, Top Zero-Stack 1 1/8" (OD 44mm)
- 13551** Inner Tube 28" ROAD SV 40 mm



16248
CUBE HELMET ROAD RACE



93332
ACID BOTTLE CAGE HPP



13363
RFR CHAIN COMBINATION LOCK STYLE CMPT

FOR us #Cyclocrossers

Light, lighter, lightest. When saving every gramme is the goal, every single detail matters. We knew that choosing our premium C:62 carbon was a good start, but the Cross Race C:62 needed something special to set it apart. The answer came from an unusual direction: our engineering team decided to route cables internally via the head tube, rather than the usual down tube routing. This approach fulfilled two goals. First, it created an incredibly clean look and eliminated any cable rub. And second, it meant we didn't need to reinforce the down tube to the same extent as usual, saving even more weight. Internal cable routing uses custom inserts which can be swapped out easily, so you can run electronic, wireless or traditional cable-actuated gears. Combined with the full carbon fork and race-bred geometry designed for quick, precise handling, the Cross Race C:62 is proof that the devil really is in the detail.



CROSS RACE C:62 SLT

388600 bluegrey'n'orange

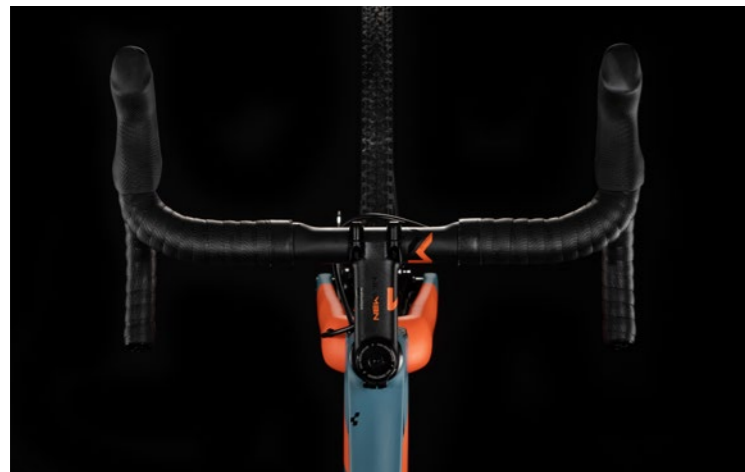

You'll know when cyclocross has really got to you, because you won't be able to wait until the weekend comes around again. The Cross Race C:62 SLT was developed for cyclocross aficionados with mud running through their veins: ultralight, perfectly formed and equipped with the simple goal of winning in mind. Built with our premium C:62 carbon, our engineers sweated the details to save weight wherever possible. So, for example, they removed the need to reinforce the down tube by routing cables straight into the head tube. Not only does this shave precious grammes, it also eliminates cable rub and makes shouldering and running with the bike quicker and easier. Combined with the full carbon fork, geometry that's all about razor-sharp handling on the race course and a full selection of race-worthy components, the result is little short of astonishing. Sram's wireless Force AXS 1x12 groupset offers mud-proof gear-shifting precision, an incredible range of ratios and assured, predictable stopping via hydraulic disc brakes. Light, stiff and strong Newmen Advanced wheels shod with grippy Schwalbe tyres cut through mud for the best possible drive and control, while Newmen Advanced carbon cockpit components are the perfect match for the frame's impeccable credentials. Indulge your winning streak – race the Cross Race C:62 SLT.

FRAME #CUBE C:62 Advanced Twin Mold Technology, Internal Cable Routing, Flat Mount Disc, 12x142mm, AXH
SIZE #0, 53, 56, 58, 61
FORK #CUBE Cross Race Disc C:62 Technology, 1 1/8" - 1 1/2" Tapered, Flat Mount Disc

HEADSET #SA Orbit Z-t, Top Zero-Stack 1 1/8" (OD44mm), Bottom Integrated 1 1/2"
STEM #Newmen Evolution 318.4, 31.8mm
HANDLEBAR #Newmen Advanced Wing Bar, Carbon
HANDLEBAR TAPE #CUBE Grip Control
REAR DERAILLEUR #Sram Force eTap AXS™, 12-Speed
SHIFT/ BRAKE LEVERS #Sram Force eTap AXS™
BRAKE SYSTEM #Sram Force eTap AXS™ (160/160)
CRANKSET #Sram Force D1 38T, 170mm (50/53cm), 172.5mm (56cm), 175mm (58/61cm)
CASSETTE #Sram Force XG-1270, 10-33T
CHAIN #Sram Force D1
WHEELSET #Newmen Advanced SL R.38, Carbon
FRONT TIRE #Schwalbe X-One Bite, Kevlar, 33-622
REAR TIRE #Schwalbe X-One Allround, Kevlar, 33-622
SADDLE #Natural Fit Nuance SLT Road
SEAT POST #Newmen Advanced, Carbon, 27.2mm
SEATCLAMP #CUBE Aero, Semi-Integrated

WEIGHT #7 kg



11568

NATURAL FIT SADDLE VENECLITE X ACTIONTEAM



14027

CUBE COMPUTER RACE PEAK



13022



CUBE BOTTLE CAGE HPP

SPARE PARTS
8654 CUBE HANGER_mtb/rr-x12-std (18-06267)
10325 CUBE Headset Orbit Z-t + 1 1/8 crown race
33041 CUBE Bar Tape Carbon





Cyclocross can be brutal. At CUBE we understand this only too well – it's the reason we developed the Cross Race C:62 SL. Featuring a full carbon chassis – complete with cyclocross-specific carbon fork – and a component setup geared for hard use on the race circuit, it's got the low weight, exceptional efficiency and brilliant handling you'll need to stay out front on race day. Internal cable routing via the head tube eliminates cable rub and, combined with the curved seat stay / top tube junction, makes shouldering easier, quicker and more comfortable. Race-bred geometry provides sharp, nimble handling and our premium C:62 builds into a light, exceptionally stiff and responsive frame that you'd expect of a thoroughbred racer. To keep things simple, we chose Shimano's new 1x11 transmission and fitted a custom chain guide, so you don't have to worry about an unshipped chain ruining your day during the rough and tumble of racing. The 11-40T cassette provides a huge gear range, transferring power to the light, stiff Newmen Evolution wheelset and grippy Schwalbe X-One tyres, and Shimano hydraulic discs ensure you can control your speed through the worst that the elements and race course can throw at you. With Newmen Advanced carbon cockpit components shaving even more weight, it's a package that's shouting out to be ridden hard. Now all you need to do is pedal, run and pedal your way to the podium...

-  **FRAME** #CUBE C:62 Advanced Twin Mold Technology, Internal Cable Routing, Flat Mount Disc, 12x142mm, AXH
 - SIZE** #0, 53, 56, 58, 61
 - FORK** #CUBE Cross Race Disc C:62 Technology, 1 1/8" - 1 1/2" Tapered, Flat Mount Disc
-
-  **HEADSET** #SA Orbit Z-t, Top Zero-Stack 1 1/8" (OD44mm), Bottom Integrated 1 1/2"
 - STEM** #Newmen Evolution 318.4, 31.8mm
 - HANDLEBAR** #Newmen Advanced Wing Bar, Carbon
 - HANDLEBAR TAPE** #CUBE Grip Control
 - REAR DERAILLEUR** #Shimano GRX RD-RX812, Direct Mount, 11-Speed
 - SHIFT/ BRAKE LEVERS** #Shimano GRX ST-RX810
 - BRAKE SYSTEM** #Shimano BR-RX810, Hydr. Disc Brake, Flat Mount (160/160)
 - CRANKSET** #Easton EC90SL Carbon 1X 40T, 170mm (50cm), 172.5mm (53/56cm), 175mm (58/61cm)
 - CASSETTE** #Shimano CS-M8000, 11-40T
 - CHAIN** #Shimano CN-HG700-11
 - WHEELSET** #Newmen Evolution SL R.32
 - TYRES** #Schwalbe X-One Allround, Kevlar, 35-622
 - SADDLE** #Natural Fit Nuance Lite
 - SEAT POST** #Newmen Advanced, Carbon, 27.2mm
 - SEATCLAMP** #CUBE Aero, Semi-Integrated

 **WEIGHT** #,2 kg

-  **SPARE PARTS#**
- 8655** CUBE HANGER_rr-x12-direct-cube
- 10325** CUBE Headset Orbit Z-t + 1 1/8 crown race
- 33041** CUBE Bar Tape Carbon

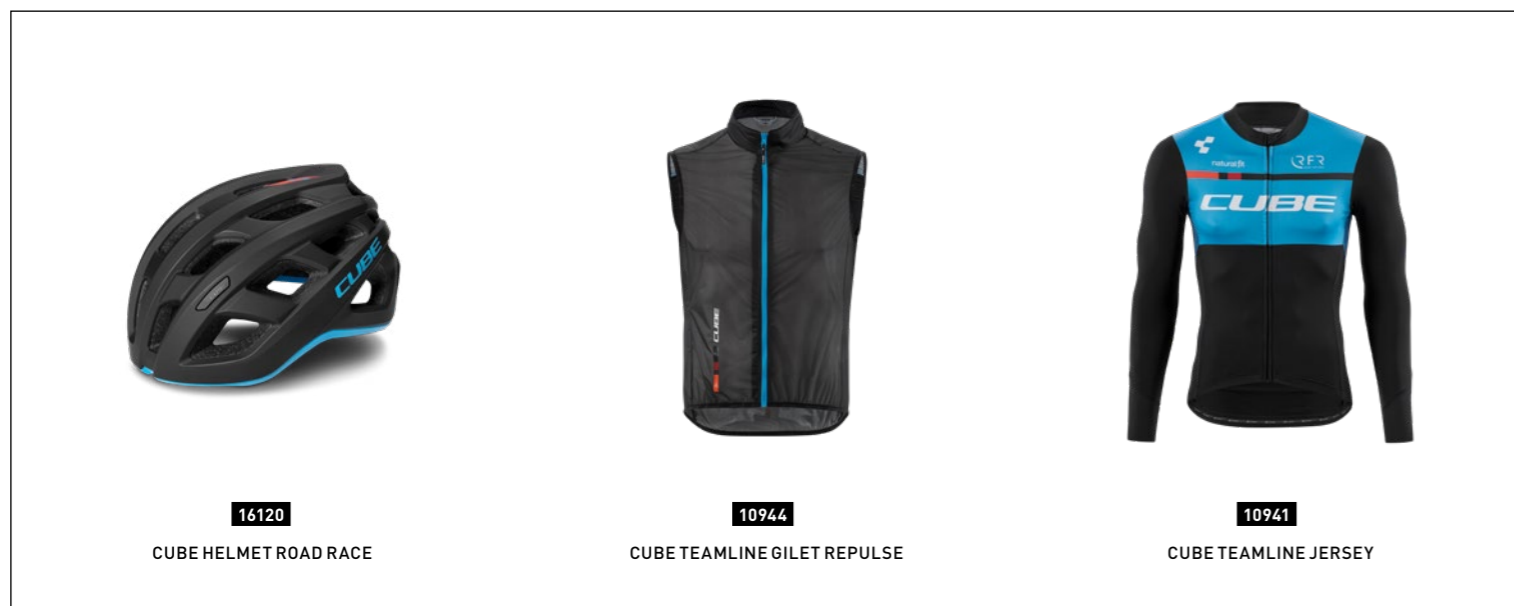

16120
CUBE HELMET ROAD RACE

10944
CUBE TEAMLINE GILET REPULSE

10941
CUBE TEAMLINE JERSEY

CROSS RACE C:62 PRO

388400 carbon'n'green



Got the .cross racing bug? This is the bike to fuel your passion: the Cross Race C:62 Pro. A sleek, carbon-framed race bike designed to excel in the muddy hell of competitive cyclocross, it's full of clever details to make your life that little bit easier out on the race course. For example, racers love internal cable routing for its ability to keep gear shifts reliably slick through the filthiest of conditions. But what, our engineers wondered, if the cables were routed directly into the head tube? The answer is in front of you: a super-clean look, absolutely no cable rub, lower weight – because the down tube doesn't need to be reinforced to accept cable holes – and shorter cables for less interference with shouldering the bike. Speaking of which, the curved seat stays and top tube junction makes that particular task a little less uncomfortable. And our premium C:62 carbon makes for a light, stiff and nimble chassis that'll be with you for every step and pedal revolution. We even added changeable inserts for a future upgrade to electronic shifting – although you'll love the reliable performance of Shimano's legendary Ultegra groupset. Fulcrum Racing 77 wheels are light and strong, Schwalbe X-One tyres grip tenaciously in the mud and a Newmen Evolution cockpit keeps you firmly in control. It's all designed to help you cut through both the mud and the competition. So don't get cross, get the Cross Race C:62 Pro instead.

FRAME #CUBE C:62 Advanced Twin Mold Technology, Internal Cable Routing, Flat Mount Disc, 12x142mm, AXH
SIZE #0, 53, 56, 58, 61
FORK #CUBE Cross Race Disc C:62 Technology, 1 1/8" - 1 1/2" Tapered, Flat Mount Disc

HEADSET #SA Orbit Z-t, Top Zero-Stack 1 1/8" (OD44mm), Bottom Integrated 1 1/2"
STEM #Newmen Evolution 318.4, 31.8mm
HANDLEBAR #Newmen Evolution Wing Bar
HANDLEBAR TAPE #CUBE Grip control
REAR DERAILLEUR #Shimano Ultegra RD-RX800-DGS, 11-Speed
FRONT DERAILLEUR #Shimano Ultegra FD-R8000-F
SHIFT/ BRAKE LEVERS #Shimano Ultegra ST-R8020
BRAKE SYSTEM #Shimano Ultegra BR-R8070, Hydr. Disc Brake, Flat Mount (160/160)
CRANKSET #Shimano Ultegra FC-R8000, 11-Speed, 46x36T, 170mm (50cm), 172.5mm (53/56cm), 175mm (58/61cm)
CASSETTE #Shimano CS-R7000, 11-32T
CHAIN #Shimano CN-HG600-11
WHEELSET #Fulcrum Racing 77 DB
FRONT TIRE #Schwalbe X-One Bite, Kevlar, 33-622
REAR TIRE #Schwalbe X-One Allround, Kevlar, 33-622
SADDLE #Natural Fit Nuance Lite
SEAT POST #Newmen Evolution, 27.2mm
SEATCLAMP #CUBE Aero, Semi-Integrated

WEIGHT #7 kg

SPARE PARTS#
8655 CUBE HANGER_rr-x12-direct-cube
10325 CUBE Headset Orbit Z-t + 1 1/8 crown race
13550 Inner Tube 28" TREKKING SV 40 mm



33040
CUBE BAR TAPE CORK



13019
CUBE BOTTLE CAGE HPP



12971
CUBE BOTTLE FEATHER 0.75L



CROSS RACE SL

388300 bluegrey'n'orange

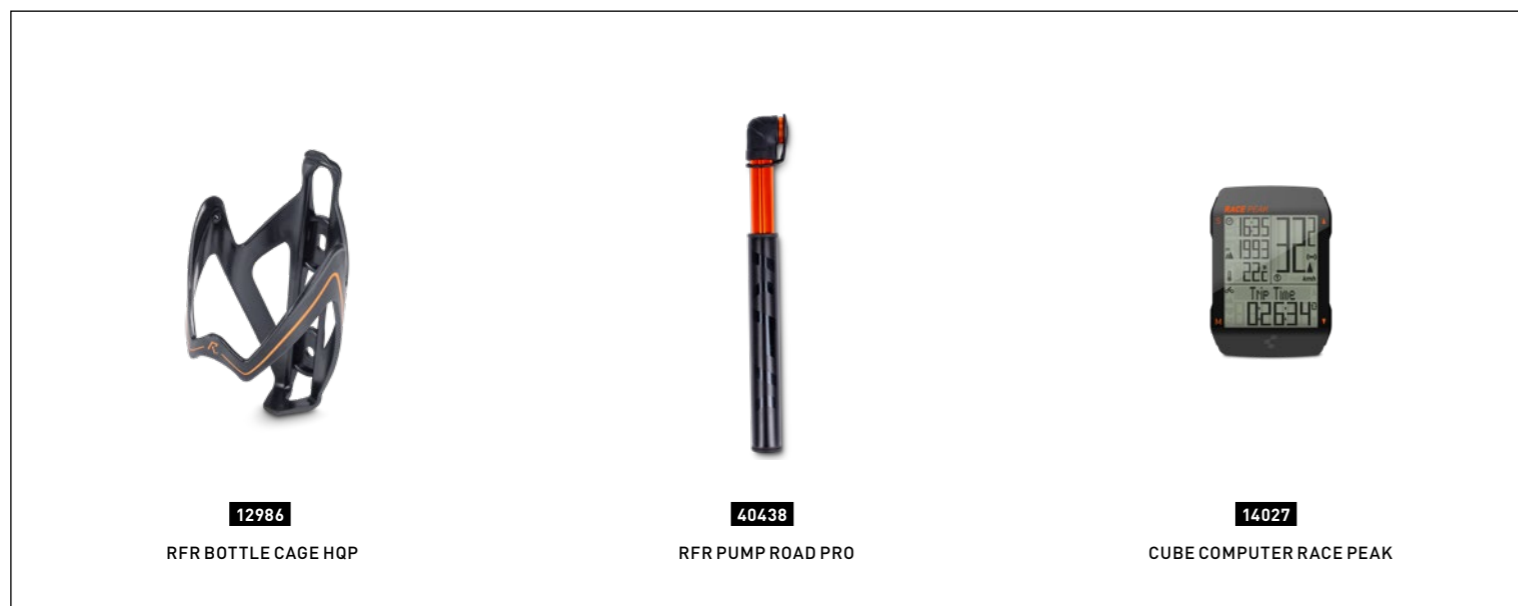
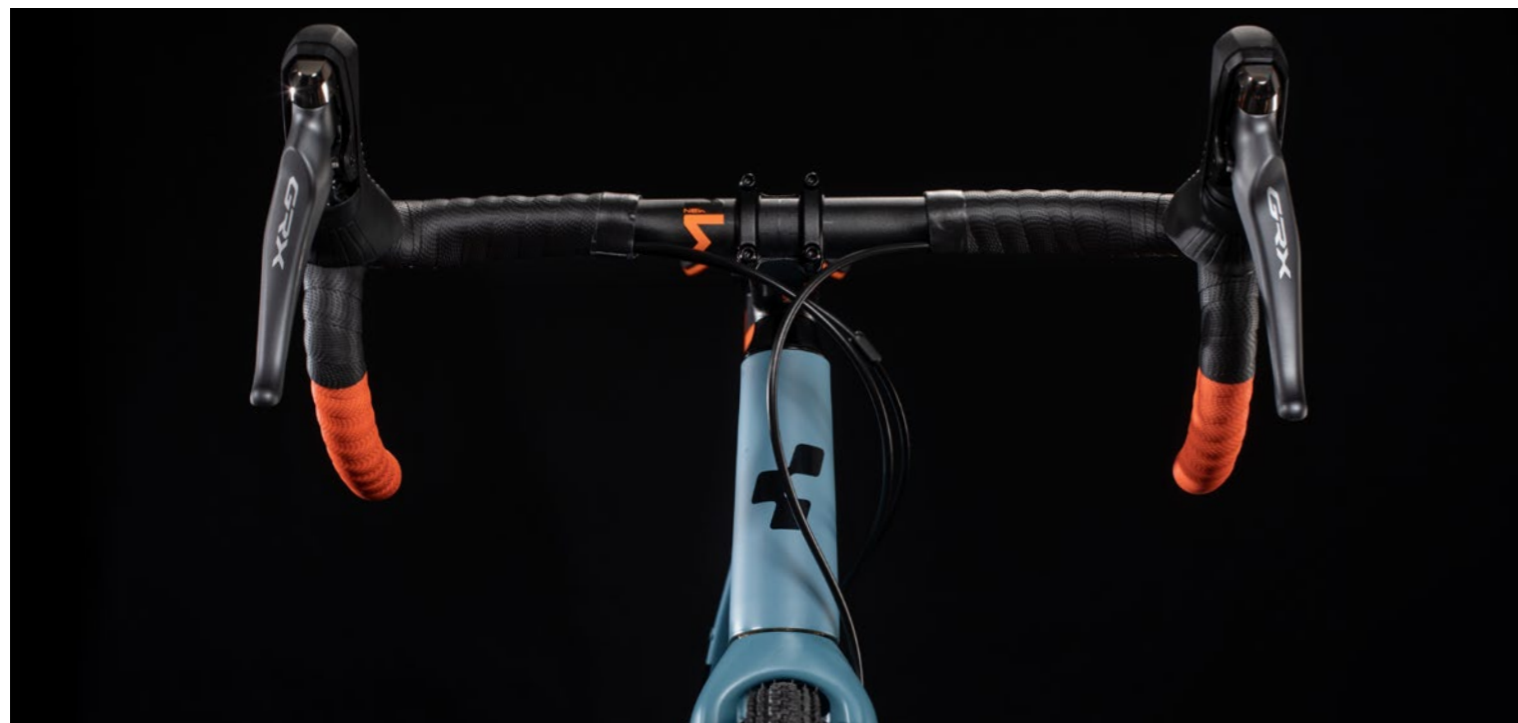

12986
RFR BOTTLE CAGE HQP

40438
RFR PUMP ROAD PRO

14027
CUBE COMPUTER RACE PEAK



The competition had better be ready for this. Our high-end cyclocross race machine is as subtly understated as it is uncompromisingly rapid – truly, a wolf in sheep's clothing. We've thrown all our aluminium frame-building expertise at the Cross Race SL, added a cyclocross-specific carbon fork and then fitted Shimano's new cyclocross-ready GRX 1x11 groupset with wide-ranging cassette and powerful hydraulic disc brakes. Our advanced mechanical forming process enabled our engineers to manipulate tube shapes to create the ideal blend of stiffness and comfort, as well as adding a specially shaped top tube for more comfortable carrying. The carbon fork and slender seat stays help reduce rider fatigue, while internal cable routing ensures gear shifts are clean and precise from the start of the race to the end. To all of which we can add only one thing: with a bike this good, it's a shame the cyclocross season is so short.

FRAME Aluminium Superlite, Double Butted, Advanced Mechanical Forming, Smooth Welded, Internal Cable Routing, Flat Mount Disc, 12x142mm, AXH
SIZE 50, 53, 56, 58, 61
FORK CUBE Cross Race Disc, Carbon, 1 1/8" - 1 1/2" Tapered, Flat Mount

HEADSET SA Orbit Z-t ECO, Top Zero-Stack 1 1/8" (OD 44mm), Bottom Integrated 1 1/2"
STEM Newmen Evolution 318.4, 31.8mm
HANDLEBAR Newmen Evolution Wing Bar
HANDLEBAR TAPE CUBE Grip Control
REAR DERAILLEUR Shimano GRX RD-RX812, Direct Mount, 11-Speed
SHIFT/ BRAKE LEVERS Shimano GRX ST-RX810
BRAKE SYSTEM Shimano BR-RX810, Hydr. Disc Brake, Flat Mount (160/160)
CRANKSET Shimano GRX FC-RX600, 40T, 170mm (50/53cm), 172.5mm (56cm), 175mm (58/61cm)
CASSETTE Shimano CS-M7000, 11-42T
CHAIN Shimano CN-HG601-11
WHEELSET CUBE RA 0.8 CX
TYRES Schwalbe X-One Allround, PerfL, Kevlar, 35-622
SADDLE Natural Fit Nuance Lite
SEAT POST Newmen Evolution, 27.2mm
SEATCLAMP CUBE Screwlock, 31.8mm

WEIGHT 9 kg

SPARE PARTS
8655 CUBE HANGER_rr-x12-direct-cube
10325 CUBE Headset Orbit Z-t + 1 1/8 crown race
13550 Inner Tube 28" TREKKING SV 40 mm

CROSS RACE PRO

388200 grey 'n' flashyellow



16992
CUBE SHOE COVER NEOPRENE RD

11404
SQUARE JERSEY SPORT

16248
CUBE HELMET ROAD RACE

When the cyclocross bug really bites, you'll want a bike that's up to the job. That's why we created the Cross Race Pro – a perfectly balanced, affordable and adaptable machine that's ideal for winter training, racing or exploring beyond smooth tarmac. Our understated Superlite aluminium frameset and carbon fork deliver nimble handling with comfort and pace, but we didn't stop there. Stiffness and steering precision are .cross must-haves, so we added 12mm thru axles front and rear, and a tapered steerer. Internal cable routing prevents mud and water from interfering with smooth gear shifting race after race, while the ergonomic top tube is specially designed to make shouldering the bike more comfortable. And, of course, it's all powered by Shimano's super-reliable 105 gears, complete with hydraulic disc brakes for assured stopping in even the filthiest of riding conditions. It's ready to ride... and race. Are you?

FRAME Aluminium Superlite, Double Butted, Advanced Mechanical Forming, Smooth Welded, Internal Cable Routing, Flat Mount Disc, 12x142mm, AXH
SIZE 50, 53, 56, 58, 61
FORK CUBE Cross Race Disc, Carbon, 1 1/8" - 1 1/2" Tapered, Flat Mount

HEADSET SA Orbit Z-t ECO, Top Zero-Stack 1 1/8" (OD 44mm), Bottom Integrated 1 1/2"
STEM CUBE Performance Stem Pro, 31.8mm
HANDLEBAR CUBE Compact Race Bar
HANDLEBAR TAPE CUBE Grip Control
REAR DERAILLEUR Shimano 105 RD-R7000-DGS, 11-Speed
FRONT DERAILLEUR Shimano 105 FD-R7000, 31.8mm Clamp
SHIFT/ BRAKE LEVERS Shimano 105 ST-R7020
BRAKE SYSTEM Shimano 105 BR-R7070, Hydr. Disc Brake, Flat Mount (160/160)
CRANKSET Shimano FC-R5510, 50x34T, 170mm (50/53cm), 172.5mm (56cm), 175mm (58/61cm)
CASSETTE Shimano 105 CS-HG700, 11-34T
CHAIN Shimano CN-HG601-11
WHEELSET CUBE RA 0.8 CX
TYRES Schwalbe X-One Allround, Kevlar, 35-622
SADDLE Natural Fit Venec Lite
SEAT POST CUBE Performance Post, 27.2mm
SEATCLAMP CUBE Screwlock, 31.8mm

WEIGHT 0,2 kg

SPARE PARTS#
8655 CUBE HANGER_rr-x12-direct-cube
10325 CUBE Headset Orbit Z-t + 1 1/8 crown race
13550 Inner Tube 28" TREKKING SV 40 mm

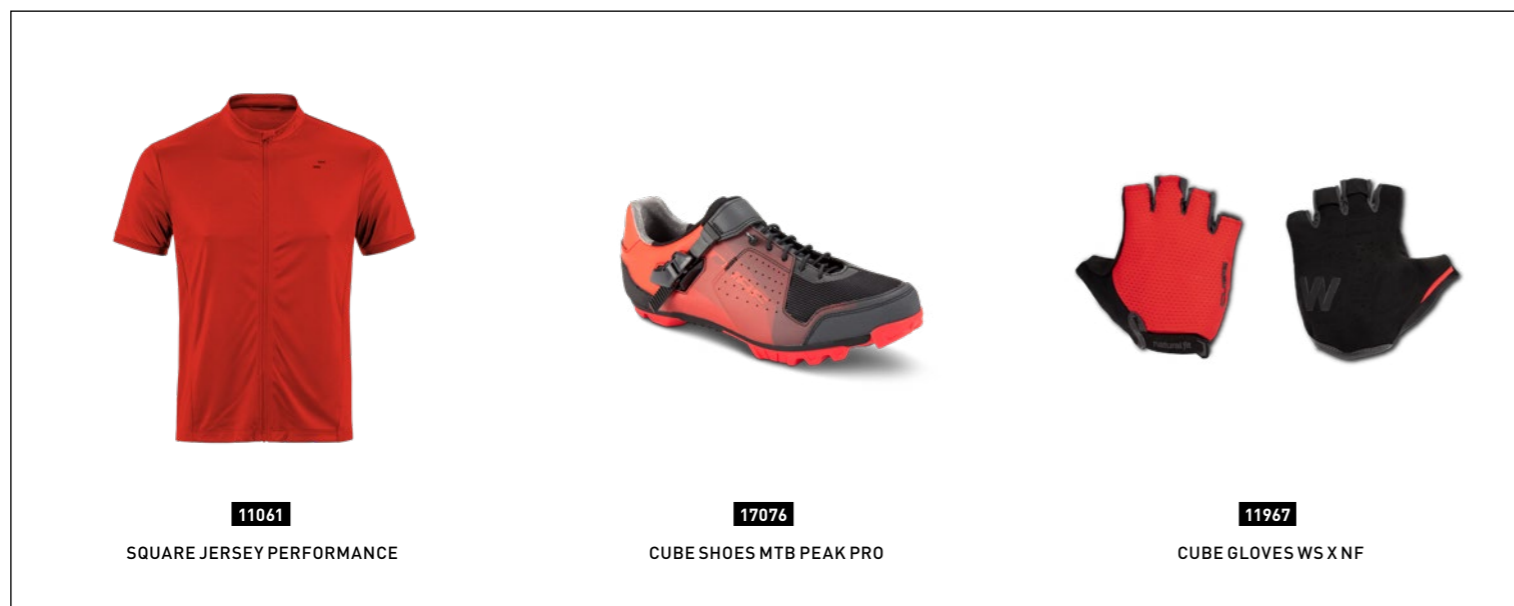

11061
SQUARE JERSEY PERFORMANCE

17076
CUBE SHOES MTB PEAK PRO

11967
CUBE GLOVES WS X NF

To the uninitiated, cyclocross racing can seem an odd way to spend a weekend. But we reckon the fast-paced racing, technical challenges and mixture of riding and running are a great way to maintain and develop fitness through the winter. Which is why we developed the Cross Race – a bike that blends race-bred handling with comfort and agility, for old school off-road thrills with a modern twist. With typical attention to detail, our engineering team didn't just build a light, stiff and strong frame – they packed it full of innovation, too. Details like the specially shaped top tube for easier shouldering of the bike, or the slender seat stays and carbon fork for greater comfort, are what make the CUBE difference. Low-maintenance Tektro Spyre disc brakes offer reliable, all-weather power through the worst that the winter can throw at you, while Shimano's evergreen 105 gears and grippy Schwalbe tyres complete the package. It all makes for a great-value cyclocross machine, covering all the bases from entry-level racing to winter training. Or, come to think of it, just sprinting off the lights when they turn green on your daily commute. A bike, indeed, not just for all reasons, but for all seasons too.

FRAME Aluminium Superlite, Double Butted, Advanced Mechanical Forming, Smooth Welded, Internal Cable Routing, Flat Mount Disc, 12x142mm, AXH
SIZE 50, 53, 56, 58, 61
FORK CUBE Cross Race Disc, Carbon, 1 1/8" - 1 1/2" Tapered, Flat Mount

HEADSET SA Orbit Z-t ECO, Top Zero-Stack 1 1/8" (OD 44mm), Bottom Integrated 1 1/2"
STEM CUBE Performance Stem Pro, 31.8mm
HANDLEBAR CUBE Compact Race Bar
HANDLEBAR TAPE CUBE Grip Control
REAR DERAILLEUR Shimano 105 RD-R7000-DGS, 11-Speed
FRONT DERAILLEUR Shimano 105 FD-R7000, 31.8mm Clamp
SHIFT/ BRAKE LEVERS Shimano 105 ST-R7000
BRAKE SYSTEM Tektro Spyre MD-C610C, Flat Mount
CRANKSET Shimano FC-R5510, 50x34T, 170mm (50/53cm), 172.5mm (56cm), 175mm (58/61cm)
CASSETTE Shimano 105 CS-HG700, 11-34T
CHAIN Shimano CN-HG601-11
WHEELSET CUBE RA 0.8 CX
SADDLE Natural Fit Venec Lite
SEAT POST CUBE Performance Post, 27.2mm
SEATCLAMP CUBE Screwlock, 31.8mm

WEIGHT 0,4 kg

SPARE PARTS#
8655 CUBE HANGER_rr-x12-direct-cube
10325 CUBE Headset Orbit Z-t + 1 1/8 crown race
13550 Inner Tube 28" TREKKING SV 40 mm

FOR us #Adventurers

When we set out to develop the Nuroad we had a destination in mind, but no specific route by which to get there. We did, however, have a lot of experience building great race and .cross bikes. Figuring that this would be a great place to start, we combined the best of both genres to create our new, super-adaptable all-rounder. So, for example, the Nuroad's geometry is based on the comfort, stability and agility of our Attain series, but the sizing is the same as our Cross Race bikes. We made sure there's plenty of clearance to run wide, grippy and comfortable tyres up to 40mm width, and even left room for mudguards with 35mm tyres too. Internal cable routing keeps your gears shifting cleanly even when the mud and water's flying around, there's a replaceable gear hanger and the carbon fork blades help take some of the vibration out of rough surfaces, so that you stay comfortable even on long rides.



NUROAD SL

380300 titanium'n'orange

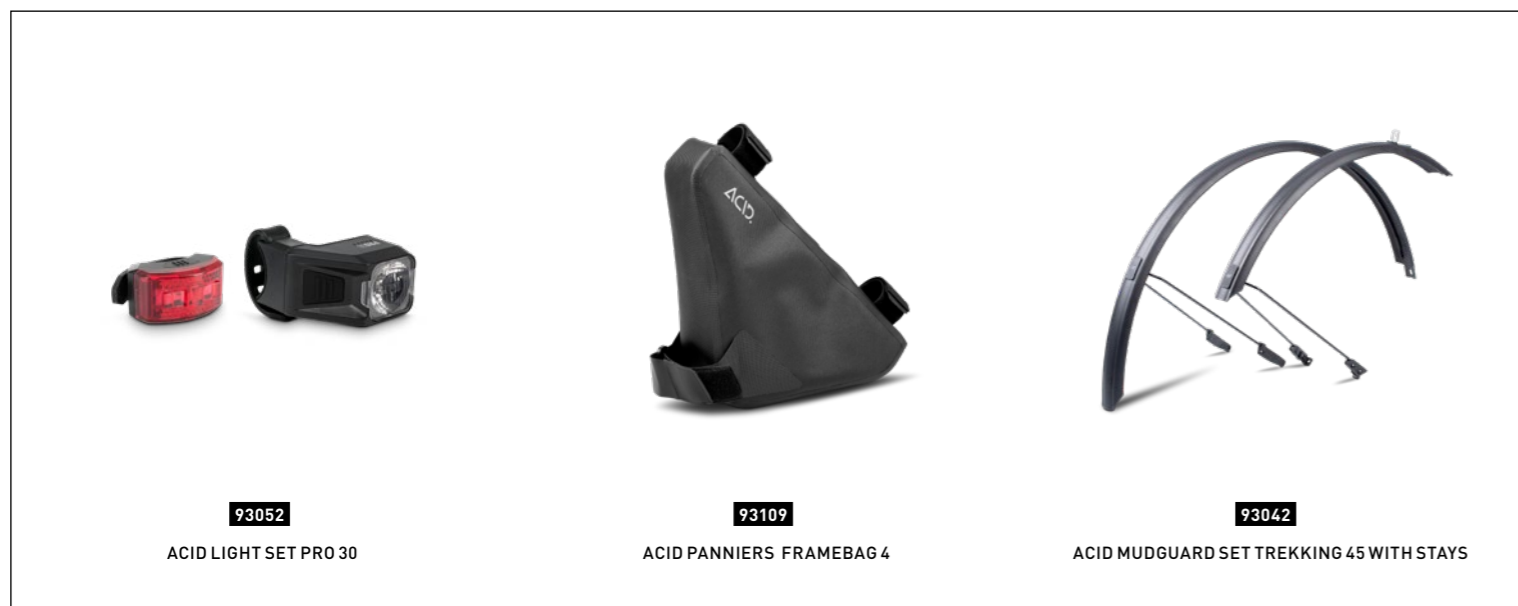

93052
ACID LIGHT SET PRO 30



93109
ACID PANNIERS FRAMEBAG 4



93042
ACID MUDGUARD SET TREKKING 45 WITH STAYS

In the early days of Alpine road racing the roads were often little more than dirt tracks – which means that the Tour de France riders of nearly a century ago would probably have given up a limb for one of our Nuroad SLs. With the pace and comfort of our Attain road race series and the handling and ruggedness of one of our Cross Race bikes, its DNA is pure racing tradition. Featuring Shimano's new 1x11 GRX transmission with a wide-ranging 11-42 tooth cassette, our product engineers have selected a range of components that are designed for one purpose: to boost your speed. From the 40mm Kevlar tyres – wide, grippy, comfortable and light – to the hydraulic disc brakes and Mavic Allroad Disc wheelset, this is an uncompromisingly rapid gravel machine. The frame features all the benefits of our Nuroad series, including neat internal cable routing and a geometry that makes handling the variable grip of unsurfaced roads easier. We even fitted a full carbon fork, which saves weight and adds to ride comfort. Wherever you're heading this weekend, however remote or rough the road surface, the Nuroad SL has got your back. Where will it take you next?

FRAME Aluminium 6061 T6 Superlite, Gravel Comfort Geometry, Flat Mount Disc, Fender & Rack Option, 12x142mm, AXH
SIZE 50, 53, 56, 58, 61
FORK CUBE Nuroad Dis C:62 Technology, Carbon Blades, 1 1/8" - 1 1/2" Tapered, Flat Mount, 12x100mm

HEADSET SA Orbit Z-t ECO, Top Zero-Stack 1 1/8" (OD 44mm), Bottom Integrated 1 1/2"
STEM Newmen Evolution 318.4, 31.8mm
HANDLEBAR CUBE Gravel Race Bar
HANDLEBAR TAPE CUBE Grip Control
REAR DERAILLEUR Shimano GRX RD-RX812, Direct Mount, 11-Speed
SHIFT/ BRAKE LEVERS Shimano GRX ST-RX810
BRAKE SYSTEM Shimano BR-RX810, Hydr. Disc Brake, Flat Mount (160/160)
CRANKSET Shimano GRX FC-RX600, 40T, 170mm (50/53cm), 172.5mm (56/58cm), 175mm (61cm)
CASSETTE Shimano CS-M7000, 11-42T
CHAIN Shimano CN-HG601-11
WHEELSET Mavic Allroad Disc
TYRES Schwalbe G-One Allround, Kevlar, 40-622
SADDLE Natural Fit Nuance Lite
SEAT POST Newmen Evolution, 27.2mm
SEATCLAMP CUBE Screwlock, 31.8mm

WEIGHT 8 kg

SPARE PARTS
8655 CUBE HANGER_rr-x12-direct-cube
10325 CUBE Headset Orbit Z-t + 1 1/8 crown race
13550 Inner Tube 28" TREKKING SV 40 mm
93042 ACID Mudguard Set TREKKING 45 with Stays

NUROAD RACE FE

380210 black'n'iridium



Fast, fun, versatile: an impossible combination? Not with the Nuroad Race FE. Featuring Shimano's new gravel-friendly GRX 2x11 transmission and hydraulic disc brakes, we combined all the best qualities of our Attain and Cross Race series, then threw in a dynamo-powered Supernova E3 lighting system and an Acid SL luggage carrier, too. The 35mm Schwalbe tyres are fast, grippy and comfortable and leave plenty of room for the Acid Gravel mudguards, so you can stay cleaner and drier whatever the weather throws at you. And, as you'd expect, the Nuroad Race FE's lightweight aluminium frame is built for comfort, confidence-inspiring handling and all-round versatility. Internal cable routing keeps gear shifts clean even in gritty or muddy conditions, and a replaceable derailleur hanger means that an accident doesn't mean a written-off frame. The result of all this attention to detail? An adventurous, adaptable thoroughbred. Take the less obvious route to work or load up for a longer backcountry trip; either way, the Nuroad Race FE will get you there quickly, in comfort and wearing a big grin.

-  **FRAME** # Aluminium 6061 T6 Superlite, Gravel Comfort Geometry, Flat Mount Disc, Fender & Rack Option, 12x142mm, AXH
 - SIZE** # 50, 53, 56, 58, 61
 - FORK** # CUBE Nuroad Disc, One Piece 3D-Forged Steerer/Crown, Carbon Blades, 1 1/8" - 1 1/2" Tapered, Flat Mount, 12x100mm
-
-  **HEADSET** # SA Orbit Z-t ECO, Top Zero-Stack 1 1/8" (OD 44mm), Bottom Integrated 1 1/2"
 - STEM** # CUBE Performance Stem Pro, 31.8mm
 - HANDLEBAR** # CUBE Gravel Race Bar
 - HANDLEBAR TAPE** # CUBE Grip Control
 - REAR DERAILLEUR** # Shimano GRX RD-RX810, Direct Mount, 11-Speed
 - FRONT DERAILLEUR** # Shimano GRX FD-R810
 - SHIFT/ BRAKE LEVERS** # Shimano GRX ST-RX600
 - BRAKE SYSTEM** # Shimano BR-RX400, Hydr. Disc Brake, Flat Mount (160/160)
 - CRANKSET** # Shimano GRX FC-RX600, 46x30T, 170mm (50/53cm), 172.5mm (56/58cm), 175mm (61cm)
 - CASSETTE** # Shimano 105 CS-HG700, 11-34T
 - CHAIN** # Shimano CN-HG600-11
 - WHEELSET** # CUBE RA 0.8 CX w/ hub dynamo
 - TYRES** # Schwalbe G-One Speed, Perf. Kevlar, 35-622
 - SADDLE** # Natural Fit Venec Lite
 - SEAT POST** # CUBE Performance Post, 27.2mm
 - SEATCLAMP** # CUBE Screwlock, 31.8mm
 - FRONT LIGHT** # Supernova E3 Pure 3
 - REAR LIGHT** # Supernova E3 Tail Light 2
 - MUDGUARDS** # Acid 45
 - BELL** # Knog Oi
 - CARRIER** # Acid SL Carrier

 **WEIGHT** # 1,7 kg

-  **SPARE PARTS**
- 10063** CUBE Hanger Attain/Agree/Cross Race/Gravel
- 10325** CUBE Headset Orbit Z-t + 1 1/8 crown race
- 33041** CUBE Bar Tape Carbon



11289
CUBE TOUR JERSEY



93100
ACID PANNIERS TRAVLR 15



11282
CUBE TOUR BAGGY SHORTS

NUROAD RACE

380200 black 'n' greyblue



Fancy taking the long way home, even if it means leaving the reassuring smoothness of tarmac behind? You'll be needing one of these, then. Featuring Shimano's new gravel-specific GRX 2x11 groupset, the Nuroad Race combines all the best qualities of our road race and cyclocross series in a rugged, versatile and lively bike that'll have you seeking out new routes to explore. With 40mm Schwalbe tyres, the huge gear range offered by GRX and the power of hydraulic disc brakes, it's fully equipped to keep going when other bikes have long since given up and turned around. Our engineers used the same geometry as our Attain Road series, designed for day-long comfort, reassuring stability and inspirational agility when you need it. The carbon bladed fork is specifically designed to help filter out vibrations from the road surface too, improving comfort even on longer rides. Whether you fancy mixing up your training rides or have a longer trip in a remote area in mind, the Nuroad Race will help you go further.

FRAME Aluminium 6061 T6 Superlite, Gravel Comfort Geometry, Flat Mount Disc, Fender & Rack Option, 12x142mm, AXH
SIZE 50, 53, 56, 58, 61
FORK CUBE Nuroad Disc, One Piece 3D-Forged Steerer/Crown, Carbon Blades, 1 1/8" - 1 1/2" Tapered, Flat Mount, 12x100mm

HEADSET SA Orbit Z-t ECO, Top Zero-Stack 1 1/8" (OD 44mm), Bottom Integrated 1 1/2"
STEM CUBE Performance Stem Pro, 31.8mm
HANDLEBAR CUBE Gravel Race Bar
HANDLEBAR TAPE CUBE Grip Control
REAR DERAILLEUR Shimano GRX RD-RX810, Direct Mount, 11-Speed
FRONT DERAILLEUR Shimano GRX FD-R810
SHIFT/ BRAKE LEVERS Shimano GRX ST-RX600
BRAKE SYSTEM Shimano BR-RX400, Hydr. Disc Brake, Flat Mount (160/160)
CRANKSET Shimano GRX FC-RX600, 46x30T, 170mm (50/53cm), 172.5mm (56/58cm), 175mm (61cm)
CASSETTE Shimano 105 CS-HG700, 11-34T
CHAIN Shimano CN-HG600-11
WHEELSET CUBE RA 0.8 CX
TYRES Schwalbe G-One Allround, Perf. Kevlar, 40-622
SADDLE Natural Fit Venec Lite
SEAT POST CUBE Performance Post, 27.2mm
SEATCLAMP CUBE Screwlock, 31.8mm

WEIGHT 0,2 kg

SPARE PARTS#
8655 CUBE HANGER_rr-x12-direct-cube
10325 CUBE Headset Orbit Z-t + 1 1/8 crown race
13550 Inner Tube 28" TREKKING SV 40 mm
93042 ACID Mudguard Set TREKKING 45 with Stays

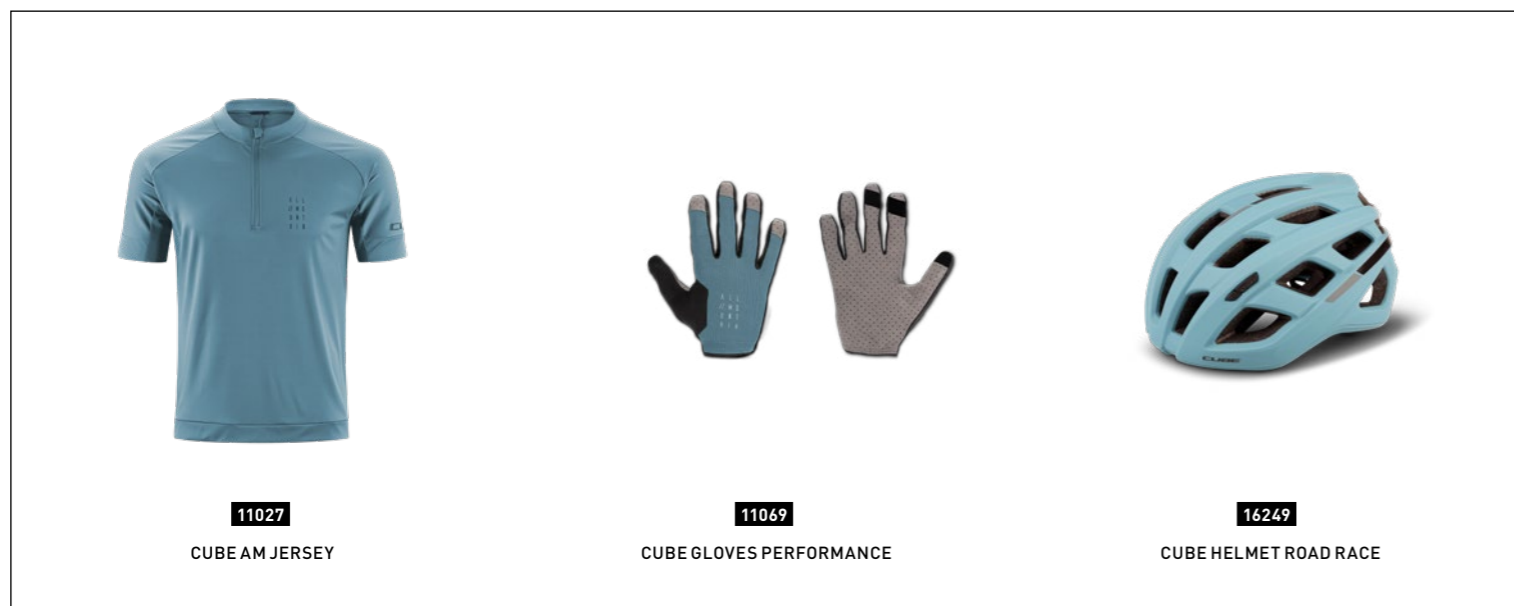

11027
CUBE AM JERSEY



11069
CUBE GLOVES PERFORMANCE



16249
CUBE HELMET ROAD RACE



There's more than one way to build a versatile, go-almost-anywhere bike – and sometimes the simplest solutions are the best. For the Nuroad Pro FE we took the proven benefits of our Nuroad Pro – stable handling, rugged design, all-road capability – and added a full complement of accessories to make it tour- or commuter-ready. So there's a sturdy rear luggage carrier, full-length Acid Gravel mudguards and a front and rear lighting system. And the frame features the same comfort and easy handling as the Nuroad Pro, combined with a carbon bladed fork and deliberately slender seat stays for added comfort on rough surfaces. We routed cables inside the frame, to make them almost impervious to the effects of water, mud and grit – which means your gears will keep shifting cleanly ride after ride, even in terrible weather conditions. Combined with the powerful Tektro Spyre mechanical disc brakes, reliable Shimano Tiagra 10-speed transmission and grippy, durable Schwalbe tyres, it's all you need for taking everything from the daily commute to multi-day touring trips in your stride.

- FRAME#** Aluminium 6061 T6 Superlite, Gravel Comfort Geometry, Flat Mount Disc, Fender & Rack Option, 12x142mm, AXH
- SIZE#** 50, 53, 56, 58, 61
- FORK#** CUBE Nuroad Disc, One Piece 3D-Forged Steerer/Crown, Carbon Blades, 1 1/8" - 1 1/2" Tapered, Flat Mount, 12x100mm
- HEADSET#** SA Orbit Z-t ECO, Top Zero-Stack 1 1/8" (OD 44mm), Bottom Integrated 1 1/2"
- STEM#** CUBE Performance Stem Pro, 31.8mm
- HANDLEBAR#** CUBE Gravel Race Bar
- HANDLEBAR TAPE#** CUBE Grip Control
- REAR DERAILLEUR#** Shimano Tiagra RD-4700GS, 10-Speed
- FRONT DERAILLEUR#** Shimano Tiagra FD-4700, 31.8mm Clamp
- SHIFT/ BRAKE LEVERS#** Shimano Tiagra ST-4700
- BRAKE SYSTEM#** RP Spyre MD-C610C, Flat Mount
- CRANKSET#** Shimano Tiagra FC-4700, 50x34T, 170mm (50/53cm), 172.5mm (56/58cm), 175mm (61cm)
- CASSETTE#** Shimano CS-HG500, 11-34T
- CHAIN#** MC X10
- WHEELSET#** CUBE RA 0.8 CX w/ hub dynamo
- TYRES#** Schwalbe G-One Speed, Perf. Kevlar, 35-622
- SADDLE#** Natural Fit Venec Lite
- SEAT POST#** CUBE Performance Post, 27.2mm
- SEATCLAMP#** CUBE Screwlock, 31.8mm
- FRONT LIGHT#** XA Compactline 20
- REAR LIGHT#** Busch & Müller Toplight
- MUDGUARDS#** CID 45
- BELL#** Mini Bell
- CARRIER#** CID SL Carrier

WEIGHT# 1,9 kg

- SPARE PARTS#**
- 8654** CUBE HANGER_mtb/rr-x12-std (18-06267)
- 10325** CUBE Headset Orbit Z-t + 1 1/8 crown race
- 13550** Inner Tube 28" TREKKING SV 40 mm

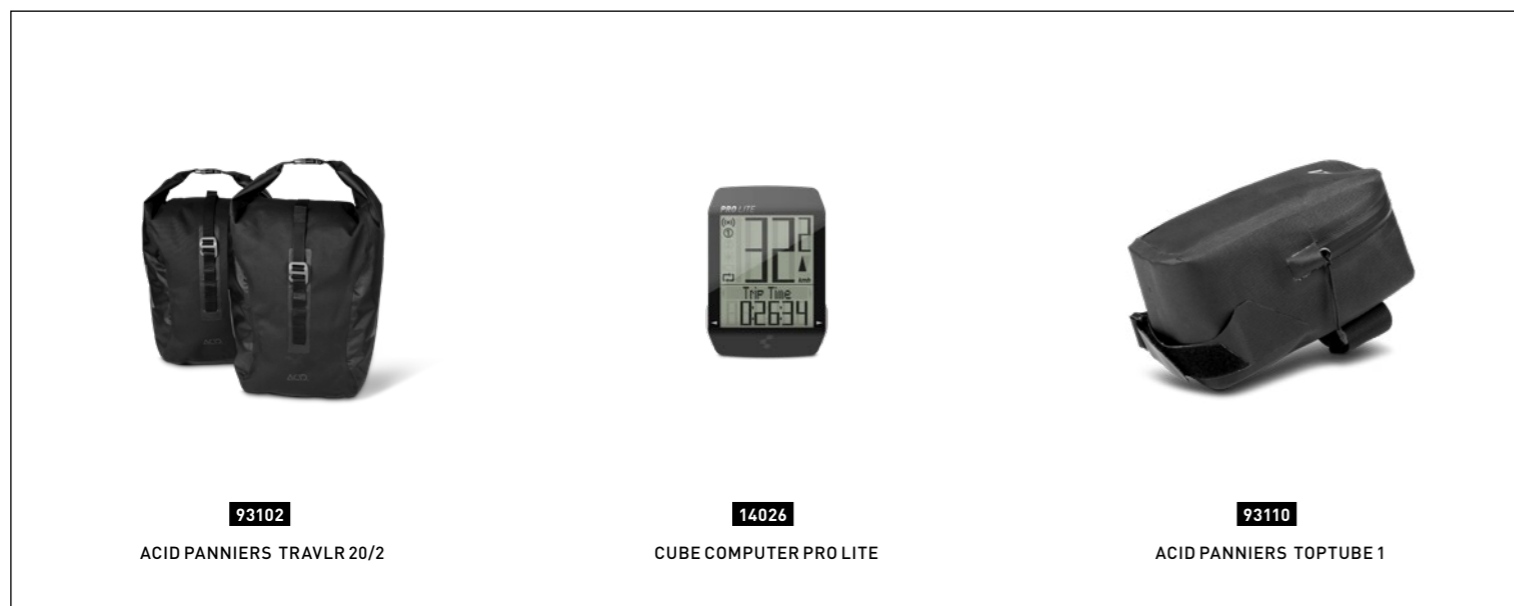

93102
ACID PANNIERS TRAVLR 20/2

14026
CUBE COMPUTER PRO LITE

93110
ACID PANNIERS TOPTUBE 1

NUROAD PRO

380100 black'n'sharpgreen



16990
CUBE SHOE COVER RAIN

10959
CUBE BLACKLINE RAIN SHORTS

10961
CUBE BLACKLINE RAIN JACKET REFLECTIVE

When the road turns to dirt, what if you didn't have to turn around and go back the way you came? We built the Nuroad Pro to answer that question... and feed your spirit of adventure. Bridging the gap between tarmac and gravel, it's a machine that's tailor-made for riders who just want to find out what's around the next corner. Nimble, adaptable and designed to have the ability to go pretty much anywhere your curiosity takes you, the wide 40mm section Schwalbe tyres will take even the roughest of road surfaces in their stride. Drawing on our experience of creating great-riding .cross bikes, the Nuroad Pro's frame takes everything we've learnt about off-road-capable drop-bar bikes and road-racing bikes, and condenses it into a frame that combines the best of both worlds. So, for example, the geometry is based on the comfort, stability and agility of our Attain road series, but the sizing is the same as our Cross Race bikes. You can run up to a 35mm tyre and still have room for mudguards. The carbon blade fork and skinny seat stays help keep things comfortable in the rough and, with a reliable Shimano Tiagra 2x10-speed transmission and Tektro Spyre mechanical disc brakes, you've everything you need to ride to the edge of your world and beyond.

FRAME# Aluminium 6061 T6 Superlite, Gravel Comfort Geometry, Flat Mount Disc, Fender & Rack Option, 12x142mm, AXH
SIZE# 50, 53, 56, 58, 61
FORK# CUBE Nuroad Disc, One Piece 3D-Forged Steerer/Crown, Carbon Blades, 1 1/8" - 1 1/2" Tapered, Flat Mount, 12x100mm

HEADSET# SA Orbit Z-t ECO, Top Zero-Stack 1 1/8" (OD 44mm), Bottom Integrated 1 1/2"
STEM# CUBE Performance Stem Pro, 31.8mm
HANDLEBAR# CUBE Gravel Race Bar
HANDLEBAR TAPE# CUBE Grip Control
REAR DERAILLEUR# Shimano Tiagra RD-4700GS, 10-Speed
FRONT DERAILLEUR# Shimano Tiagra FD-4700, 31.8mm Clamp
SHIFT/ BRAKE LEVERS# Shimano Tiagra ST-4700
BRAKE SYSTEM# RP Spyre MD-C610C, Flat Mount
CRANKSET# Shimano Tiagra FC-4700, 50x34T, 170mm (50/53cm), 172.5mm (56/58cm), 175mm (61cm)
CASSETTE# Shimano CS-HG500, 11-34T
CHAIN# KMC X10
WHEELSET# CUBE RA 0.8 CX
TYRES# Schwalbe G-One Allround, Perf. Kevlar, 40-622
SADDLE# Natural Fit Venec Lite
SEAT POST# CUBE Performance Post, 27.2mm
SEATCLAMP# CUBE Screwlock, 31.8mm

WEIGHT# 0,7 kg

SPARE PARTS#
8654 CUBE HANGER_mtb/rr-x12-std (18-06267)
10325 CUBE Headset Orbit Z-t + 1 1/8 crown race
13550 Inner Tube 28" TREKKING SV 40 mm
93042 ACID Mudguard Set TREKKING 45 with Stays

FOR us #Commuters

The SL Road's aluminium frame is made from extremely light double-buttressed tubes, giving the best combination of low weight, superb strength and great ride quality. The frame's inherent rigidity and low weight help convert energy at the pedals into efficient forward propulsion... which means speed! For the lightweight fork's design, we took our inspiration from our racing bikes. The aero shape is exceptionally stiff for accurate steering, and it even looks fast to match the bike's purity of purpose. We also routed the cables inside the down tube, adding to the bike's sleek looks and reducing wear and tear in the process – because you should be able to spend your time riding your bike, not maintaining it.



ROAD RACE

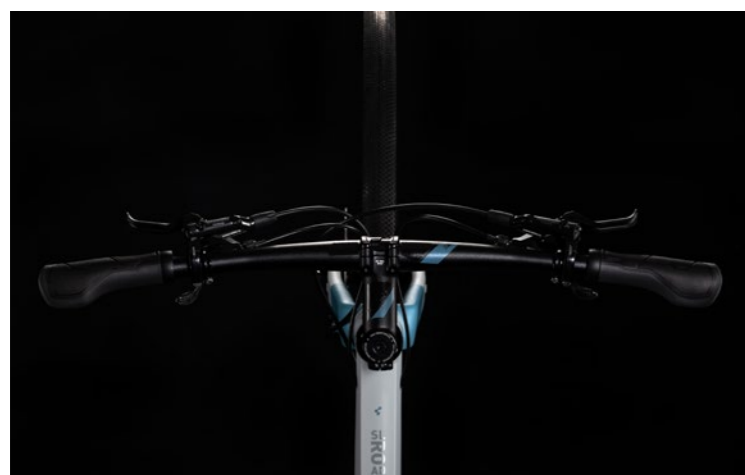

Higher, further, faster more... the SL Road SL could have been built for Strava KOM chasers or, in fact, anyone who enjoys the thrill of greater speed and more distance. A featherweight, minimalist speed package combining Shimano's superb Ultegra groupset, powerful hydraulic disc brakes and DT Swiss wheels, it's crying out to be ridden hard. The frame fulfils three vital criteria: it's light, it's stiff and it looks great. With its carbon bladed fork it's surprisingly comfortable, too. Cables are routed inside the down tube to preserve the frame's good looks and the accuracy of the gears, and we even remembered to include fixing points for accessories like mudguards and luggage carriers. In the right hands, there's no reason why this bike shouldn't be very nearly as fast as a race bike. You have been warned...

-  **FRAME#** Aluminium Superlite Crossroad Taper Double Butted
- SIZE#** Men: 50, 53, 56, 59, 62
- FORK#** CUBE Road Race, Carbon, Disc, Taper

-  **HEADSET#** SA Orbit Z-t, Top Zero-Stack 1 1/8" (OD44mm), Bottom Integrated 1 1/2"
- STEM#** CUBE Performance Stem Pro, 31.8mm
- HANDLEBAR#** CUBE Flat Race Bar, 660mm
- GRIPS#** Natural Fit Tour
- REAR DERAILLEUR#** Shimano Ultegra RD-R8000-GS, 11-Speed
- SHIFTERS#** Shimano SL-RS700
- FRONT DERAILLEUR#** Shimano Ultegra FD-R8000-BM, 31.8mm Clamp
- BRAKE SYSTEM#** Shimano Deore BR-M6000, Hydr. Disc Brake (160/160)
- CRANKSET#** Shimano Ultegra FC-R8000, Hollowtech II, 50x34T, 170mm
- CASSETTE#** Shimano Ultegra CS-R8000, 11-32T
- CHAIN#** Shimano CN-HG700-11
- WHEELSET#** DT Swiss P1800 Spline, QR/QR, Disc
- TYRES#** Schwalbe G-One Allround, Perf. Kevlar, 40-622
- PEDALS#** CUBE PP MTB
- SADDLE#** Natural Fit Venec Lite
- SEAT POST#** CUBE Performance Post, 27.2mm
- SEATCLAMP#** CUBE Screwlock, 31.8mm

 **WEIGHT#**,8 kg

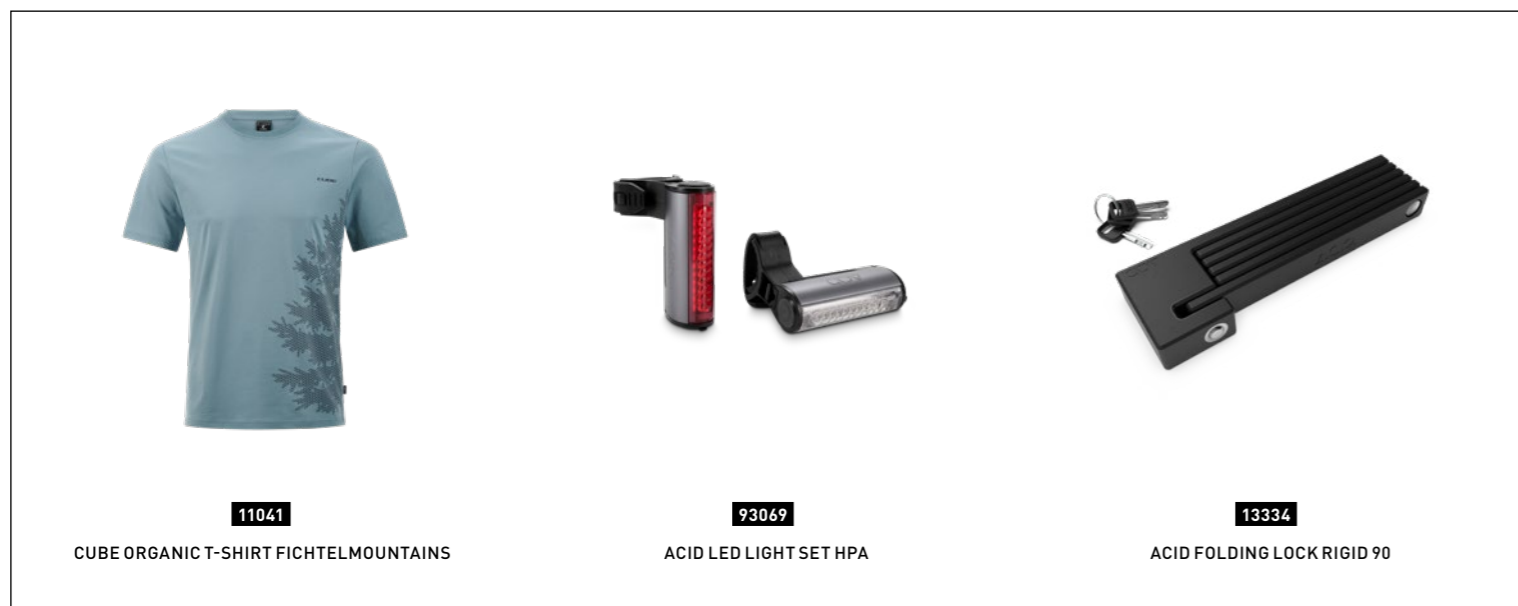

11041
CUBE ORGANIC T-SHIRT FICHEL MOUNTAINS

93069
ACID LED LIGHT SET HPA

13334
ACID FOLDING LOCK RIGID 90

-  **SPARE PARTS#**
- 10148** CUBE Hanger #148 short version
- 10325** CUBE Headset Orbit Z-t + 1 1/8 crown race
- 13816** CUBE Kickstand Cubestand PRO

SL ROAD RACE

351300 iridium'n'green



Meet the SL Road Race – a pared-down mile-muncher built for speed and simplicity. We've combined the best of our road racing and mountain bike technologies, resulting in sleek looks and low weight. A slick-shifting Shimano 105 2x11-speed transmission gives you the gear range you need in a lighter, easier-to-use format, while powerful hydraulic disc brakes put all-weather stopping ability at your fingertips and wide, grippy 40mm Schwalbe G-One Allround tyres ensure you're always in full control on even rougher roads. We've put just as much thought into the frame, which features double-butted aluminium tubes for a light, stiff but comfortable chassis that's passed all our stringent in-house testing with flying colours. Smooth Welding is as durable as it is sleek, and the carbon-bladed fork helps filter out high-frequency vibrations for even greater comfort. We even routed cables internally – neat, tidy and secure – for reduced maintenance and improved gear-shifting performance. Head out into the country or across town – either way, you'll want to be aboard the SL Road Race.

- FRAME#** Aluminium Superlite Crossroad Taper Double Butted
- SIZE#** Men: 50, 53, 56, 59, 62
- FORK#** CUBE Road Race, Carbon, Disc, Taper

- HEADSET#** SA Orbit Z-t ECO, Top Zero-Stack 1 1/8" (OD44mm), Bottom Integrated 1 1/2"
- STEM#** CUBE Performance Stem Pro, 31.8mm
- HANDLEBAR#** CUBE Flat Race Bar, 660mm
- GRIPS#** Natural Fit Tour
- REAR DERAILLEUR#** Shimano 105 RD-R7000-GS, 11-Speed
- SHIFTERS#** Shimano SL-RS700
- FRONT DERAILLEUR#** Shimano 105 FD-R7000, 31.8mm Clamp
- BRAKE SYSTEM#** Shimano BR-MT200, Hydr. Disc Brake (160/160)
- CRANKSET#** Shimano 105 FC-R7000, 50x34T
- CASSETTE#** Shimano 105 CS-HG700, 11-34T
- CHAIN#** Shimano CN-HG601-11
- RIMS#** CUBE RA 0.8, 32H, Disc
- FRONT HUB#** Shimano Deore HB-M6000, Centerlock
- REAR HUB#** Shimano Deore FH-M6000, Centerlock
- TYRES#** Schwalbe G-One Allround, Kevlar, 40-622
- PEDALS#** CUBE PP MTB
- SADDLE#** Natural Fit Venec Lite
- SEAT POST#** CUBE Performance Post, 27.2mm
- SEATCLAMP#** CUBE Screwlock, 31.8mm

WEIGHT# 0,6 kg

- SPARE PARTS#**
- 10148** CUBE Hanger #148 short version
- 10325** CUBE Headset Orbit Z-t + 1 1/8 crown race
- 13548** Inner Tube 28" TREKKING AGV 40 mm

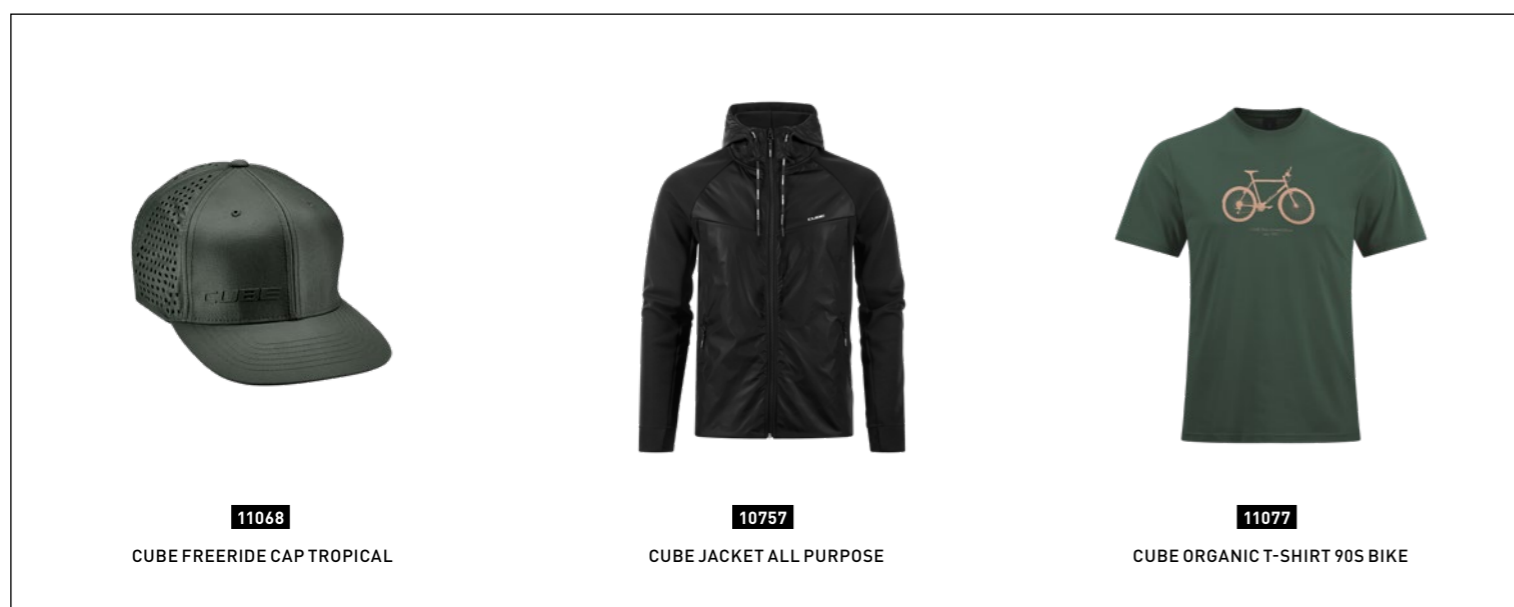

11068
CUBE FREERIDE CAP TROPICAL

10757
CUBE JACKET ALL PURPOSE

11077
CUBE ORGANIC T-SHIRT 90S BIKE

SL ROAD PRO

351200 | Trapeze | iridium'n'blue



SL ROAD PRO

351200 | iridium'n'blue

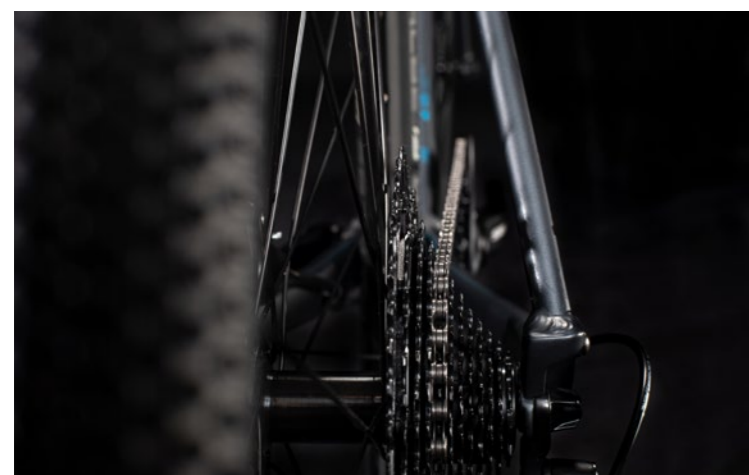

A high-performance, great-value bike for riders who value both speed and simplicity, the SL Road Pro's heart is a light, stiff chassis constructed from double-buttressed aluminium tubes. The frame's inherent rigidity and low weight help convert energy at the pedals into efficient forward propulsion... which means speed! The matching aluminium fork is a perfect fit for the frame, featuring a tapered steerer for maximum steering precision. And, in keeping with the bike's minimalist appeal, we've routed cables internally for a cleaner appearance and improved gear-shifting performance with reduced maintenance. Powerful hydraulic disc brakes ensure you can slow and stop safely in all weathers and Sram's superb 1x12 gears give you the range you need for both town and country. There's nothing here that you don't need, but everything that you do. Experience cycling in its purest form – ride the SL Road Pro.

-  **FRAME** Aluminium Superlite Crossroad Taper Double Butted
- SIZE** Men: 50, 53, 56, 59, 62, Trapeze: 47, 50, 53
- FORK** Aluminium Rigid Fork

-  **HEADSET** SA Orbit Z-t ECO, Top Zero-Stack 1 1/8" (OD44mm), Bottom Integrated 1 1/2"
- STEM** CUBE Performance Stem Pro, 31.8mm
- HANDLEBAR** CUBE Flat Race Bar, 660mm
- GRIPS** Natural Fit Tour
- REAR DERAILLEUR** Sram GX Eagle™, 12-Speed
- SHIFTERS** Sram NX Eagle™ Trigger
- BRAKE SYSTEM** Shimano BR-MT200, Hydr. Disc Brake (160/160)
- CRANKSET** Sram S650 Eagle™, 38T, 170mm
- CASSETTE** Sram XG-1230, 11-50T
- CHAIN** Sram NX Eagle™
- RIMS** CUBE RA 0.8, 32H, Disc
- FRONT HUB** Shimano HB-TX505, QR, Centerlock
- REAR HUB** Shimano FH-TX505, QR, Centerlock
- TYRES** Schwalbe G-One Allround, Perf. Kevlar, 40-622
- PEDALS** CUBE PP MTB
- SADDLE** Natural Fit Venec Lite
- SEAT POST** CUBE Performance Post, 27.2mm
- SEATCLAMP** CUBE Screwlock, 31.8mm

-  **WEIGHT** #1,2 kg



11960

CUBE GLOVES XNF



16284

CUBE HELMET CINITY



13322

ACID CHAIN COMBINATION LOCK CORVID C80

-  **SPARE PARTS**
- 10024** CUBE Disc Brake Pad Shimano Deore BR-M505/515/525/445/446
- 10148** CUBE Hanger #148 short version
- 10325** CUBE Headset Orbit Z-t + 1 1/8 crown race

SL ROAD

351100 | Trapeze | red 'n' grey



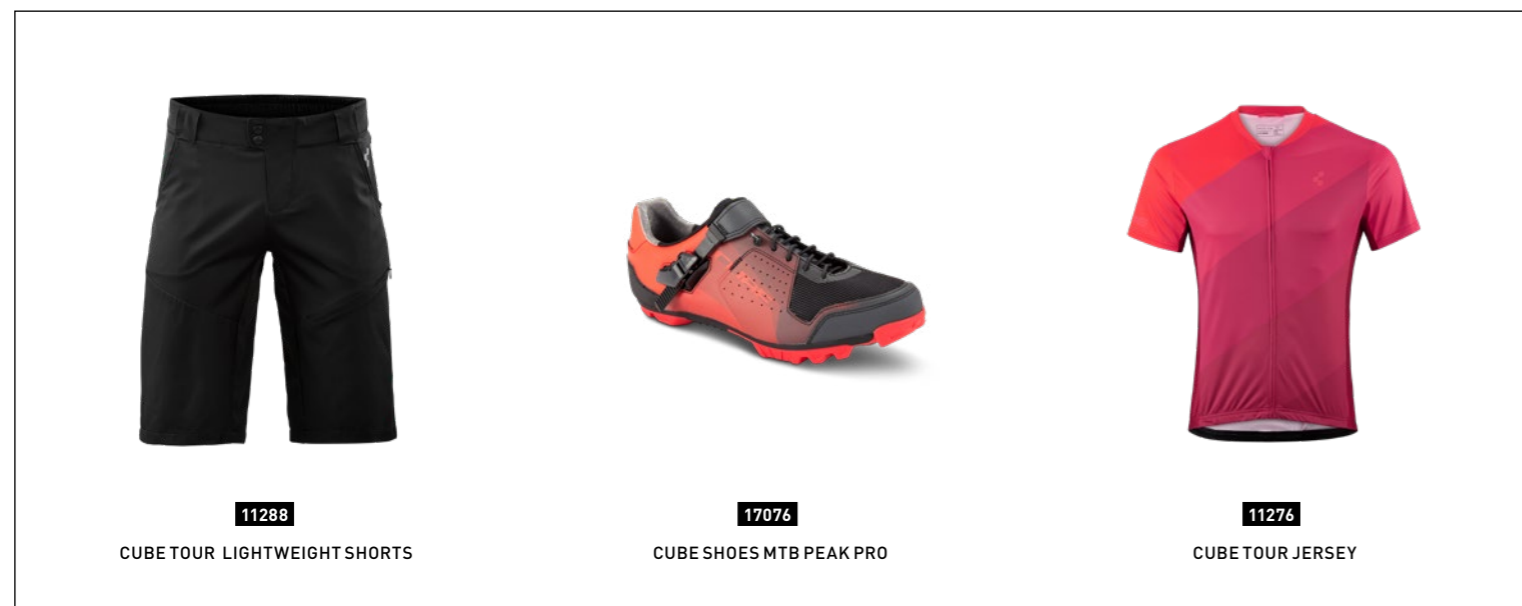

SL ROAD

351100 | red 'n' grey



The SL Road is cycling stripped down to arguably its purest form. Sleek, light and simple, its sole purpose is to transport you from A to B with the minimum of fuss. Featuring an aluminium frame built from light, strong, double-butted tubes for the best combination of strength, comfort and durability, we matched this efficiently pared-down chassis with a rigid aluminium fork for nimble handling and low weight. Reliable, slick-shifting Shimano 2x8-speed gears keep working smoothly through all weathers, thanks partly to internal cable routing and its ability to reduce wear and tear. And powerful hydraulic disc brakes mean you'll always be in control, so you can stop safely in all weathers. It may lack bells, whistles and other adornments, but the SL Road's simplicity is its raison d'être. Fast from point to point, whether on your daily commute or a training ride on country roads, it represents both great value and minimalist cool. What more could you need?

-  **FRAME** # Aluminium Superlite Crossroad Taper Double Butted
- SIZE** # Men: 50, 53, 56, 59, 62, Trapeze: 47, 50, 53
- FORK** # Aluminium Rigid Fork

-  **HEADSET** # SA Orbit Z-t ECO, Top Zero-Stack 1 1/8" (OD44mm), Bottom Integrated 1 1/2"
- STEM** # CUBE Performance Stem Pro, 31.8mm
- HANDLEBAR** # CUBE Flat Race Bar, 660mm
- GRIPS** # CUBE Performance Grip
- REAR DERAILLEUR** # Shimano Claris RD-R2000-SS, 8-Speed
- SHIFTERS** # Shimano Claris SL-R2000
- FRONT DERAILLEUR** # Shimano Claris FD-R2000-BM, 31.8mm Clamp
- BRAKE SYSTEM** # Shimano BR-MT200, Hydr. Disc Brake (160/160)
- CRANKSET** # Shimano Claris FC-R2000, 50x34T, BB-RS500, 170mm
- CASSETTE** # Shimano CS-HG200, 12-32T
- CHAIN** # MC Z51
- RIMS** # CUBE ZX20, 32H, Disc
- FRONT HUB** # Shimano HB-TX505, QR, Centerlock
- REAR HUB** # Shimano FH-TX505, QR, Centerlock
- TYRES** # Schwalbe CX Comp, 40-622
- PEDALS** # CUBE PP MTB
- SADDLE** # Natural Fit Venec Lite
- SEAT POST** # CUBE Performance Post, 27.2mm
- SEATCLAMP** # CUBE Screwlock, 31.8mm

-  **WEIGHT** # 1,4 kg

-  **SPARE PARTS** #
- 10024** CUBE Disc Brake Pad Shimano Deore BR-M505/515/525/445/446
- 10148** CUBE Hanger #148 short version
- 10325** CUBE Headset Orbit Z-t + 1 1/8 crown race

T
A
L
L

R
T
O

I
H
N



- 216 **AERIUM C:68**
- 224 **AERIUM C:68 TT**
- 228 **AERIUM RACE**

TRIATHLON

TRIATHLON

TIME TRIAL

TIME TRIAL



AERIUM C:68

No compromise, no limits. Built from the ground up to be the best-performing, most aerodynamic time trial bike around, the Aerium C:68 sets new standards for wind-cheating efficiency and rider comfort. From food and water storage to brake integration, we've sweated the details so you can just pedal.

AERIUM C:68 TT

Fast, faster, fastest. The all new Aerium TT takes all our aero experience and repackages it, using our C:68 carbon, in a form that's as efficient through the air as we can possibly make it. We could tell you about the advanced fluid dynamics that went into it, but all you need to know is this: it's the fastest TT bike we've ever made.

AERIUM RACE

Speed has a new name - the Aerium Race is the bike that'll help you nudge your personal bests into new territory. From the wind tunnel tested frame to the ultra-reliable components, it won't let you down when the pressure's on.

FOR us #Racers

There's more to developing a wind-cheating bike than giving it lots of .aero' shaped tubes. That's why we worked with the development team at Formula One specialists SwissSide, whose experience in reducing drag proved invaluable in building a new standard in triathlon bikes. Wind tunnel testing helped us to reduce the effects of crosswinds and turbulence, giving the Aerium C:68 not just incredible straight-line speed but impressive stability out in real world riding conditions, too. Low seat stays help to reduce the frontal area, while the unique slotted head tube acts as a spoiler. The hydraulic brake system, developed in conjunction with Magura, is designed for quick wheel changing and easy adjustment – and, of course, all cables and hoses are hidden away, out of the wind. We even included food storage and drinking systems into the frame, both of which are accessible without moving from the aero riding position. With completely enclosed cables and hydraulic brake hoses, every single detail is there for one purpose only: to help you to go faster. We know from our testing that this is the fastest triathlon frame available. Are you ready to up your game?



AERIUM C:68 SLT 1X12

386320 LOW carbon'n'red

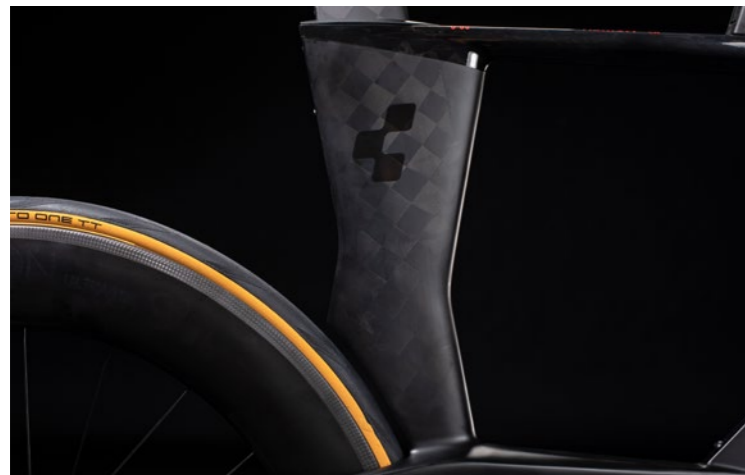

When you've put in the hours on your training, you'll want a bike that's capable of making the best of your efforts. The Aerium C:68 SLT is that bike – utterly uncompromising in both design and execution to match your uncompromising approach to racing. Developed in conjunction with the aerodynamics specialists at SwissSide, our engineering team began by ditching UCI regulations and setting a new goal: sheer, unadulterated speed, with no design limits. Using a combination of sophisticated computer modelling, wind tunnel testing and real-world data-logging, the result is a bike that out-performs all its competitors in our tests. It slices through the air thanks to its frontal area-reducing dropped seat stays and unique slotted head tube design. It's even stable in cross-winds; something that not all aero bikes can claim. Sophisticated C:68 Twin Mold construction allowed us to incorporate food storage and a drinking system, both of which are accessible from the aero riding position. With completely enclosed cables and hydraulic brake hoses, every single detail is there for one purpose only – to help you ride faster. A SwissSide Hadron Ultimate 800+ wheelset shod with tubeless Schwalbe tyres gets your power down to the ground via Sram's wireless Red AXS 1x12 transmission, and Magura's RT Aero Carbon rim brakes via you the power you need to safely control speed when it matters most. This is a bike that's ready to race and to win. The only question is, are you?

FRAME #Aerium C:68 Monocoque Advanced Twin Mold Technology, Twin Head Tube
SIZE #S, S, M, L
FORK #CUBE Aerium C:68 Aero, Full Integrated

HEADSET #SA Orbit I, 1 1/8" integrated
INTEGRATED BAR/STEM #CUBE C:68 Cockpit System
BAR EXTENSIONS #Profile Design T5+ Carbon
HANDLEBAR TAPE #CUBE Grip Control
REAR DERAILLEUR #Sram Red eTap AXS™, 12-Speed
SHIFTERS #Sram Red eTap AXS™ Blips
SHIFT/ BRAKE LEVERS #Sram Red eTap AXS™ Clics
BRAKE SYSTEM #Magura RT Aero Carbon, Hydr. Rim Brake
CRANKSET #Sram Red D1 Aero Power Meter, 48T, 170mm [XS/S/M], 172.5mm [L]
CASSETTE #Sram XG-1290, 10-28T
WHEELSET #swissSide HADRON Ultimate 800+
TYRES #Schwalbe Pro One, Tubeless Easy, 25-622
SADDLE #Fizik Arione 00 Carbon
SEAT POST #CUBE Aerium C:68 Aero
SEATCLAMP #CUBE Aerium Integrated
EQUIPMENT #CUBE Concept Front Hydration / Concept Gear Unit

WEIGHT #9 kg

SPARE PARTS#
10066 CUBE Hanger Aerium MY18
12810 CUBE Hydration Set Aerium C:68 [2018]
12811 CUBE Storage Box Set Aerium C:68 [2018-2020]

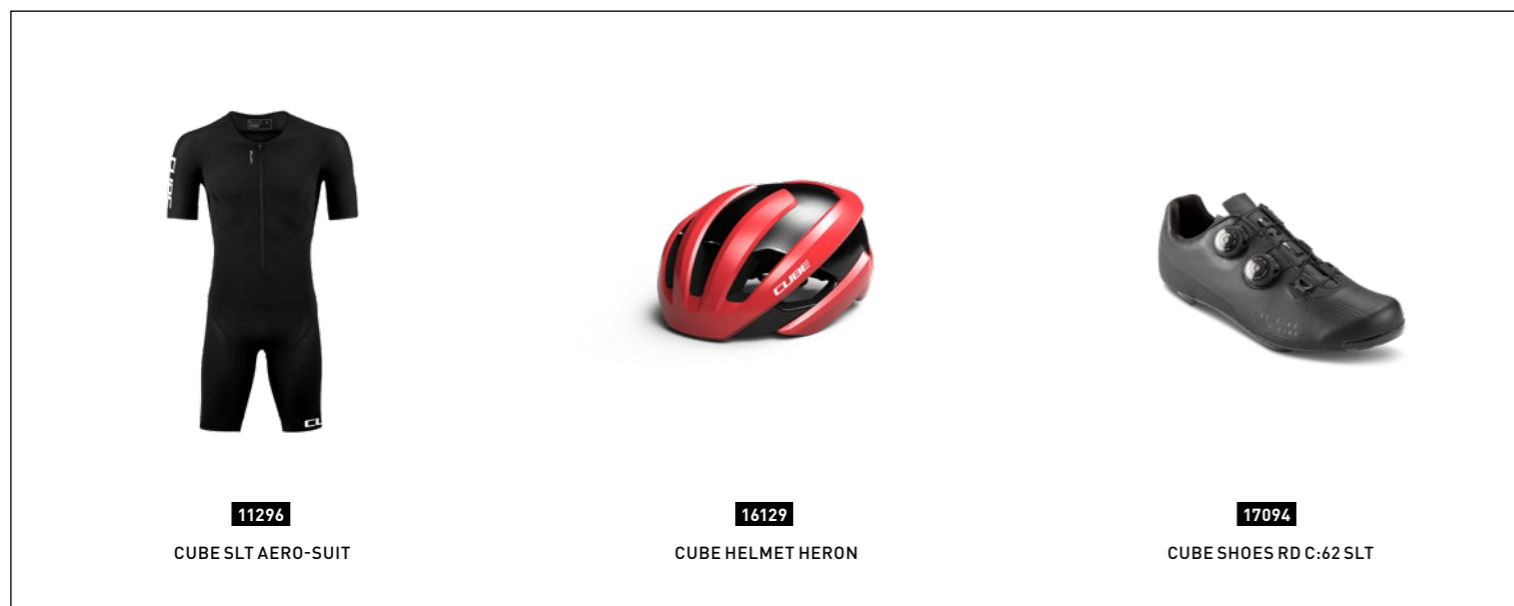

11296
CUBE SLT AERO-SUIT

16129
CUBE HELMET HERON

17094
CUBE SHOES RD C:62 SLT

AERIUM C:68 SLT

386310 HIGH carbon'n'red

386300 LOW carbon'n'red



When you've put in the hours on your training, you'll want a bike that's capable of making the best of your efforts. The Aerium C:68 SLT is that bike – utterly uncompromising in both design and execution to match your uncompromising approach to racing. Developed in conjunction with the aerodynamics specialists at SwissSide, our engineering team began by ditching UCI regulations and setting a new goal: sheer, unadulterated speed, with no design limits. Using a combination of sophisticated computer modelling, wind tunnel testing and real-world data-logging, the result is a bike that out-performs all its competitors in our tests. It slices through the air thanks to its frontal area-reducing dropped seat stays and unique slotted head tube design. It's even stable in cross-winds; something that not all aero bikes can claim. Sophisticated C:68 Twin Mold construction allowed us to incorporate food storage and a drinking system, both of which are accessible from the aero riding position. With completely enclosed cables and hydraulic brake hoses, every single detail is there for one purpose only – to help you ride faster. A DT Swiss 1100 DICUT wheelset shod with tubeless Schwalbe tyres gets your power down to the ground via Sram's wireless Red AXS 2x12 transmission, and Magura's RT Aero Carbon rim brakes give you the power you need to safely control speed when it matters most. This is a bike that's ready to race and to win. The only question is, are you?

FRAME #Aerium C:68 Monocoque Advanced Twin Mold Technology, Twin Head Tube
SIZE #S, S, M, L
FORK #CUBE Aerium C:68 Aero, Full Integrated

HEADSET #SA Orbit I, 1 1/8" integrated
INTEGRATED BAR/STEM #CUBE C:68 Cockpit System
BAR EXTENSIONS #Profile Design T5+ Carbon
HANDLEBAR TAPE #CUBE Grip Control
REAR DERAILLEUR #Sram Red eTap AXS™, 12-Speed
SHIFTERS #Sram Red eTap AXS™ Blips
FRONT DERAILLEUR #Sram Red eTap AXS™
SHIFT/ BRAKE LEVERS #Sram Red eTap AXS™ Clicks
BRAKE SYSTEM #Magura RT Aero Carbon, Hydr. Rim Brake
CRANKSET #Sram Red D1, 50x37T, 170mm (XS/S/M), 172.5mm (L)
CASSETTE #Sram XG-1290, 10-26T
CHAIN #Sram Red D1
WHEELSET #DT Swiss ARC 1100 DICUT Carbon 80
TYRES #Conti Grand Prix 5000 Kevlar, 25-622
SADDLE #Fizik Arione 00 Carbon
SEAT POST #CUBE Aerium C:68 Aero
SEATCLAMP #CUBE Aerium Integrated
EQUIPMENT #CUBE Concept Front Hydration / Concept Gear Unit

WEIGHT #2,2 kg

SPARE PARTS
10066 CUBE Hanger Aerium MY18
10328 CUBE Headset Orbit I with Carbon Cap
12810 CUBE Hydration Set Aerium C:68 [2018]

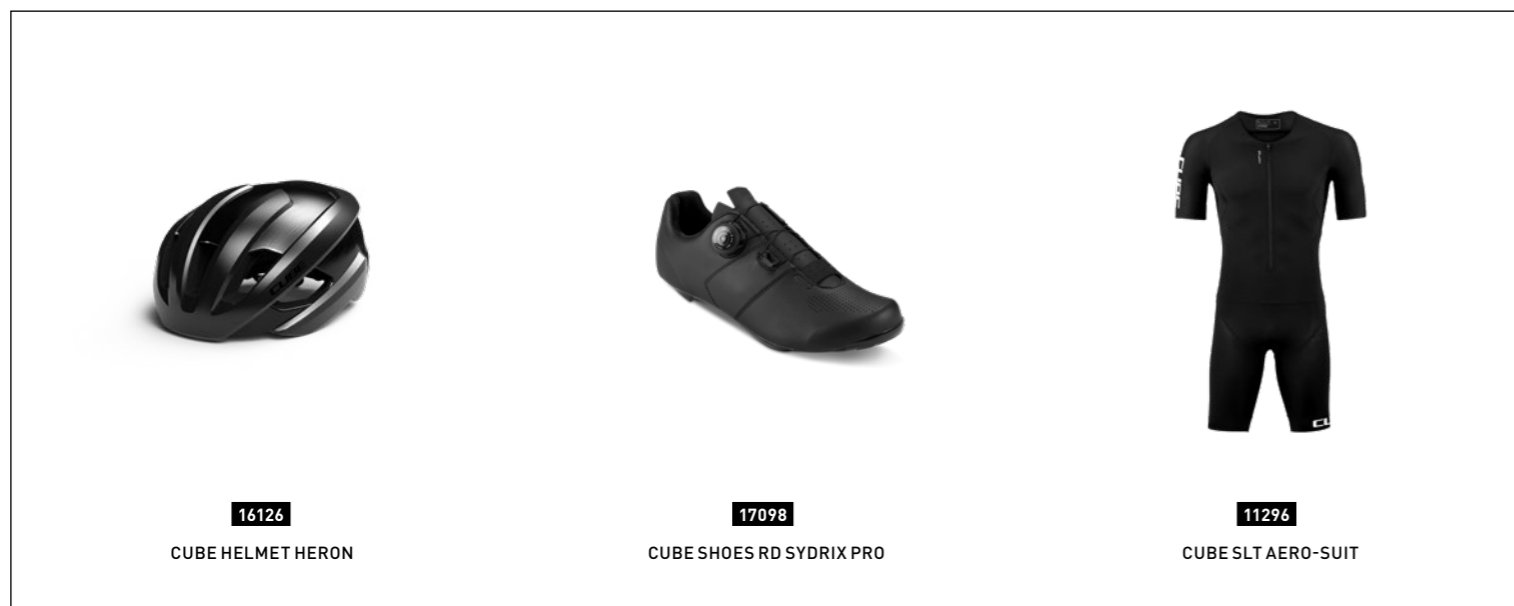

16126
CUBE HELMET HERON

17098
CUBE SHOES RD SYDRIX PRO

11296
CUBE SLT AERO-SUIT

AERIUM C:68 SL

386210 HIGH carbon'n'grey

386200 LOW carbon'n'grey



If you're looking to test your limits and leave the competition behind, the Aerium C:68 SL could well be the perfect tool for the job. Developed in conjunction with the aerodynamics and Formula One specialists at SwissSide, this no-holds-barred speed machine leaves UCI regulations behind in the quest for ultimate performance. Wind tunnel testing, real world data-logging and fastidious attention to detail make this the fastest triathlon bike currently available, according to our testing. And it's not just slippery through the air ahead – it's also remarkably stable in crosswinds and turbulence, giving it impressive stability in real world riding conditions. Low seat stays help to reduce the frontal area, while the slotted head tube acts as a spoiler. The hydraulic brake system, developed in conjunction with Magura, is designed for quick wheel changes and easy adjustment, with all cables and hoses hidden away. A dedicated food storage and hydration setup is part of the package, allowing you to refuel and rehydrate without moving from the aero position. Equipped with Sram's Force AXS wireless 2x12 transmission, it's everything you need to set new personal records – and get your competition worried.

FRAME #Aerium C:68 Monocoque Advanced Twin Mold Technology, Twin Head Tube
SIZE #S, S, M, L
FORK #CUBE Aerium C:68 Aero, Full Integrated

HEADSET #SA Orbit I, 1 1/8" integrated
INTEGRATED BAR/STEM #CUBE C:68 Cockpit System
BAR EXTENSIONS #Profile Design T5+ Carbon
HANDLEBAR TAPE #CUBE Grip Control
REAR DERAILLEUR #Sram Force eTap AXS™, 12-Speed
SHIFTERS #Sram Red eTap AXS™ Blips
FRONT DERAILLEUR #Sram Force eTap AXS™
SHIFT/ BRAKE LEVERS #Sram Red eTap AXS™ Clics
BRAKE SYSTEM #Magura RT Aero Carbon, Hydr. Rim Brake
CRANKSET #Sram Force D1, 48x35T, 170mm (XS/S/M), 172.5mm (L)
CASSETTE #Sram Force XG-1270, 10-26T
CHAIN #Sram Force D1
WHEELSET #ulcrum Racing 44 Aero C17, QR/QR
TYRES #Conti Grand Prix 5000 Kevlar, 25-622
SADDLE #Fizik Arione R7
SEAT POST #CUBE Aerium C:68 Aero
SEATCLAMP #CUBE Aerium Integrated
EQUIPMENT #CUBE Concept Front Hydration / Concept Gear Unit

WEIGHT #6,6 kg

SPARE PARTS#
10066 CUBE Hanger Aerium MY18
10328 CUBE Headset Orbit I with Carbon Cap
12811 CUBE Storage Box Set Aerium C:68 [2018-2020]

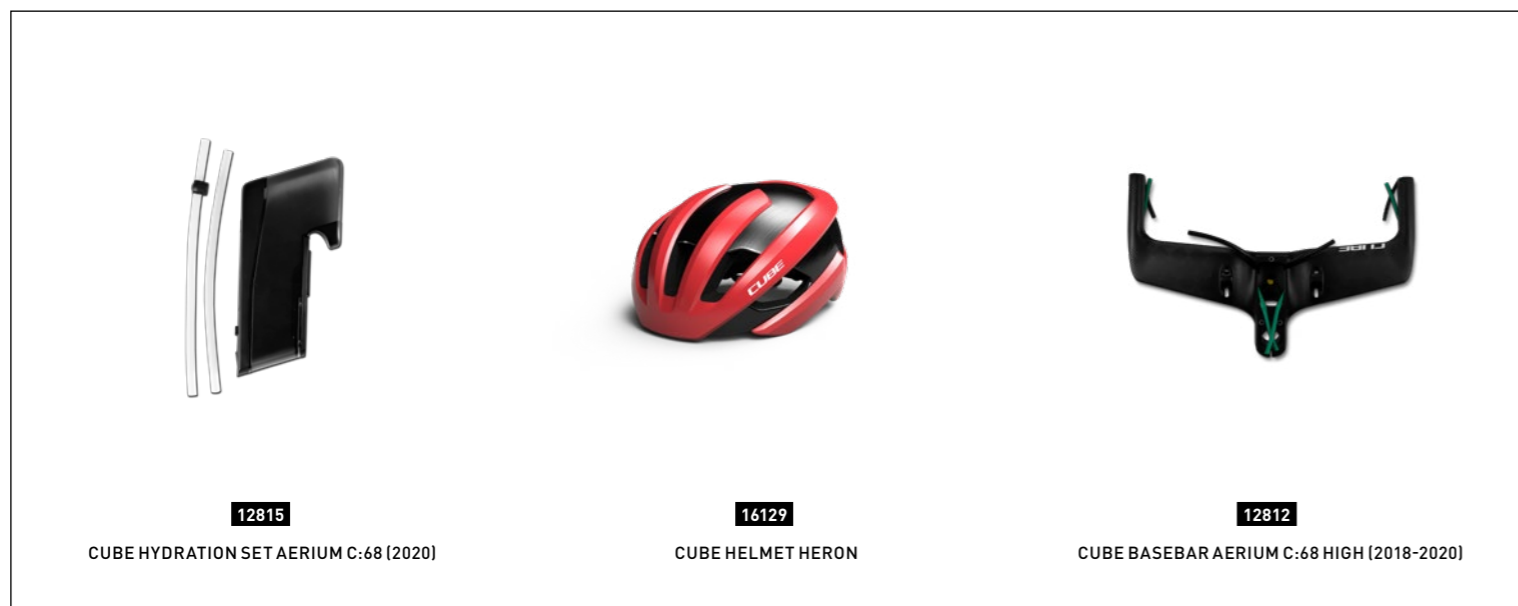

12815
CUBE HYDRATION SET AERIUM C:68 (2020)

16129
CUBE HELMET HERON

12812
CUBE BASEBAR AERIUM C:68 HIGH (2018-2020)

AERIUM C:68 FRAMESET

386410 HIGH carbon'n'red
386400 LOW carbon'n'red



You've perfected your training plan, scheduled your race calendar and collected a selection of the finest components for your dream build. The only thing that's missing – the thing that's needed to complete your perfect triathlon bike – is the ideal frame. And that's where the Aerium C:68 comes in. Developed as a pure, UCI regulation-free tri speed machine with help from the aero experts at SwissSide, we've put as much into this frame as you have into your own performance. We listened to feedback from pro and amateur athletes, pored over the results of endless simulations, and put in hours of wind tunnel testing and real-world data-logging. The result is the fastest triathlon frame that we've ever tested, period – and that includes our competition. The unique slotted head tube design acts as a spoiler, minimising the effects of crosswinds as well as reducing drag. Low seat stays continue the slippery theme, reducing the frame's frontal area for minimal wind resistance, while premium C:68 carbon and advanced Twin Mold construction ensures low weight and fantastic torsional rigidity. We even included food storage and hydration systems that are accessible from the aero tuck, so you can refuel and rehydrate at full pelt. Add it all up and it's easy to see that we've left no stone unturned in our quest for ultimate speed. Don't you owe it to yourself to realise your true potential?

FRAME#Aerium C:68 Monocoque Advanced Twin Mold Technology, Twin Head Tube
SIZE#S, S, M, L
FORK#CUBE Aerium C:68 Aero, Full Integrated

INTEGRATED BAR/STEM#CUBE C:68 Cockpit System
BAR EXTENSIONS#Profile Design T5+ Carbon
BRAKE SYSTEM#Magura RT Aero Carbon, Hydr. Rim Brake
SEAT POST#CUBE Aerium C:68 Aero
EQUIPMENT#CUBE Concept Front Hydration / Concept Gear Unit

WEIGHT#5,5 kg

SPARE PARTS#
10066 CUBE Hanger Aerium MY18
10328 CUBE Headset Orbit I with Carbon Cap
12814 CUBE Seatpost Aerium C:68 [2018-2020]

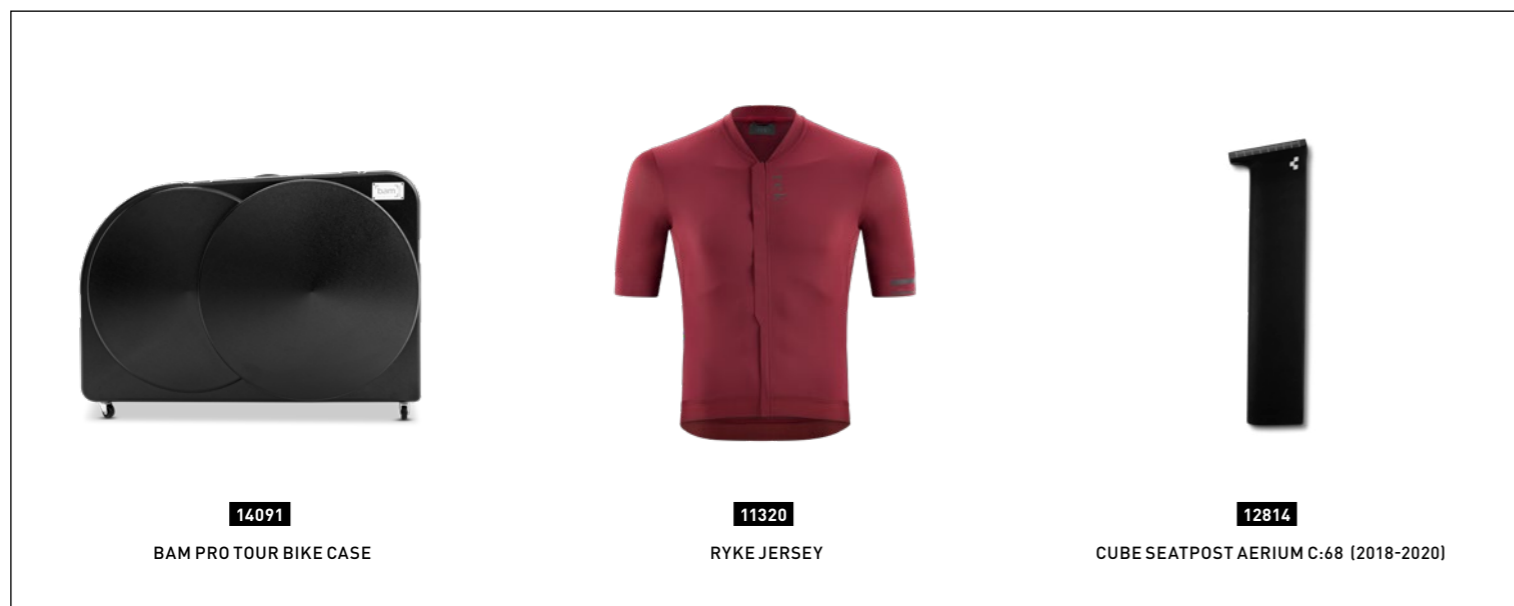

14091
BAM PRO TOUR BIKE CASE



11320
RYKE JERSEY



12814
CUBE SEATPOST AERIUM C:68 [2018-2020]

AERIUM C:68 TT SL

386110 HIGH carbon 'n' white
386100 LOW carbon 'n' white



We're proud of our Aerium triathlon bikes. They're the fastest of their kind on the market, and that's testament to the efforts of our engineers. But what if you want to race time trials on a UCI-compliant machine? Well, we've thought of that too. Meet the all new Aerium C:68 TT – a wind-cheating, PB-busting race bike designed to be the fastest a UCI frame can possibly be. Although it's based on the experience and technology we used to develop the Aerium, the TT is a completely fresh design from the bottom bracket up. Working with the UCI regulations to ensure full compliance, our engineers began with a completely new set of Computer Fluid Dynamics calculations, then tested the results in the wind tunnel. Every single profile of the frame has been changed from the original Aerium, and all in the pursuit of ultimate speed. Our C:68 carbon is crafted into a structure that's light, stiff and cuts through the air like a hot knife through butter. Fast-rolling Schwalbe tyres keep you glued to the tarmac, and Shimano's reliable and slick-shifting Ultegra Di2 Disc groupset gives you both motive and stopping power to spare. Because, when you've put in the time to train, refined your technique and ride position and watched what you eat, the last thing you need is for your bike to let you down. The Aerium C:68 TT is your chance to shine. Take it. Pedal hard. And win.

FRAME #Aerium C:68 Monocoque Advanced Twin Mold Technology, Twin Head Tube
SIZE #S, S, M, L
FORK #CUBE Aerium C:68 Aero, Full Integrated

HEADSET #SA Orbit I, 1 1/8" integrated
INTEGRATED BAR/STEM #CUBE C:68 TT Cockpit System
BAR EXTENSIONS #Profile Design T5+ Carbon
HANDLEBAR TAPE #CUBE Grip Control
REAR DERAILLEUR #Shimano Ultegra Di2 RD-8050-DSS, 11-Speed
FRONT DERAILLEUR #Shimano Ultegra Di2 FD-R8050-F
SHIFT/ BRAKE LEVERS #Shimano Dura Ace Di2 SW-R9160 TT
BRAKE SYSTEM #Shimano Dura Ace BR-R9170 (140/140)
CRANKSET #Shimano Ultegra FC-R8000, 53x39T
CASSETTE #Shimano Ultegra CS-R8000, 11-25T
CHAIN #Shimano CN-HG700-11
WHEELSET #Newmen Evolution SL R.32
TYRES #Schwalbe Pro One, Tubeless Easy, 25-622
SADDLE #Fizik Arione R7
SEAT POST #CUBE Aerium C:68 Aero
SEATCLAMP #CUBE Aerium Integrated
EQUIPMENT #CUBE Concept Front Hydration / Concept Gear Unit

WEIGHT #,4 kg

SPARE PARTS
8655 CUBE HANGER_rr-x12-direct-cube
10033 CUBE Disc Brake Pad Shimano XT2000/XTR

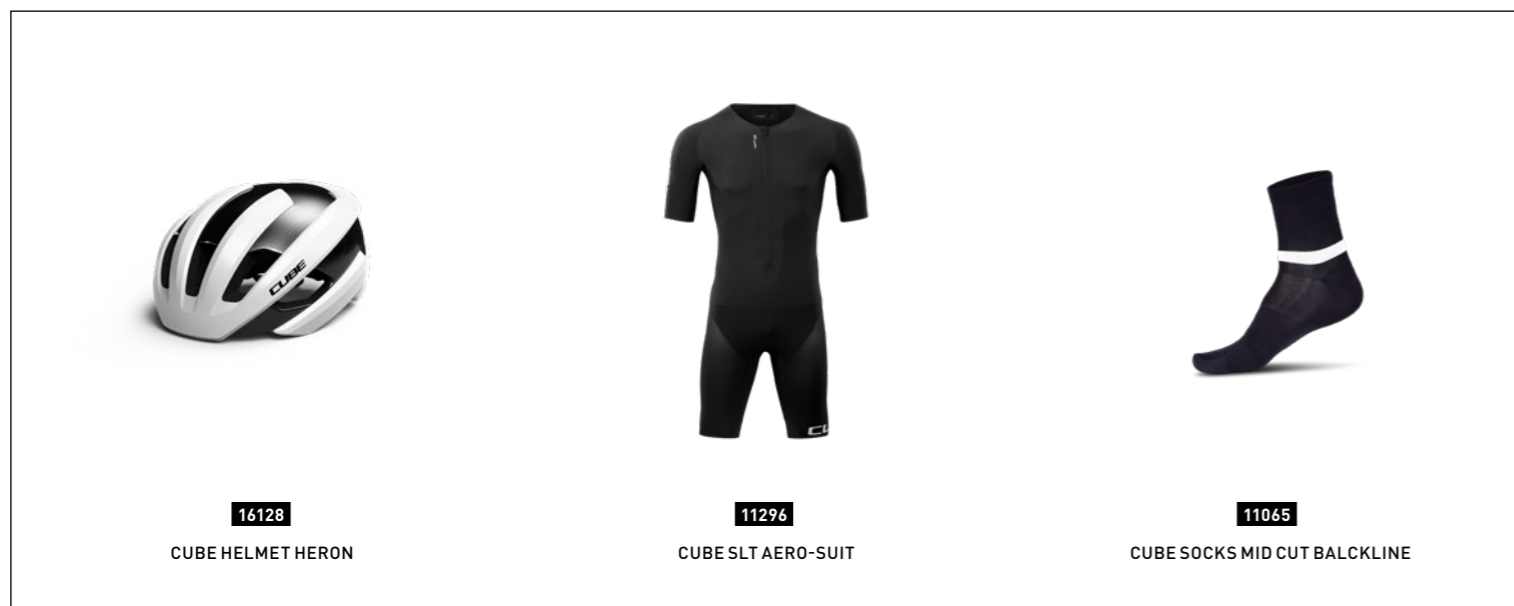

16128
CUBE HELMET HERON

11296
CUBE SLT AERO-SUIT

11065
CUBE SOCKS MID CUT BALCKLINE

AERIUM C:68 TT FRAMESET

386430 HIGH carbon'n'white

386420 LOW carbon'n'white



We're proud of our Aerium triathlon bikes. They're the fastest of their kind on the market, and that's testament to the efforts of our engineers. But what if you want to race time trials on a UCI-compliant machine? Well, we've thought of that too. Meet the all new Aerium C:68 TT – a wind-cheating, PB-busting race bike designed to be the fastest a UCI frame can possibly be. Although it's based on the experience and technology we used to develop the Aerium, the TT is a completely fresh design from the bottom bracket up. Working with the UCI regulations to ensure full compliance, our engineers began with a completely new set of Computer Fluid Dynamics calculations, then tested the results in the wind tunnel. Every single profile of the frame has been changed from the original Aerium, and all in the pursuit of ultimate speed. Our C:68 carbon is crafted into a structure that's light, stiff and cuts through the air like a hot knife through butter. Because, when you've put in the time to train, refined your technique and ride position and watched what you eat, the last thing you need is for your bike to let you down. The Aerium C:68 TT is your chance to shine. Take it. Pedal hard. And win.

FRAME Aerium C:68 Monocoque Advanced Twin Mold Technology, Twin Head Tube
SIZE S, S, M, L
FORK CUBE Aerium C:68 Aero, Full Integrated

INTEGRATED BAR/STEM CUBE C:68 Cockpit System
BAR EXTENSIONS Profile Design T5+ Carbon
HANDLEBAR TAPE CUBE Grip Control
SEAT POST CUBE Aerium C:68 Aero
EQUIPMENT CUBE Concept Front Hydration / Concept Gear Unit

WEIGHT 5,5 kg

SPARE PARTS
8654 CUBE HANGER_mtb/rr-x12-std (18-06267)
8655 CUBE HANGER_rr-x12-direct-cube
12816 CUBE Seatpost Aerium C:68/C:68 TT (2020)



12811 CUBE STORAGE BOX SET AERIUM C:68 (2018-2020)

12818 CUBE BASEBAR AERIUM C:68 TT LOW (2020)

12815 CUBE HYDRATION SET AERIUM C:68 (2020)

AERIUM RACE

386050 carbon'n'blue



Developed to help dedicated athletes pare their times down to the bone, the Aerium Race is a high-performance machine for podium-chasing triathletes and time triallists. One glance will tell you that this is no ordinary bike – we sweated every detail on the frame and components to maximise performance, so you can push yourself harder. With Shimano's Ultegra gears, a CUBE Aerium carbon aero fork and Mavic wheelset, you've everything you need to smash out some new personal bests – and get a foot on the podium. It's the perfect symbiosis of ultimate performance, refined aerodynamics and surprising value. You just ran out of excuses... but you also increased your chances of beating the competition.

-  **FRAME** #Aerium C:68 Monocoque Advanced Twin Mold Technology, Internal Cable Routing
- SIZES** M, L
- FORK** #CUBE Aero Aerium C:68

-  **HEADSET** #SA Orbit I, 1 1/8" integrated
- STEM** #CUBE Aerium C:68 Integrated
- HANDLEBAR** #Profile Svet TT Carbon
- BAR EXTENSIONS** #Profile Design T5+ Carbon
- HANDLEBAR TAPE** #CUBE Grip Control
- REAR DERAILLEUR** #Shimano Ultegra RD-R8000-SS, 11-Speed
- SHIFTERS** #Shimano Dura Ace SL-BSR1, Barend Shifter
- FRONT DERAILLEUR** #Shimano Ultegra FD-R8000-F
- BRAKE SYSTEM** #Aero TTV01 / Shimano 105 BR-5810
- BRAKE LEVERS** #Profile Aero Brake Lever Carbon
- CRANKSET** #Shimano Ultegra FC-R8000, 53x39T, 170mm (S/M), 172.5mm (L)
- CASSETTE** #Shimano Ultegra CS-R8000, 11-25T
- CHAIN** #Shimano CN-HG700-11
- WHEELSET** #Mavic Cosmic Elite, QR/QR
- TYRES** #Conti Grand Sport Race SL, 28x23
- SADDLE** #Fizik Arione R7
- SEAT POST** #CUBE Aero Aerium C:68
- SEATCLAMP** #CUBE Aerium Integrated

 **WEIGHT** #,8 kg

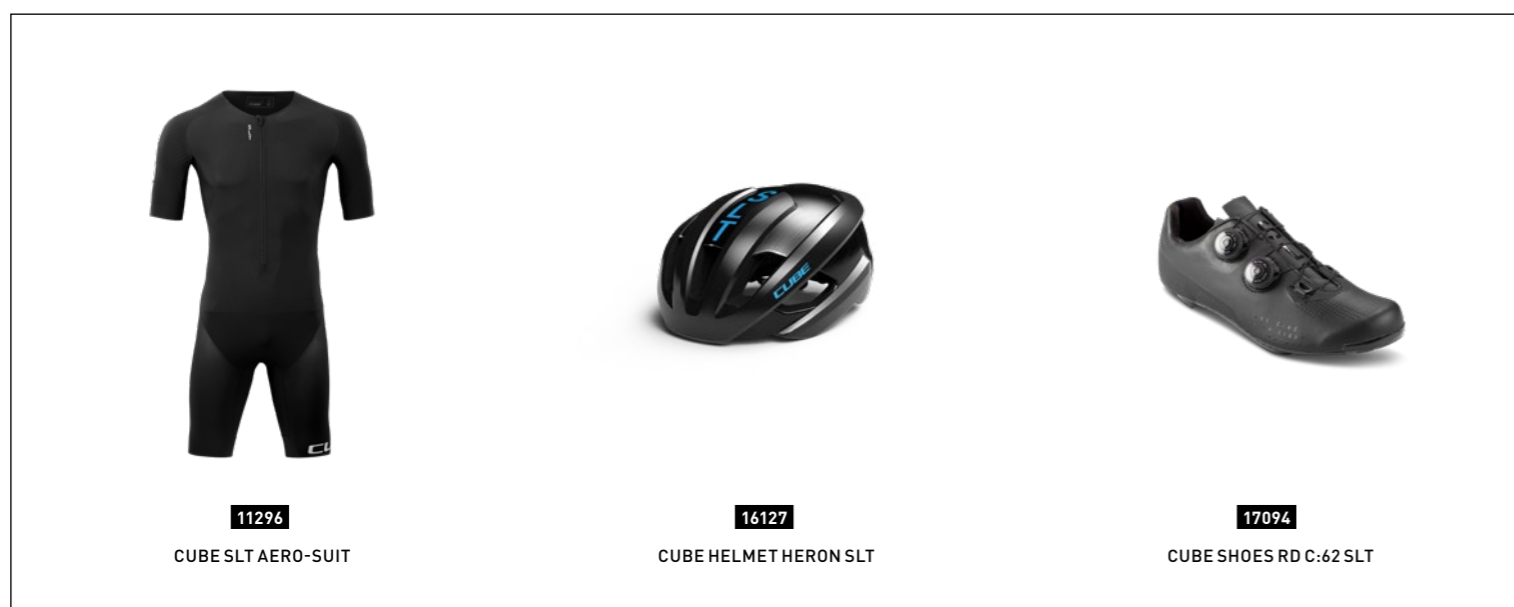

11296
CUBE SLT AERO-SUIT

16127
CUBE HELMET HERON SLT

17094
CUBE SHOES RD C:62 SLT

-  **SPARE PARTS** #
- 10328 CUBE Headset Orbit I with Carbon Cap
- 13553 Inner Tube 28" ROAD SV 60 mm extra light

W O M
E N S
I E E
S R S



LEISURE TOUR SPORT TRAIL

234 **ACCESS** C:62 | 27.5, 29

240 **ACCESS** HPA | 27.5, 29

258 **STING 140** HPC | 27.5

262 **STING 120** HPA | 27.5, 29

268 **AXIAL** C:62

270 **AXIAL** GTC

274 **AXIAL** HPA

282 **NUROAD** HPA



ACCESS

Simplicity is often a virtue. Our elegant, undersated all-rounder has the capability to expand your riding horizons, from scenic trails to cross-country races and everything in-between. Light, svelte and beautifully equipped, there's an Access to suit every woman.

STING 140

Get your shred on! Ain't no mountain high enough to get in the way of the Sting 140 rider. Light, smooth, agile and comfortable enough for all-day riding, our carbon-framed trail-tamer is built to take you further, faster and higher than you thought possible.

STING 120

Make the trail your own. Our Sting 120's wide range of sizes, low weight and easy handling make it the perfect choice for any rider who enjoys expanding her horizons. Smooth out the trail ahead, take on new challenges and tame the mountain - it's all within your reach.

AXIAL

Pure, unadulterated cycling pleasure. The Axial's beauty is more than skin deep, because underneath that sleek exterior is the heart and soul of a thoroughbred. All our road racing experience has gone into this bike to make it fast, comfortable and practically unstoppable.

NUROAD

Nuroad, new road riding experience. The talented lovechild of our cyclocross and road race series, this is a bike that will surprise and delight you. Combining the speed of a tarmac-bred thoroughbred with the resilience and comfort of an off-roader, there are now officially no limits.

FOR us #XC-Queens

Everything we've learnt about building great-handling, lightweight carbon hardtails is ploughed into the Access WS C:62's frame. Built with our C:62 carbon, it also features a short and stiff rear triangle – complete with Boost axle – for efficient pedalling. The result is superb tracking and steering, sharp acceleration and, combined with our Agile Ride Geometry, inspiring handling all round. A PressFit bottom bracket and integrated headset make the most of the weight savings we've finessed, while slim seat stays and a slender 27.2mm seat post help take some of the buzz out of the trail – good news if you like to ride not just hard, but long too. Internal cable routing complements the frame's organic lines, but also keep gear shifts smooth without the need for regular maintenance. We even included an easy upgrade option to a stealth dropper post, so you can keep riding when the trail gets super steep. It's all in the details...



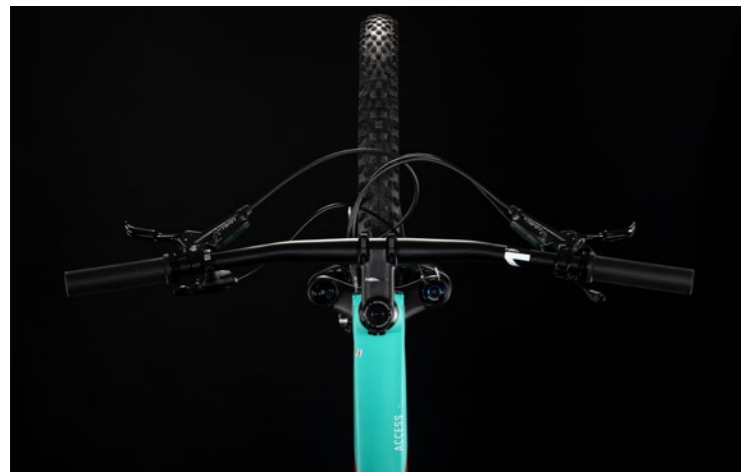

11030
CUBE TEAMLINE WS JERSEY

11034
CUBE TEAMLINE WS BAGGY SHORTS

11070
CUBE GLOVES WS TEAMLINE

How much will a really light hardtail mountain bike set you back? In the case of the Access WS C:62 SL Team, a lot less than you think. This is an unapologetically uncompromising trail-exploring machine. Fast, light, nimble and responsive, every detail is designed to help you extract the absolute maximum from your time on the trail. For example, the short rear end with stiffness-enhancing Boost axle works with the tapered head tube to provide efficient pedalling and accurate steering. Combined with our Agile Ride Geometry, it makes for an inspirational and intuitive ride companion which, thanks to slender seat stays and a narrow 27.2mm seat post, will keep you comfortable as you rack up the miles. On a bike as capable as this, it would have been rude of us not to select the very best components. So that's what we did, beginning with Sram's 1x12 Eagle transmission for exceptional range, low weight and unmatched ease of use. Sram's Level hydraulic disc brakes dish out as much controllable power as you need to keep your speed in check, helped by the light and stiff Fulcrum wheelset and grippy Schwalbe tyres. And the RockShox SID air fork with remote lockout is a superbly accomplished rock swallower. We even included Newmen Evolution cockpit components – and our Size Split system means you're sure to be able to find the perfect fit. The only thing left to do is to decide where you're going to ride next...

FRAME #C:62 Monocoque Advanced Twin Mold Technology, ARG2, Tapered Headtube, PressFit Boost BB, Integrated Cable Routing, Boost 148, Dropper Post Ready
SIZE Size Split: 27.5: 13.5" // 29: 15", 17", 19"
FORK #RockShox Sid Select+, 15x110mm, Tapered, 100mm, Oneloc

HEADSET #SA Orbit I-t, Integrated, Top 1 1/8", Bottom 1 1/2"
STEM #Newmen Evolution 318.4, 31.8mm
HANDLEBAR #Newmen Evolution 318.10, 720mm
GRIPS #CUBE Race SL Grip 29.5mm, 1-Clamp
REAR DERAILLEUR #Sram GX Eagle™, 12-Speed
SHIFTERS #Sram GX Eagle™ Trigger
BRAKE SYSTEM #Sram Level TL, Hydr. Disc Brake (180/160)
CRANKSET #Sram X1 Eagle™ Carbon DUB 32T, 175mm (Smallest Size 170mm)
CASSETTE #Sram XG-1275, 10-50T
CHAIN #Sram GX Eagle™
WHEELSET #Fulcrum Red Zone 700 Boost, 28/28 Spokes, 15x110mm/12x148mm, Tubeless Ready
FRONT TIRE #Schwalbe Rocket Ron, Addix Performance, Kevlar, 2.25
REAR TIRE #Schwalbe Racing Ralph, Addix Performance, Kevlar, 2.25
SADDLE #Natural Fit Venec WS
SEAT POST #Newmen Evolution, 27.2mm
SEATCLAMP #CUBE Varioclose, 31.8mm

WEIGHT #0,4 kg

SPARE PARTS#
8651 CUBE HANGER_mtb-x12-std-2020 (18-05516)
10339 CUBE Headset Orbit I-T + 1 1/8 crown race
13547 Inner Tube 27,5"/29" MTB SV 40 mm extra light

ACCESS WS C:62 PRO

326200 lightblue'n'lime



When your riding ambitions stretch further than your local trail centre, you'll want a bike that can rise to the challenge. That's why we developed the Access WS C:62 Pro – a carbon-framed hardtail for women who live and ride adventurously. You'll love the sleek looks and light weight, because everything we've learnt about building great-handling, lightweight carbon bikes is ploughed into this svelte trail machine. Our engineers started with premium C:62 carbon, then built a chassis with a short and stiff rear end for great handling and incredible efficiency, slender seat stays and narrow 27.2mm seat post for comfort and Agile Ride Geometry so you can get the best out of your skills on the trail. But it isn't just great looking – its beauty is far more than skin deep. Carefully selected components include the smooth-shifting, ultra-wide-ranging Shimano 1x12 gears – which put every climb within reach. Powerful Shimano hydraulic disc brakes ensure you can keep your speed in check no matter what the weather or trail conditions, while grippy and fast-rolling Schwalbe tyres work in harmony with the RockShox Judy Silver air suspension fork to smooth the trail ahead. And, naturally, it's available with our Size Split system blending wheel diameter and frame size, so that every rider can find her perfectly tailored fit. Low weight, beautiful design and fantastic performance: you really can have it all with the Access WS C:62 Pro.

FRAME #C:62 Monocoque Advanced Twin Mold Technology, ARG2, Tapered Headtube, PressFit Boost BB, Integrated Cable Routing, Boost 148, Dropper Post Ready
SIZE Size Split: 27.5" / 13.5" // 29" / 15", 17", 19"
FORK #RockShox Judy Silver TK Air, 15x110mm, Tapered, 100mm

HEADSET #SA Orbit I-t, Integrated, Top 1 1/8", Bottom 1 1/2"
STEM #CUBE Performance Stem Pro, 31.8mm
HANDLEBAR #CUBE Flat Race Bar, 720mm
GRIPS #CUBE Performance Grip
REAR DERAILLEUR #Shimano XT RD-M8100-SGS, ShadowPlus, 12-Speed
SHIFTERS #Shimano SLX SL-M7100-I Direct Attach
BRAKE SYSTEM #Shimano XT BR-M8100, Hydr. Disc Brake (180/160)
CRANKSET #Shimano FC-MT610, 32T, Boost, 175mm (Smaller Sizes 170mm)
CASSETTE #Shimano SLX CS-M7100, 10-51T
CHAIN #Shimano CN-M7100
RIMS #CUBE MD21, 32H, Disc, Tubeless Ready
FRONT HUB #Shimano HB-MT400-B, 15mm, Boost, Centerlock
REAR HUB #Shimano FH-MT510-B, Boost, Through Axle, Centerlock
TYRES #Schwalbe Smart Sam, Active, 2.25
SADDLE #Natural Fit Venec WS
SEAT POST #CUBE Performance Post, 27.2mm
SEATCLAMP #CUBE Varioclose, 31.8mm

WEIGHT #1,9 kg

SPARE PARTS
8651 CUBE HANGER_mtb-x12-std-2020 (18-05516)
10339 CUBE Headset Orbit I-T + 1 1/8 crown race
13547 Inner Tube 27,5"/29" MTB SV 40 mm extra light



10779
CUBE AM WS JERSEY

10700
CUBE AM WS BAGGY SHORTS

40396
CUBETOOL 20 IN 1

FOR us #OutdoorWomen

Frame-building technologies are evolving constantly, but our engineers are at the top of their game. The Access WS features a PressFit bottom bracket and tapered head tube, for added pedalling efficiency and steering precision. Agile Ride Geometry means you can rely on the kind of balanced-but-lively handling for which CUBE is renowned – you can take it easy or go full throttle, whatever floats your boat. From the safety point of view, you can rest assured that it's passed our stringent in-house testing for strength and durability. Mechanically formed top and down tubes with complex profiles form a rigid, strong and light backbone built from 6061 aluminium, while internal cable routing and tidy details like the integrated rear disc mount simply add to the impression that this is a finely crafted frame. And thanks to our durable, multi-layer paint finish, your Access WS will keep its good looks for years to come, no matter how hard you ride.



ACCESS WS SL

325600 iridium'n'aqua



ACCESS WS SL

325610 mint'n'grey

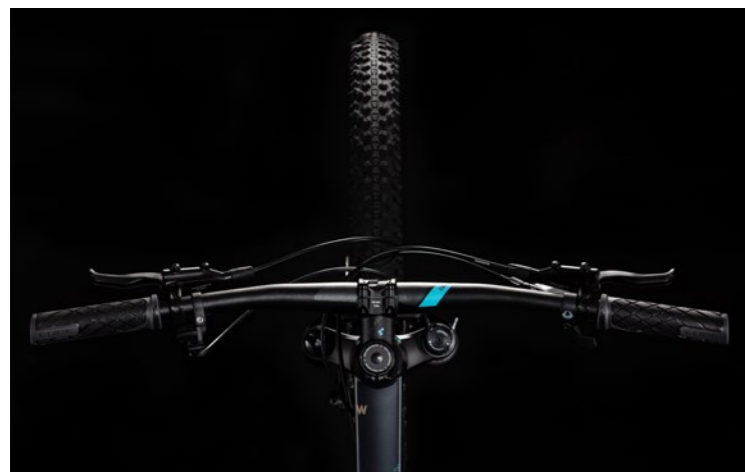

What fires you up? For us it's making the best possible bikes – and the Access WS SL is a great example. Designed and built so that you can push your boundaries out on the trail, it's the inspiration you need to ride further, faster and in greater comfort than before. With a frame that channels everything we know about building great hardtails into a Size Split format that's designed specifically so that every woman can find her perfect fit, we've worked hard to build a bike that's light, fast, safe, reliable... and above all, easy to live with. Agile Ride Geometry means you can rely on the kind of balanced-but-lively handling for which CUBE is renowned – you can take it easy or go full throttle, whichever floats your boat. From the safety point of view, you can rest assured that it's passed our stringent in-house testing for strength and durability. Sram 1x12 Eagle components put every climb within reach with the absolute minimum of fuss, while powerful Shimano hydraulic disc brakes with light, grippy Schwalbe tyres and a RockShox Recon Silver air fork – with remote lockout – ensure you're always in full control. Whatever your passion – race or explore – you'll get more from your riding with the Access WS SL.

FRAME Aluminium Lite, Triple Butted, Advanced Hydroforming, Internal Cable Routing, Easy Mount Kickstand Ready, Tapered Headtube, Press Fit BB
SIZE Size Split: 27.5": 13.5", 16" // 29": 17", 19"
FORK RockShox Recon Silver TK Air, 100mm, PopLoc

HEADSET CUBE No.10 Semi-integrated
STEM CUBE Performance stem Pro, 31.8mm
HANDLEBAR CUBE Rise Trail Bar, 680mm
GRIPS CUBE Performance Grip
REAR DERAILLEUR Sram NX Eagle™, 12-Speed
SHIFTERS Sram NX Eagle™ Trigger
BRAKE SYSTEM Shimano BR-MT400, Hydr. Disc Brake (180/160)
CRANKSET Sram Stylo Eagle™ DUB, 32T, 170mm
CASSETTE Sram XG-1230, 11-50T
CHAIN Sram NX Eagle™
RIMS CUBE SD20, 32H, Disc
FRONT HUB Shimano Deore HB-M6000, Centerlock
REAR HUB Shimano Deore FH-M6000, Centerlock
TYRES Schwalbe Smart Sam, Active, 2.25
PEDALS CUBE PP MTB
SADDLE Natural Fit Venec Lite WS
SEAT POST CUBE Performance Post, 27.2mm
SEATCLAMP CUBE Varioclose, 31.8mm

WEIGHT #3,2 kg

SPARE PARTS#
10148 CUBE Hanger #148 short version
10324 CUBE Headset Orbit Z
13456 RFR Seatclamp with Quick Release 31,8 mm
13543 Inner Tube 27,5"/29" MTB AGV 40 mm



11291
CUBE TOUR WS JERSEY

11290
CUBE TOUR WS BAGGY SHORTS

12109
CUBE BACKPACK EDGE TRAIL

ACCESS WS RACE

325500 black 'n' green



ACCESS WS RACE

325510 grey 'n' lime



You might guess from the Access WS Race's name that it's got speed in its genes – and you'd be right. But you don't need to go racing to get the benefit from its lightweight frame, intuitive handling or smooth, reliable components. It's a bike that's designed for any woman with an adventurous streak, an urge to push her boundaries or to go in search of new personal goals. With the benefit of our Size Split system – so any rider can find her perfect fit – and a design team dedicated to ensuring the best possible handling, comfort and safety, it's the perfect tool to help you discover new trails to explore. The Suntour air suspension fork features easy setup, low weight and smooth, bump-smoothing performance that improves both comfort and control. The frame uses proprietary technologies like mechanically formed tubes and Compact Agile Ride Geometry to deliver the ideal blend of reassuring stability and inspirational control. And the wide-ranging, smooth-shifting Shimano 2x10 gears put the right gear for any trail literally at your fingertips. Combined with powerful hydraulic disc brakes and light, grippy Schwalbe tyres, it's the perfect setup to keep you in charge, no matter what the conditions. Comfort, control and a whole heap of fun: who said a woman can't have it all?

FRAME Aluminium Lite, AMF, Internal Cable Routing, Easy Mount Kickstand Ready
SIZE Size Split: 27.5: 13.5", 16" // 29: 17", 19"
FORK Suntour XCR32 Air RL Disc, 100mm, Remote Lockout

HEADSET CUBE FPH863, Semi-Integrated
STEM CUBE Performance Stem Pro, 31.8mm
HANDLEBAR CUBE Rise Trail Bar, 680mm
GRIPS CUBE Performance Grip
REAR DERAILLEUR Shimano Deore RD-M6000-DGS, ShadowPlus, 10-Speed
SHIFTERS Shimano Deore SL-M6000, Rapidfire-Plus
FRONT DERAILLEUR Shimano Deore FD-M6025-H, Downswing, 31.8mm Clamp
BRAKE SYSTEM Shimano BR-MT200, Hydr. Disc Brake (180/160)
CRANKSET Shimano FC-MT500-2, 36x26T, 170mm
CASSETTE Shimano Deore CS-HG500, 11-42T
CHAIN Shimano CN-HG54
RIMS CUBE SD20, 32H, Disc
FRONT HUB Shimano HB-M3050, Centerlock
REAR HUB Shimano FH-M3050, Centerlock
TYRES Schwalbe Smart Sam, Active, 2.25
PEDALS CUBE PP MTB
SADDLE Natural Fit Venec Lite WS
SEAT POST CUBE Performance Post, 27.2mm
SEATCLAMP CUBE Varioclose, 31.8mm

WEIGHT 3,4 kg



11560 NATURAL FIT SADDLE VENEC WS

93150 ACID PEDALS FLAT C3-ZP

13111 NATURAL FIT GRIPS ALL TERRAIN

SPARE PARTS#
10025 CUBE Disc Brake Pad Shimano Deore BR-M505/15/525/445/446
10149 CUBE Hanger #149 long version
10324 CUBE Headset Orbit Z
13543 Inner Tube 27,5"/29" MTB AGV 40 mm

ACCESS WS PRO ALLROAD

325450 greyblue'n'apricot



A mountain bike is a versatile beast. And that got us thinking – what if we could build a great mountain bike that could also slot easily into your daily routine? Meet the Access WS Pro Allroad – a crossover bike that combines the best of go-anywhere ruggedness with a dose of urban practicality. The included mudguards and luggage carrier attach almost seamlessly to the frame via cunningly designed mounting points, while the kickstand and built-in lighting system ensure that you'll always be at home on the city streets. But it's not just about being practical, because underneath the no-nonsense design is an accomplished off-roader with everything you need to have fun. Light and grippy Schwalbe tyres combine with the Suntour fork – with remote lockout – and powerful Shimano hydraulic disc brakes to give you all the comfort and control you need, whether you're tackling potholed streets or a bumpy forest trail. Smooth-shifting and wide-ranging 27-speed Shimano gears will help you tackle even the steepest of climbs, and everything from saddle to stem, grips and handlebar has been selected to fit the female form for day-long comfort. Add it all up, and the Access WS Pro Allroad looks very much like all the bike you're ever likely to need.

FRAME Aluminium Lite, AMF, Internal Cable Routing, Easy Mount Kickstand Ready
SIZE Size Split: 27.5: 13.5", 16" // 29: 17", 19"
FORK Suntour XCM RL Disc, 100mm, Remote Lockout

HEADSET CUBE FPH863, Semi-Integrated
STEM CUBE Performance Stem Pro, 31.8mm
HANDLEBAR CUBE Rise Trail Bar, 680mm
GRIPS CUBE Performance Grip
REAR DERAILLEUR Shimano Deore RD-M592, 9-Speed
SHIFTERS Shimano SL-M4000, Rapidfire-Plus
FRONT DERAILLEUR Shimano FD-M2000, Downswing, 31.8mm Clamp
BRAKE SYSTEM Shimano BR-MT200, Hydr. Disc Brake (160/160)
CRANKSET Shimano FC-MT101, 40x30x22T, 175mm
CASSETTE Shimano CS-HG400, 12-36T
CHAIN Shimano HG53
RIMS CUBE SD20, 32H, Disc
FRONT HUB Shimano DH-3D37, Hub Dynamo, QR, Centerlock
REAR HUB Shimano FH-TX505, QR, Centerlock
TYRES Schwalbe Smart Sam, Active, 2.25
PEDALS CUBE PP MTB
SADDLE Natural Fit Venec Lite WS
SEAT POST CUBE Performance Post, 27.2mm
SEATCLAMP CUBE Varioclose, 31.8mm
FRONT LIGHT relock LS592
REAR LIGHT relock LS 613 Parklight
KICKSTAND CUBE Stand Pro, Adjustable
MUDGUARDS CID 60
BELL luvo
CARRIER CID Semi-Integrated Carrier, CID RILink Adapter Compatible and Rail

WEIGHT #6,3 kg

SPARE PARTS#
10025 CUBE Disc Brake Pad Shimano Deore BR-M505/15/525/445/446
10148 CUBE Hanger #148 short version
10324 CUBE Headset Orbit Z
13543 Inner Tube 27,5"/29" MTB AGV 40 mm

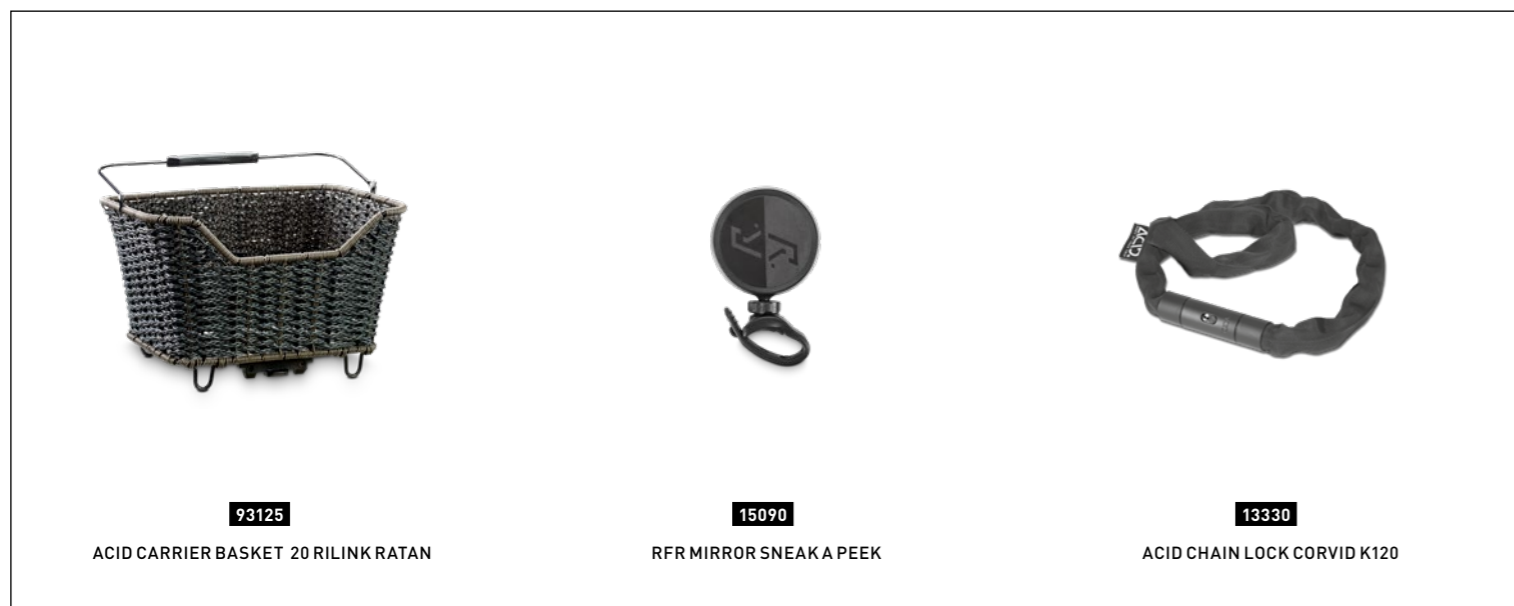

93125 ACID CARRIER BASKET 20 RILINK RATAN

15090 RFR MIRROR SNEAK A PEEK

13330 ACID CHAIN LOCK CORVID K120

ACCESS WS PRO

325400 iridium 'n' deepred



ACCESS WS PRO

325410 titan 'n' mint



When the urge to explore further afield becomes too much to resist, you'll need a partner in crime – or, at the very least, a bike that'll be with you for every turn of the pedals. Have you met the Access WS Pro? It's built for the job. Light, comfortable and well-equipped, it's a bike that's as good to ride as it is to look at. We've built the frame around two different wheel sizes so that every rider can find her perfect fit, from the 13.5in frame with 27.5in wheels to the 19in 29er. Whichever one you choose, the light and grippy Schwalbe Smart Sam 2.25in tyres, combined with the remote lockout-equipped Suntour fork and powerful Shimano hydraulic disc brakes, give you all the comfort and control you need to tackle any road or trail with confidence. Smooth-shifting and wide-ranging Shimano gears will help you tackle even the steepest of climbs, and we selected the rider contact points – like grips, handlebars and saddle – specially to fit the female form. Get inspired and get riding... with the Access WS Pro.

FRAME Aluminium Lite, AMF, Internal Cable Routing, Easy Mount Kickstand Ready
SIZE Size Split: 27.5: 13.5", 16" // 29: 17", 19"
FORK Suntour XCM RL Disc, 100mm, Remote Lockout

HEADSET CUBE FPH863, Semi-Integrated
STEM CUBE Performance Stem Pro, 31.8mm
HANDLEBAR CUBE Rise Trail Bar, 680mm
GRIPS CUBE Performance Grip
REAR DERAILLEUR Shimano Deore RD-M592, 9-Speed
SHIFTERS Shimano SL-M4000, Rapidfire-Plus
FRONT DERAILLEUR Shimano FD-M2000, Downswing, 31.8mm Clamp
BRAKE SYSTEM Shimano BR-MT200, Hydr. Disc Brake (160/160)
CRANKSET Shimano FC-MT100, 40x30x22T, 175mm
CASSETTE Shimano CS-HG400, 12-36T
CHAIN Shimano HG53
RIMS CUBE SD20, 32H, Disc
FRONT HUB Shimano HB-TX505, QR, Centerlock
REAR HUB Shimano FH-TX505, QR, Centerlock
TYRES Schwalbe Smart Sam, Active, 2.25
PEDALS CUBE PP MTB
SADDLE Natural Fit Venec Lite WS
SEAT POST CUBE Performance Post, 27.2mm
SEATCLAMP CUBE Varioclose, 31.8mm

WEIGHT 3,6 kg

SPARE PARTS#
10148 CUBE Hanger #148 short version
10324 CUBE Headset Orbit Z
13543 Inner Tube 27,5"/29" MTB AGV 40 mm
10025 CUBE Disc Brake Pad Shimano Deore BR-M505/15/525/445/446

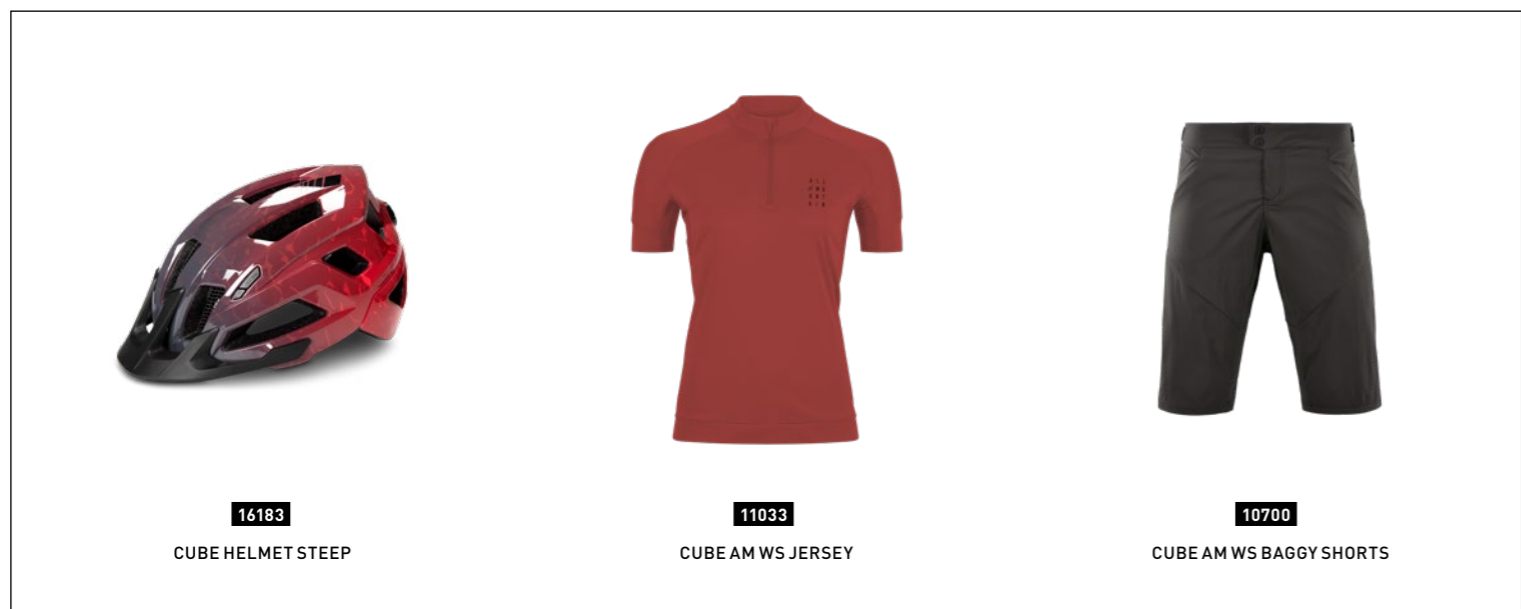

16183
CUBE HELMET STEEP



11033
CUBE AM WS JERSEY



10700
CUBE AM WS BAGGY SHORTS

ACCESS WS EXC

325300 black 'n' sesam



ACCESS WS EXC

325310 poppyred 'n' coral



If you're looking for just the right blend of comfort and performance in a mountain bike, the Access WS Exc will fit the bill very nicely. Featuring our well-regarded Access frame – with Size Split system so that every rider can find her perfect fit – it also boasts a great selection of components chosen for their performance, ease of use and reliability. For example, the Suntour suspension fork doesn't just improve comfort and control, but also features a remote lockout for bob-free climbing. The wide-ranging 24-speed Shimano transmission puts the right gear for any occasion at your fingertips, while the Shimano hydraulic disc brakes ensure you're always in full control, no matter what the weather throws at you. Our Compact Agile Ride Geometry is designed to make your Access WS Exc nimble and confidence-inspiring, and of course all the rider contact points are designed for women riders to ensure the best possible fit and all-day comfort. We like to think we've thought of everything, so that you can simply concentrate on enjoying the ride.

FRAME Aluminium Lite, AMF, Internal Cable Routing, Easy Mount Kickstand Ready
SIZE Size Split: 27.5: 13.5", 16" // 29: 17", 19"
FORK Suntour XCM RL Disc, 100mm, Remote Lockout

HEADSET CUBE FPH863, Semi-Integrated
STEM CUBE Performance Stem, 31.8mm
HANDLEBAR CUBE Rise Trail Bar, 680mm
GRIPS CUBE Performance Grip
REAR DERAILLEUR Shimano RD-M360, 8-Speed
SHIFTERS Shimano SL-M315, Rapidfire-Plus
FRONT DERAILLEUR Shimano FD-M310, Dual Pull, 31.8mm
BRAKE SYSTEM Shimano BR-MT200, Hydr. Disc Brake (160/160)
CRANKSET Shimano FC-TX801, 42x32x22T, 170mm
CASSETTE Shimano CS-HG318, 11-34T
CHAIN MC CUB.3
RIMS CUBE SD20, 32H, Disc
FRONT HUB CUBE Disc Hub, 6-Bolt
REAR HUB CUBE Disc Hub, 6-Bolt
TYRES Schwalbe Smart Sam, Active, 2.1
PEDALS CUBE HPP MTB
SADDLE Natural Fit Venec Lite WS
SEAT POST CUBE Performance Post, 27.2mm
SEATCLAMP CUBE Varioclose, 31.8mm

WEIGHT 3,7 kg

SPARE PARTS#
10025 CUBE Disc Brake Pad Shimano Deore BR-M505/15/525/445/446
10148 CUBE Hanger #148 short version
10324 CUBE Headset Orbit Z
13543 Inner Tube 27,5"/29" MTB AGV 40 mm

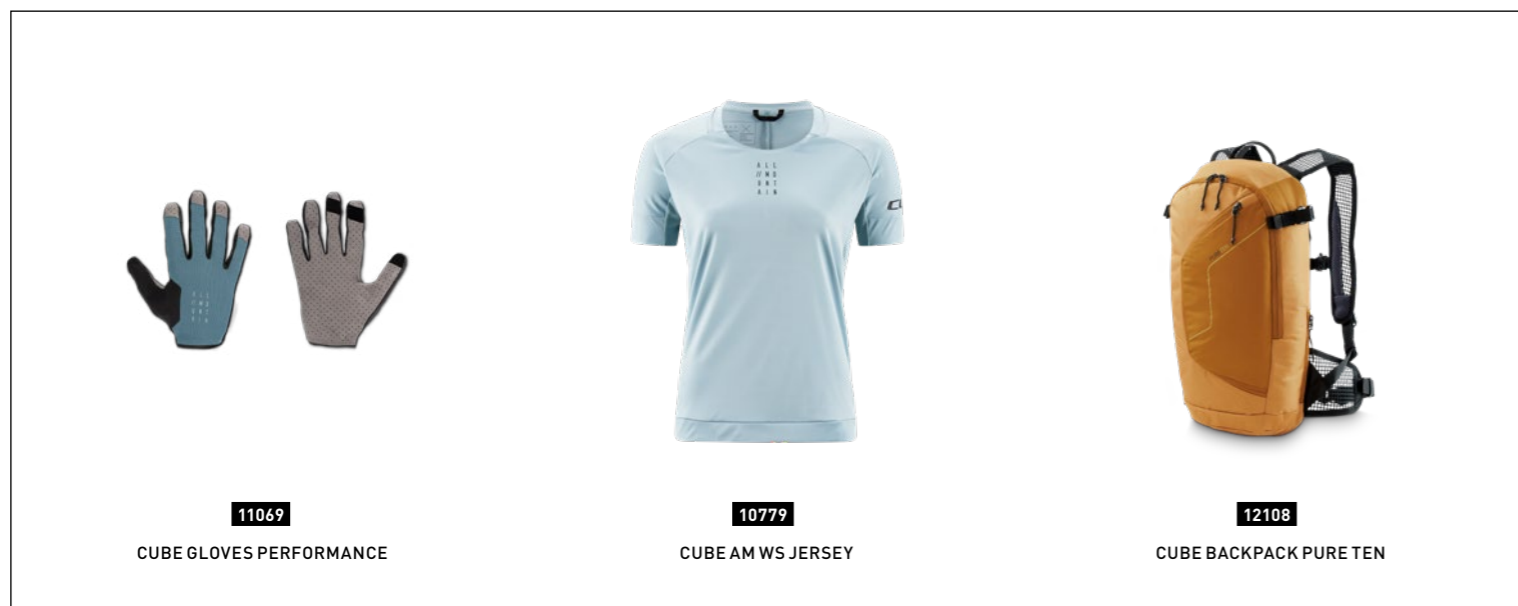

11069

CUBE GLOVES PERFORMANCE



10779

CUBE AM WS JERSEY



12108

CUBE BACKPACK PURE TEN

ACCESS WS EAZ

325200 black 'n' blue



ACCESS WS EAZ

325210 white 'n' berry



You know that saying, „power is nothing without control“? We took it to heart with the Access WS EAZ. That’s why it’s equipped with powerful, easy-to-control Tektro hydraulic disc brakes and grippy, easy-rolling Schwalbe Smart Sam tyres – so that you can be assured of safe, all-weather braking at all times. It’s just the kind of attention to detail that we put into every one of our bikes. You might not initially notice features like the internal cable routing, but you’ll be glad of it because it helps keep your gears shifting smoothly with absolutely minimal maintenance. We also lowered the top tube slightly for extra clearance, and fitted hidden rack and fender mounts for added versatility. Like all our WS bikes, our designers selected women-specific rider contact points for the best day-long comfort, whilst Size Split means every rider can find her perfect fit. Throw in the Suntour suspension fork and reliable Shimano gears, and it all adds up to a recipe for enjoying every ride.

FRAME Aluminium Lite, AMF, Internal Cable Routing, Easy Mount Kickstand Ready
SIZE Size Split: 27.5: 13.5", 16" // 29: 17", 19"
FORK Suntour XCT Disc, 100mm, Remote Lockout

HEADSET CUBE FPH863, Semi-Integrated
STEM CUBE Performance Stem, 31.8mm
HANDLEBAR CUBE Rise Trail Bar, 680mm
GRIPS CUBE Performance Grip
REAR DERAILLEUR Shimano RD-M360, 8-Speed
SHIFTERS Shimano SL-M315, Rapidfire-Plus
FRONT DERAILLEUR Shimano FD-TY700-TS6, Dual Pull, 31.8mm Clamp
BRAKE SYSTEM Tektro HD-M275, Hydr. Disc Brake (160/160)
CRANKSET Shimano FC-TY501, 42x34x24T, 170mm
CASSETTE Shimano CS-HG200, 12-32T
CHAIN MC CUB.3
RIMS CUBE SD20, 32H, Disc
FRONT HUB CUBE Disc Hub, 6-Bolt
REAR HUB CUBE Disc Hub, 6-Bolt
TYRES Schwalbe Smart Sam, Active, 2.1
PEDALS CUBE HPP MTB
SADDLE Natural Fit Venec Lite WS
SEAT POST CUBE Performance Post, 27.2mm
SEATCLAMP CUBE Varioclose, 31.8mm

WEIGHT #3,8 kg



14162
CUBE PEDALS ALL MOUNTAIN

13851
RFR POWER LIGHT 300 USB „WHITE“

11291
CUBE TOUR WS JERSEY

SPARE PARTS#
10148 CUBE Hanger #148 short version
10324 CUBE Headset Orbit Z
13456 RFR Seatclamp with Quick Release 31,8 mm
13543 Inner Tube 27,5"/29" MTB AGV 40 mm



One bike to do it all: is that even possible? If you have to ask the question, you've clearly not met the Access WS Allroad – a bike that's both a Jack of all trades and a master of them, too. Starting with all the benefits of our rugged, reliable and comfortable Access, we added mudguards, a built-in kickstand and a set of lights. The result is a true off-roader that'll slot right into your busy life by tackling the trip across town, too. And, of course, none of the Allroad's added can-do attitude detracts from the Access's go-anywhere credentials. It's got the same carefully tailored geometry, women-specific rider contact points and reliable, easy-to-use components as its little sister. With powerful all-weather mechanical disc brakes and the added comfort and control of a Suntour suspension fork, you've got the perfect package for exploring off-road... or wherever your curiosity leads you.

FRAME Aluminium Lite, AMF, Internal Cable Routing, Easy Mount Kickstand Ready
SIZE Size Split: 27.5: 13.5", 16" // 29: 17", 19"
FORK R Suntour XCE, 100mm

HEADSET CUBE FPH863, Semi-Integrated
STEM CUBE Performance Stem, 31.8mm
HANDLEBAR CUBE Rise Trail Bar, 680mm
GRIPS CUBE Performance Grip
REAR DERAILLEUR Shimano RD-TX800, 8-Speed
SHIFTERS Shimano ST-TX800, EZ Fire Plus
FRONT DERAILLEUR Shimano FD-TY700-TS6, Dual Pull, 31.8mm Clamp
BRAKE SYSTEM Ektro MD-280, Mech. Disc Brake
CRANKSET Shimano FC-TY501, 42x34x24T, 170mm
CASSETTE Shimano CS-HG200, 12-32T
CHAIN MC CU8.3
RIMS CUBE SD20, 32H, Disc
FRONT HUB Shimano DH-3D32 Hub Dynamo
REAR HUB CUBE Aluminium
TYRES Schwalbe Smart Sam, Active, 2.1
PEDALS CUBE HPP MTB
SADDLE Natural Fit Venec Lite WS
SEAT POST CUBE Performance Post, 27.2mm
SEATCLAMP CUBE Varioclose, 31.8mm
FRONT LIGHT Büchel Country LED
REAR LIGHT relock Standlight
KICKSTAND CUBE Stand Cmpt
MUDGUARDS ACID 60
BELL luvo

WEIGHT #5,6 kg

SPARE PARTS#
10148 CUBE Hanger #148 short version
10324 CUBE Headset Orbit Z
13456 RFR Seatclamp with Quick Release 31,8 mm
13543 Inner Tube 27,5"/29" MTB AGV 40 mm



11290
CUBE TOUR WS BAGGY SHORTS

11100
CUBE TOUR CORE WS JERSEY

93040
ACID REAR CARRIER SIC 29" RILINK

ACCESS WS

325100 black 'n' mint



ACCESS WS

325110 blue 'n' green



When you've got the urge to explore off-road, you'll want a bike that's up to the job: comfortable, reliable and easy to handle. That's why we developed the Access. Like all of our women-specific bikes, it's a complete tailored package with the emphasis on all-day comfort, responsive but stable handling, and safety you can depend on. We paid particular attention to the geometry, saddle, stem length and handlebar width – so that every ride is a pleasure, not a chore. Mechanical disc brakes give you the power you need to stop safely in any conditions, while 24 slick-shifting Shimano gears mean you're just a click away from tackling any trail or hill. There's even a Suntour suspension fork to take the sting out of the trail and the edge of potholes and bumps. And, with our Size Split setup, there's an Access to suit every woman. It's a bike that has everything you need and nothing that you don't – just get out and enjoy the ride!

FRAME Aluminium Lite, AMF, Internal Cable Routing, Easy Mount Kickstand Ready
SIZE Size Split: 27.5: 13.5", 16" // 29: 17", 19"
FORK SR Suntour XCE, 100mm

HEADSET CUBE FPH863, Semi-Integrated
STEM CUBE Performance Stem, 31.8mm
HANDLEBAR CUBE Rise Trail Bar, 680mm
GRIPS CUBE Performance Grip
REAR DERAILLEUR Shimano RD-TX800, 8-Speed
SHIFTERS Shimano ST-TX800, EZ Fire Plus
FRONT DERAILLEUR Shimano FD-TY700-TS6, Dual Pull, 31.8mm Clamp
BRAKE SYSTEM Ektro MD-280, Mech. Disc Brake
CRANKSET Shimano FC-T501, 42x34x24T, 170mm
CASSETTE Shimano CS-HG200, 12-32T
CHAIN MC CU8.3
RIMS CUBE SD20, 32H, Disc
FRONT HUB CUBE Aluminium
REAR HUB CUBE Aluminium
TYRES Schwalbe Smart Sam, Active, 2.1
PEDALS CUBE HPP MTB
SADDLE Natural Fit Venec Lite WS
SEAT POST CUBE Performance Post, 27.2mm
SEATCLAMP CUBE Varioclose, 31.8mm

WEIGHT 3,9 kg

SPARE PARTS#
10148 CUBE Hanger #148 short version
10324 CUBE Headset Orbit Z
13543 Inner Tube 27,5"/29" MTB AGV 40 mm

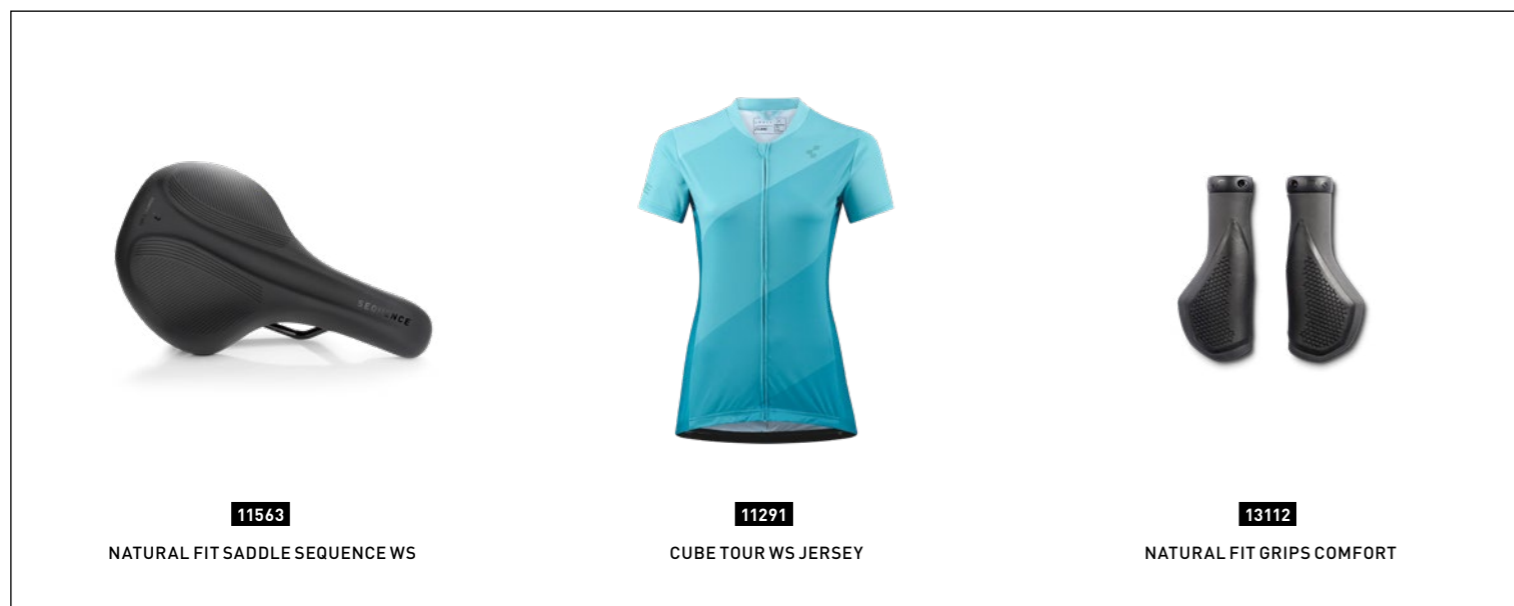

11563
NATURAL FIT SADDLE SEQUENCE WS

11291
CUBE TOUR WS JERSEY

13112
NATURAL FIT GRIPS COMFORT

FOR us #womenontrails

All our carbon frame-building expertise is poured into the Sting 140 HPC's elegant, light and incredibly stiff front triangle. Internal cable routing keeps your gear shifts clean and your time clear for riding, not fiddling with maintenance tasks. The tapered head tube and refined geometry are designed to cater specifically for the demands of a 150mm fork – so you'll always be in full control, no matter how tough the trail. At the rear, we've applied all our aluminium know-how into a stiff, strong and lightweight structure that works seamlessly with the rest of the frame. Short chain stays serve up superb climbing performance, and the steep seat angle and long reach are part of the package that we designed specifically to deliver sharp, safe and confidence-inspiring handling. Ride more, whatever that means for you.



STING WS 140 HPC SL

328400 team ws



If you appreciate the finer things in life – like shredding prime singletrack – then you’re sure to like this. The Sting WS 140 HPC SL is an uncompromisingly light, stiff, fast and agile suspension bike built with one goal in mind: to be the best of its kind. To that end, there’s some clever stuff going on in its carbon and aluminium frame. Short chain stays, a steep seat angle, lots of reach and a head angle designed for 150mm forks are just some of the ingredients we’ve thrown into this trail-taming recipe. The result is a bike that climbs as well as it descends – which is to say, brilliantly. And with that kind of performance, it’ll come as no surprise that our designers went to town in kitting this bike out. From the Fox Float Factory 34 fork and matching Fox Float DPX2 rear shock to the Newmen wheelset and Sram X01 1x12 transmission with Sram G2 RSC hydraulic disc brakes, we’ve selected only the best of the best so that you can ride at your best, too. We even included a Fox Transfer Factory dropper post to help with tackling those especially tricky steep, technical lines. And, with frame sizes starting at 13.5 inch, there’s bound to be a Sting WS 140 HPC SL with your name on it. Like all the best things in life, it won’t let you down.

- FRAME#**HPC Carbon Monocoque Advanced Twin Mold Technology, Aluminum 6061 T6 Rear Triangle, ATG, ETC 4-Link, ISCG Mount, Boost 148, AXH
- SIZE#**3,5", 16", 18", 20"
- FORK#**ox 34 Float Factory, Tapered, 15x110mm, 150mm, 3-Position Micro-Adjust GRIP Damper
- SHOCK#**ox Float DPX2 Factory EVOL, 185x52.5mm Trunnion Mount, Open(Adjustable)/Medium/Firm
- SHOCK HARDWARE#**op: 54mm Trunnion Mount, Bottom: 22x8mm

- HEADSET#**SA Orbit I-t, Integrated, Top 1 1/8", Bottom 1 1/2"
- STEM#**Newmen Evolution SL 318.4, 31.8mm
- HANDLEBAR#**Newmen Evolution 318.20, 760mm
- GRIPS#**CUBE Race SL Grip 29.5mm, 1-Clamp
- REAR DERAILLEUR#**Sram X01 Eagle™, 12-Speed
- SHIFTERS#**Sram GX Eagle™ Trigger
- BRAKE SYSTEM#**Sram G2 RSC, Hydr. Disc Brake (200/180)
- CRANKSET#**Sram X1 Eagle™ Carbon, 32T, 170mm
- CASSETTE#**Sram XG-1275, 10-50T
- CHAIN#**Sram GX Eagle™
- WHEELSET#**Newmen Evolution SL A.25, 28/28 Spokes, 15x110mm / 12x148mm, Tubeless Ready
- FRONT TIRE#**Schwalbe Magic Mary, Addix Soft, Kevlar, Tubeless Easy, 2.35
- REAR TIRE#**Schwalbe Hans Dampf, Addix Speedgrip, Kevlar, Tubeless Easy, 2.35
- SADDLE#**Natural Fit Venec WS
- SEAT POST#**ox Transfer Factory 31.6mm, Kashima coated, 13.5" 356x100mm, 16" 406x125mm, 18" & 20" 456x150mm
- SEATCLAMP#**CUBE Screwlock, 34.9mm

WEIGHT#2,4 kg

- SPARE PARTS#**
- 8651** CUBE HANGER_mtb-x12-std-2020 (18-05516)
- 13545** Inner Tube 27,5"/29" MTB SV 40 mm

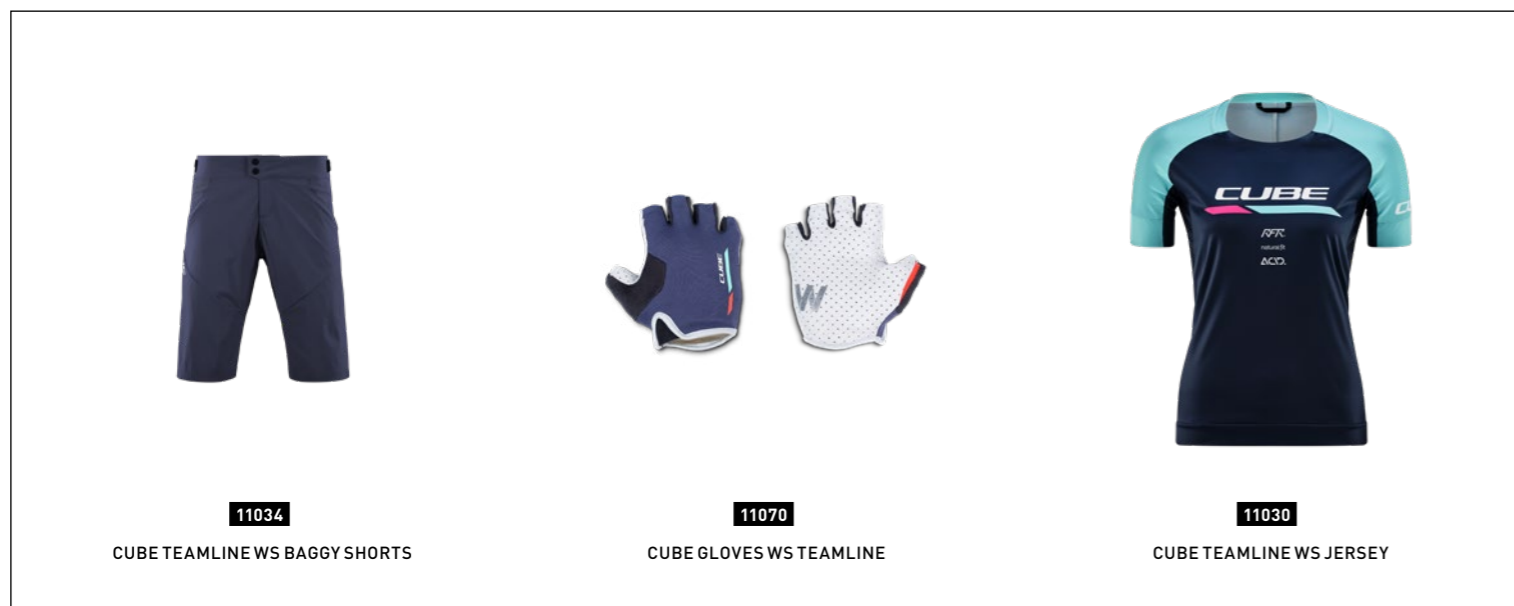

11034
CUBE TEAMLINE WS BAGGY SHORTS

11070
CUBE GLOVES WS TEAMLINE

11030
CUBE TEAMLINE WS JERSEY

STING WS 140 HPC RACE

328300 carbon'n'rubinred

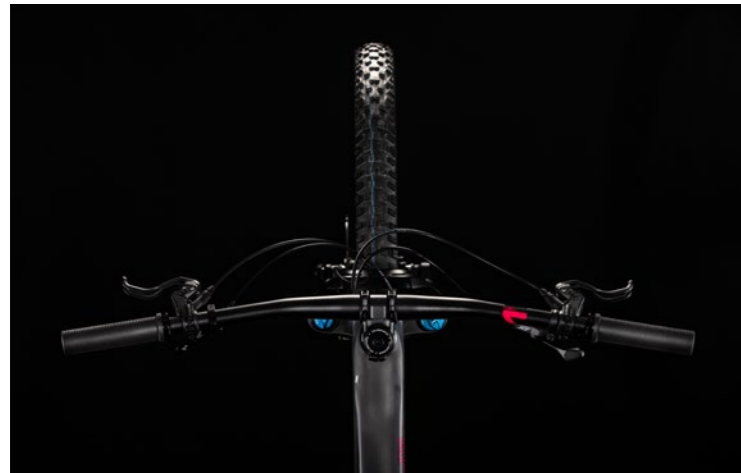

Big days out in big country demand a bike that's up to the task. Borrowing technology we developed partly out of experience born from racing mountain bikes on some of the planet's most challenging trails, the Sting WS 140 HPC Race doesn't hold back in helping you get the best out of your trail riding. The carbon main frame is available in sizes right down to 13.5 inch, which means every rider should be able to find her perfect fit. The tapered head tube and refined geometry are designed to cater specifically for a 150mm fork and, like all our frames, it's flown through the torture-testing processes of our own in-house, 24/7 test lab. The easily adjustable Fox 34 Rhythm fork and Fox Float DPS EVOL shock work in tandem to smooth your way down even the gnarliest trail, while grippy Schwalbe tyres and powerful Magura MT Trail hydraulic disc brakes give you the bite and control you need to keep your speed in check. We selected a light, strong and stiff Fulcrum wheelset, and Shimano's superb and wide-ranging 1x12 transmission puts an absolutely enormous range of gears right by your right thumb. Yes, it really is that easy. Put it all together and the Sting WS 140 HPC Race is every woman's ticket to longer, more adventurous rides – whether you're tackling steep switchbacks or a fast, rolling singletrack descent. Sounds fun, right?

FRAME#HPC Carbon Monocoque Advanced Twin Mold Technology, Aluminum 6061 T6 Rear Triangle, ATG, ETC 4-Link, ISCG Mount, Boost 148, AXH
SIZE#3.5", 16", 18", 20"
FORK#Fox 34 Rhythm, Tapered, 15x110mm, 150mm, 2-Position Sweep-Adjust Grip Damper
SHOCK#Fox Float DPS EVOL, 185x52.5mm Trunnion Mount, Open/Medium/Firm Mode
SHOCK HARDWARE#Top: 54mm Trunnion Mount, Bottom: 22x8mm

HEADSET#SA Orbit I-t, Integrated, Top 1 1/8", Bottom 1 1/2"
STEM#Newmen Evolution SL 318.4, 31.8mm
HANDLEBAR#Newmen Evolution 318.20, 760mm
GRIPS#CUBE Race SL Grip 29.5mm, 1-Clamp
REAR DERAILLEUR#Shimano XT RD-M8100-SGS, ShadowPlus, 12-Speed
SHIFTERS#Shimano XT SL-M8100
BRAKE SYSTEM#Magura MT Trail Custom [180/180]
CRANKSET#Shimano XT FC-M8100, 32T, Boost, 170mm
CASSETTE#Shimano SLX CS-M7100, 10-51T
CHAIN#Shimano CN-M7100
WHEELSET#Fulcrum Red Zone 700 Boost, 28/28 Spokes, 15x110mm/12x148mm, Tubeless-Ready
TYRES#Schwalbe Nobby Nic, Addix Speedgrip, Kevlar, Tubeless Easy, 2.35
SADDLE#Natural Fit Venec WS
SEAT POST#CUBE Dropper Post, Handlebar Lever, Internal Cable Routing, 31.6mm, 13.5" 370x100mm, 16" 420x125mm, 18" & 20" 480x150mm
SEATCLAMP#CUBE Screwlock, 34.9mm

WEIGHT#2.7 kg

SPARE PARTS
8651 CUBE HANGER_mtb-x12-std-2020 [18-05516]
11270 CUBE Grips Race SL
13545 Inner Tube 27.5"/29" MTB SV 40 mm

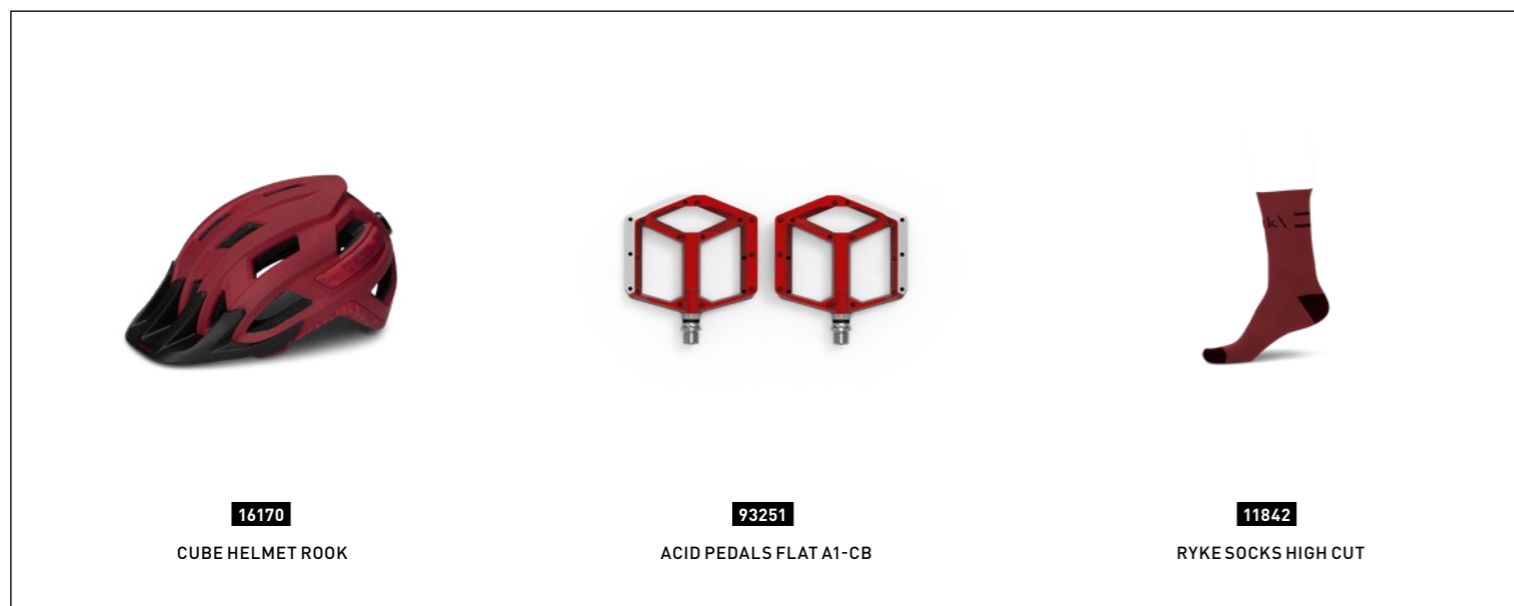

16170

CUBE HELMET ROK

93251

ACID PEDALS FLAT A1-CB

11842

RYKE SOCKS HIGH CUT





STING WS 120 PRO

327200 titan 'n' mint



We developed the Sting WS 120 Pro for women who ride that little bit further, that little bit faster... and that little bit more adventurously. With a redesigned frame for 2020, we've taken its reputation for comfort and control and added a dose more trail sass with revised geometry, so you can push yourself as far as you like. The frame's swoopy lines and clean looks disguise our engineers' clever use of complex hydroforming and triple-butted tubing to reduce weight without sacrificing strength and safety, while hidden shock pivots and internally routed cables also reduce maintenance down-time. The eas- to-adjust RockShox Sektor air suspension fork works in tandem with the RockShox Deluxe Select+ rear shock to keep your Schwalbe-shod wheels hugging the trail, while Shimano's exceptionally wide-ranging 1x12 transmission puts the right gear for any situation a click or two away. Oh, and powerful hydraulic disc brakes and a dropper seat post ensure you'll always be in full control, no matter what the trail throws at you. And Size Split means that every rider can find her perfect fit, from the 13.5-inch frame with 27.5in wheels to the 20-inch frame with 29er wheels. There's literally a Sting WS 120 Pro to suit every rider...

-  **FRAME#**HPA Ultralight, Advanced Hydroforming, Triple Butted, ETC 4-Link, AXH
- SIZE#**Size Split: 27.5: 13.5" // 29: 16", 18", 20"
- FORK#**RockShox Sektor RL Air, Tapered, 130mm
- SHOCK#**RockShox Deluxe Select+ 190x45mm
- SHOCK HARDWARE#**op: 40x8mm, Bottom: 22x8mm

-  **HEADSET#**SA 1.5E ZS, Tapered, Top Zero-Stack 1 1/8" (OD 44mm), Bottom Zero-Stack 1 1/2" (OD 56mm)
- STEM#**Newmen Evolution 318.4, 31.8mm
- HANDLEBAR#**Newmen Evolution 318.20, 760mm
- GRIPS#**CUBE Race SL Grip 29.5mm, 1-Clamp
- REAR DERAILLEUR#**Shimano XT RD-M8100-SGS, ShadowPlus, 12-Speed
- SHIFTERS#**Shimano SLX SL-M7100
- BRAKE SYSTEM#**Shimano BR-MT500, Hydr. Disc Brake (180/180)
- CRANKSET#**Shimano FC-MT610, Boost, 30T, 175mm (Smaller Sizes 170mm)
- CASSETTE#**Shimano SLX CS-M7100, 10-51T
- CHAIN#**Shimano CN-M7100
- WHEELSET#**Fulcrum Red Zone 500 Boost, 15x110mm / 12x142mm, Tubeless-Ready
- TYRES#**Schwalbe Nobby Nic, Addix Performance, Kevlar, 2.35
- SADDLE#**Natural Fit Venec WS
- SEAT POST#**CUBE Dropper Post, Handlebar Lever, Internal Cable Routing, 30.9mm (16": 361x100mm; 18": 403x120mm; 20": 425x130mm)
- SEATCLAMP#**CUBE Screwlock, 34.9mm

 **WEIGHT#**3.8 kg

-  **SPARE PARTS#**
- 8651** CUBE HANGER_mtb-x12-std-2020 (18-05516)
- 10546** CUBE Rock Mount Set Stereo/Sting 120 HPA 27/29 MY 2016
- 13545** Inner Tube 27,5"/29" MTB SV 40 mm



12103
CUBE BACKPACK EDGE TWENTY

10700
CUBE AM WS BAGGY SHORTS

10778
CUBE AM WS JERSEY

STING WS 120 EXC

327100 turquoise 'n' black



At CUBE we never, ever rest on our laurels. That's why, for 2020, we completely redesigned the Sting WS EXC's frame. Featuring triple butting and complex hydroforming to shave weight wherever possible and ensure strength where it's needed, it's more than just mountain bike eye candy. The sleek looks disguise practical features like hidden suspension pivots and internal cable routing, for reduced maintenance. Revised geometry makes it more trail-capable and intuitive to handle than ever before, so you can concentrate on enjoying the ride. And the components are designed to be durable, reliable and easy to use. So there's an easily adjustable Suntour suspension fork and matching rear shock, to smooth out the trail ahead of you. We selected Sram's legendary 1x12 Eagle transmission for its incredible gear range and ease of use. And powerful Shimano hydraulic disc brakes with grippy Schwalbe tyres ensure you're always in full control, no matter how wet and muddy the trail gets. From a short trail centre spin to a long day out in the mountains, you'll be surprised how much 120mm of rear suspension can open up new horizons. And, with our clever Size Split system, every rider can find her perfect fit. What's stopping you?

FRAME#HPA Ultralight, Advanced Hydroforming, Triple Butted, ETC 4-Link, AXH
SIZE#Size Split: 27.5: 13.5" // 29: 16", 18", 20"
FORK#R Suntour XCR34 Air Boost, 130mm
SHOCK#Suntour Edge R 190x45mm
SHOCK HARDWARE#Top: 40x8mm, Bottom: 22x8mm

HEADSET#CUBE H868P, Semi-Integrated
STEM#CUBE Performance Stem Pro, 31.8mm
HANDLEBAR#CUBE Rise Trail Bar, 720mm
GRIPS#CUBE Performance Grip
REAR DERAILLEUR#Sram SX Eagle™, 12-Speed
SHIFTERS#Sram SX Eagle™ Trigger
BRAKE SYSTEM#Shimano BR-MT400, Hydr. Disc Brake (180/180)
CRANKSET#Sram X1 1000 Eagle™ DUB 30T, Boost, 175mm (Smaller Sizes 170mm)
CASSETTE#Sram PG-1210 Eagle™, 11-50T
CHAIN#Sram SX Eagle™
RIMS#CUBE MD23, 32H, Disc, Tubeless Ready
FRONT HUB#Shimano HB-MT400-B, 15mm, Boost, Centerlock
REAR HUB#Shimano FH-MT400-B, 12mm, Boost, Centerlock
TYRES#Schwalbe Nobby Nic, Addix Performance, Kevlar, 2.25
SADDLE#Natural Fit Venec Lite WS
SEAT POST#CUBE Dropper Post, Handlebar Lever, Internal Cable Routing, 30.9mm (16": 361x100mm; 18": 403x120mm; 20": 425x130mm)
SEATCLAMP#CUBE Screwlock, 34.9mm

WEIGHT#4,5 kg

SPARE PARTS#
8651 CUBE HANGER_mtb-x12-std-2020 (18-05516)
10546 CUBE Rock Mount Set Stereo/Sting 120 HPA 27/29 MY 2016
13545 Inner Tube 27,5"/29" MTB SV 40 mm



11286
CUBE TOUR WS BAGGY SHORTS
INCL. LINER SHORTS



12111
CUBE BACKPACK OX 25+



11291
CUBE TOUR WS JERSEY

FOR us #Roadies

This is pure, high-end carbon frame construction. Our Advanced Twin Mold monocoque technology gives us full control over fibre lay-up during construction, so we can fine-tune every area of the frame to optimise both weight and stiffness. The icing on the cake is our premium C:62 carbon, which has the strength to enable us to build such a lightweight yet exceptionally fast chassis. Oversized main tubes and chain stays – combined with a tapered head tube, extremely stiff bottom bracket and 12mm thru axles front and rear – are instrumental in achieving a stiffness-to-weight ratio that's the envy of our competitors. Controlled flex in the seat stays, a flattened top tube and the carbon fork blades all add comfort without compromising efficiency, so you'll be able to ride at your full potential on even the longest of races or training days. And, of course, internal cable routing minimises maintenance, maximises gear change precision... and complements the frame's stunning looks.





The Axial WS C:62 SL Team's combination of the best frame materials and the finest components makes it the perfect choice for the discerning racer in you, whether you're battling for position in the peloton or duking it out with your training buddies on a Tuesday night. You don't need to compromise because we didn't, either. Our Advanced Twin Mold monocoque technology gives us full control over fibre lay-up during construction, so we can fine tune every area of the frame to optimise weight and stiffness. The icing on the cake is our premium C:62 carbon, which has the strength to enable us to build such a lightweight yet exceptionally strong chassis. Controlled flex in the seat stays, a flattened top tube and carbon fork blades all add comfort without compromising efficiency. And we didn't stop there. Shimano's peerless 2x11 Ultegra transmission serves up flawless gear shifts every time, while matching hydraulic disc brakes offer perfect modulation and control in any weather conditions. Throw in the light, stiff and strong Newmen wheelset and grippy, fast-rolling Continental tyres, and you've got all the ingredients for a supremely fast, agile and light race machine.

FRAME# C:62 Advanced Twin Mold Technology Aero Frame, Flat Mount Disc, Road Aero Endurance Geometry, AXH, 12x142mm
SIZE# 7, 50, 53, 56
FORK# CUBE CSL Evo Aero C:62 Technology, 1 1/8" / 1 1/4" Tapered, Flat Mount, 12x100mm

HEADSET# SA I-t; Top Integrated 1 1/8", Bottom Integrated 1 1/4"
STEM# Newmen Evolution 318.4, 31.8mm
HANDLEBAR# Newmen Advanced Wing Bar, Carbon
HANDLEBAR TAPE# CUBE Grip Control
REAR DERAILLEUR# Shimano Ultegra RD-R8000-DGS, 11-Speed
FRONT DERAILLEUR# Shimano Ultegra FD-R8000-F
SHIFT/ BRAKE LEVERS# Shimano Ultegra ST-R8025
BRAKE SYSTEM# Shimano Ultegra BR-R8070, Hydr. Disc Brake, Flat Mount (160/160)
CRANKSET# Shimano Ultegra FC-R8000, Hollowtech II, 50x34T, 170mm (56cm: 172,5mm)
CASSETTE# Shimano Ultegra CS-R8000, 11-32T
CHAIN# Shimano CN-HG701
WHEELSET# Newmen Evolution SL R.32, 24/24 Spokes, 12x100mm/12x142mm, Tubeless Ready
TYRES# Conti Grand Sport Race SL, 28-622
SADDLE# Natural Fit Venec WS
SEAT POST# Newmen Advanced, Carbon, 27.2mm
SEATCLAMP# CUBE Screwlock, 31.8mm

WEIGHT# 3 kg

SPARE PARTS#
10063 CUBE Hanger Attain/Agree/Cross Race/Gravel
10360 CUBE Headset FSA I-t, Top Integrated 1 1/8", Bottom Integrated 1 1/4"
13553 Inner Tube 28" ROAD SV 60 mm extra light
33041 CUBE Bar Tape Carbon

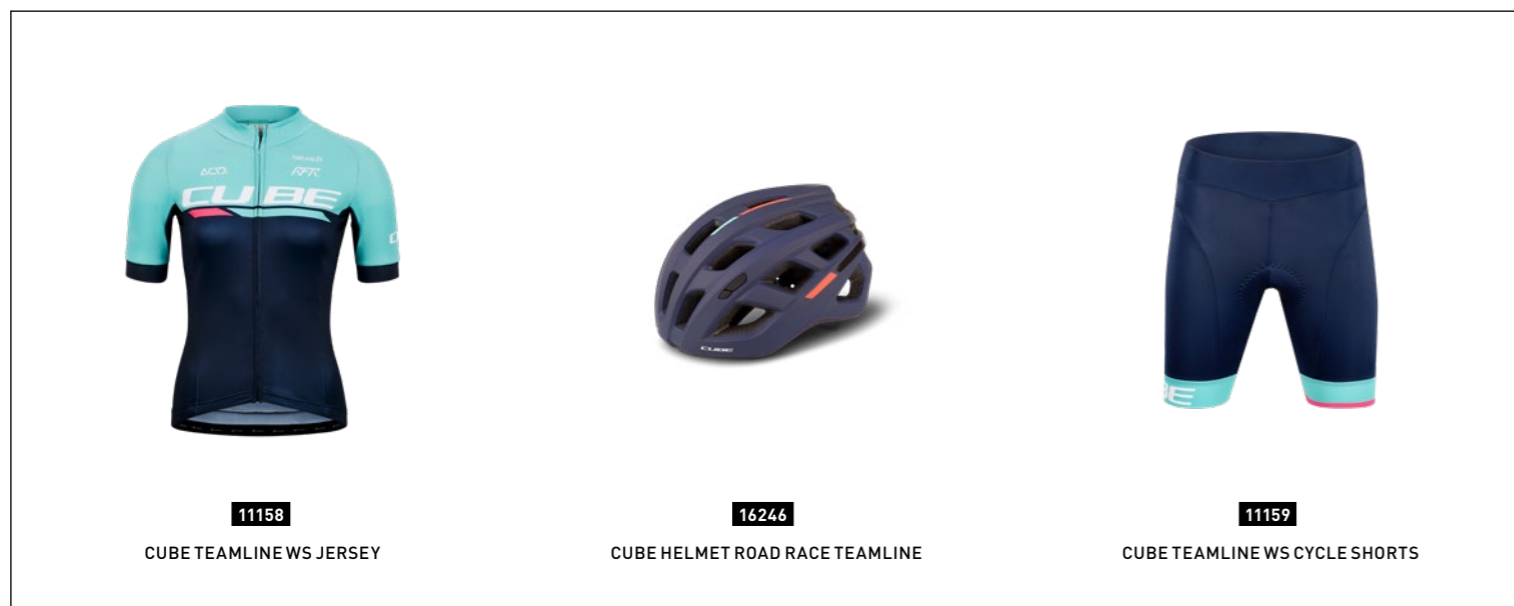

11158
CUBE TEAMLINE WS JERSEY

16246
CUBE HELMET ROAD RACE TEAMLINE

11159
CUBE TEAMLINE WS CYCLE SHORTS

AXIAL WS GTC SL

329500 carbon 'n' hazypurple



Want to keep chipping away at your personal best? Then you'll like our Axial WS GTC SL – the ideal bike any rider who appreciates how great equipment can help bring out her best performance. Its carbon frame, precision manufactured using our Twin Mold technology and tested to destruction in our 24/7 test lab to confirm its strength and durability, has an ideal stiffness-to-weight ratio. From the oversized main frame tubes to the 12mm rear axle and reinforced head tube area, the frame's rigid backbone transfers all your efforts to the light, stiff and strong Fulcrum wheelset. Meanwhile the carbon fork and slender seat stays help filter out tiring vibrations, so you can continue to ride at your best late into the day. Smooth, wide-ranging Shimano Ultegra gears put the perfect ratio for any road at your fingertips, while powerful Shimano 105 hydraulic disc brakes offer confidence-enhancing all-weather performance. Light, fast and comfortable: The Axial WS GTC SL is all three of these things, perfected.

FRAME #GTC Monocoque Twin Mold Technology, Flat Mount Disc, Road Comfort Geometry, AXH, 12x142mm
SIZE #7, 50, 53, 56
FORK #CUBE CSL Race Disc, Full Carbon, Flat Mount, 1 1/8" - 1 1/4" Tapered, 12x100mm

HEADSET #SA I-t, Top Integrated 1 1/8", Bottom Integrated 1 1/4"
STEM #Newmen Evolution 318.4, 31.8mm
HANDLEBAR #Newmen Evolution Wing Bar
HANDLEBAR TAPE #CUBE Grip Control
REAR DERAILLEUR #Shimano Ultegra RD-R8000-DGS, 11-Speed
FRONT DERAILLEUR #Shimano Ultegra FD-R8000-BM, 31.8mm Clamp
SHIFT/ BRAKE LEVERS #Shimano 105 ST-R7025
BRAKE SYSTEM #Shimano 105 BR-R7070, Hydr. Disc Brake, Flat Mount [160/160]
CRANKSET #Shimano Ultegra FC-R8000, Hollowtech II, 50x34T, 170mm [56cm: 172,5mm]
CASSETTE #Shimano CS-R7000, 11-32T
CHAIN #Shimano CN-HG601
WHEELSET #Fulcrum Racing 77 DB, 12x100mm/12x142mm, Tubeless Ready
TYRES #Conti Grand Sport Race SL, 28-622
SADDLE #Natural Fit Venec WS
SEAT POST #Newmen Evolution, 27.2mm
SEATCLAMP #CUBE Screwlock, 31.8mm

WEIGHT #6,6 kg



16121
CUBE HELMET ROAD RACE

11959
CUBE WS GLOVES X NF

17098
CUBE SHOES RD SYDRIX PRO

SPARE PARTS
10241 CUBE Hanger 2091 AXH [Direct Mount]
10360 CUBE Headset FSA I-t, Top Integrated 1 1/8", Bottom Integrated 1 1/4"
13553 Inner Tube 28" ROAD SV 60 mm extra light

AXIAL WS GTC PRO

329400 lightblue'n'red

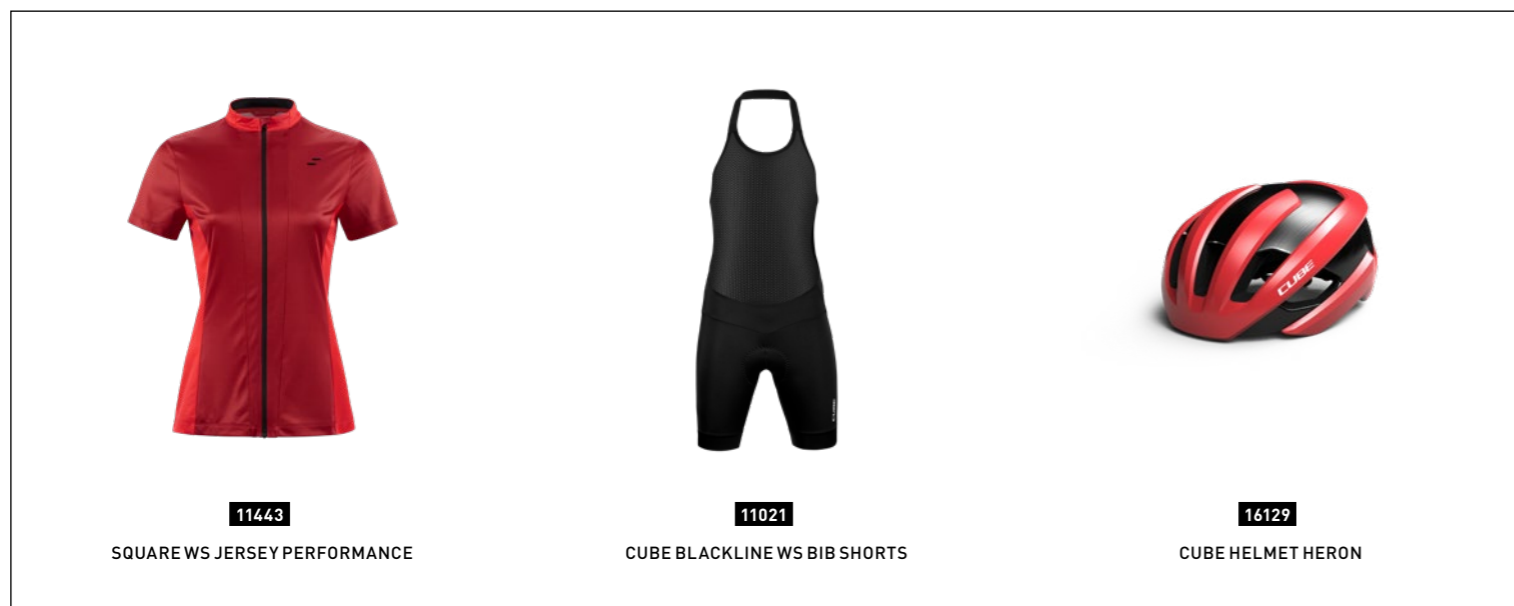

Ready for the big time? The Axial WS GTC Pro takes things up a notch or two. A thoroughbred race machine with performance threaded right through its DNA, it's built around our lightweight Twin Mold carbon fibre frame. The oversized main frame tubes maximise frame rigidity for superb steering precision – good for confidence, and great for speed. Slim seat stays work with the carbon fork to help filter out vibration from the road surface, helping you to stay comfortable even as the miles rack up. And, with a light, stiff and strong CUBE wheelset shod with grippy Continental tyres and Shimano's legendary 105 2x11 groupset, it's fully equipped to perform. Powerful Shimano 105 brakes deliver perfect modulation and low weight for that competitive edge, because better brakes really can help you go faster. All that's missing is the open road.... and you.

FRAME #CUBE Monocoque Twin Mold Technology, Flat Mount Disc, Road Comfort Geometry, AXH, 12x142mm
SIZE #7, 50, 53, 56
FORK #CUBE CSL Race Disc, Full Carbon, Flat Mount, 1 1/8" - 1 1/4" Tapered, 12x100mm

HEADSET #SA I-t, Top Integrated 1 1/8", Bottom Integrated 1 1/4"
STEM #CUBE Performance Stem Pro, 31.8mm
HANDLEBAR #CUBE Compact Race Bar
HANDLEBAR TAPE #CUBE Grip Control
REAR DERAILLEUR #Shimano 105 RD-R7000-DGS, 11-Speed
FRONT DERAILLEUR #Shimano 105 FD-R7000, 31.8mm Clamp
SHIFT/ BRAKE LEVERS #Shimano 105 ST-R7025
BRAKE SYSTEM #Shimano 105 BR-R7070, Hydr. Disc Brake, Flat Mount (160/160)
CRANKSET #Shimano FC-R5510, 50x34T, 170mm (56cm: 172,5mm)
CASSETTE #Shimano CS-R7000, 11-32T
CHAIN #Shimano CN-HG601
WHEELSET #CUBE RA 0.8 Aero Disc, 12x100mm / 12x142mm, 6-Bolt
TYRES #Conti Grand Sport Race SL, 28-622
SADDLE #Natural Fit Venec WS
SEAT POST #CUBE Performance Post, 27.2mm
SEATCLAMP #CUBE Screwlock, 31.8mm

WEIGHT #2 kg

SPARE PARTS
10241 CUBE Hanger 2091 AXH (Direct Mount)
10360 CUBE Headset FSA I-t, Top Integrated 1 1/8", Bottom Integrated 1 1/4"
13552 Inner Tube 28" ROAD SV 60 mm
33036 CUBE Bar Tape Cork

AXIAL WS RACE

329300 iridium'n'aqua



Getting the best out of your training, racing and riding is important. That's why we developed the Axial WS Race – a fast, responsive and great-value speed machine that successfully blends comfort, pace and agility. The double-butted aluminium Superlite chassis includes features like an oversized, cross-ovalised down tube and a tapered head tube, so you can be sure it'll go exactly where you point it, and that every ounce of your effort will go into propelling the bike forward. But it also features a vibration-absorbing carbon fork and slender Flex Stays, to help keep you turning the pedals in comfort for mile after mile. The components are top-notch, too. From the slick-shifting Shimano 105 2x11 drivetrain to the powerful, all-weather Shimano 105 hydraulic disc brakes – with STI levers designed specifically for smaller hands – it's all designed to help you get the best possible blend of speed and comfort. It's the complete performance package, put together by our expert team so you can concentrate on your ride.

FRAME# Aluminium 6061 T6 Superlite, Double Butted, Smooth Welded, 3D Dropouts, Road Comfort Geometry
SIZE# 7, 50, 53, 56
FORK# CUBE CSL Race Disc, One Piece 3D-Forged Steerer/Crown, Carbon Blades, 1 1/8" - 1 1/4" Tapered, Flat Mount, 12x100mm

HEADSET# SA Z-t, Top Zero-Stack 1 1/8" (OD 44mm), Bottom Integrated 1 1/4"
STEM# CUBE Performance Stem Pro, 31.8mm
HANDLEBAR# CUBE Compact Race Bar
HANDLEBAR TAPE# CUBE Grip Control
REAR DERAILLEUR# Shimano 105 RD-R7000-DGS, 11-Speed
FRONT DERAILLEUR# Shimano 105 FD-R7000, 31.8mm Clamp
SHIFT/ BRAKE LEVERS# Shimano 105 ST-R7025
BRAKE SYSTEM# Shimano 105 BR-R7070, Hydr. Disc Brake, Flat Mount (160/160)
CRANKSET# Shimano FC-RS510, 50x34T, 170mm (56cm: 172,5mm)
CASSETTE# Shimano 105 CS-HG700, 11-34T
CHAIN# Shimano CN-HG601
WHEELSET# CUBE RA 0.8 Aero Disc, 12x100mm / 12x142mm, 6-Bolt
TYRES# Conti Ultra Sport 2, 28-622
SADDLE# Natural Fit Venec WS
SEAT POST# CUBE Performance Post, 27.2mm
SEATCLAMP# CUBE Screwlock, 31.8mm

WEIGHT# 7 kg

SPARE PARTS#
10063 CUBE Hanger Attain/Agree/Cross Race/Gravel
10359 CUBE Headset FSA Z-t, Top Zero-Stack 1 1/8" (OD 44mm)
13552 Inner Tube 28" ROAD SV 60 mm
33032 CUBE Natural Fit Bar Tape COMFORT

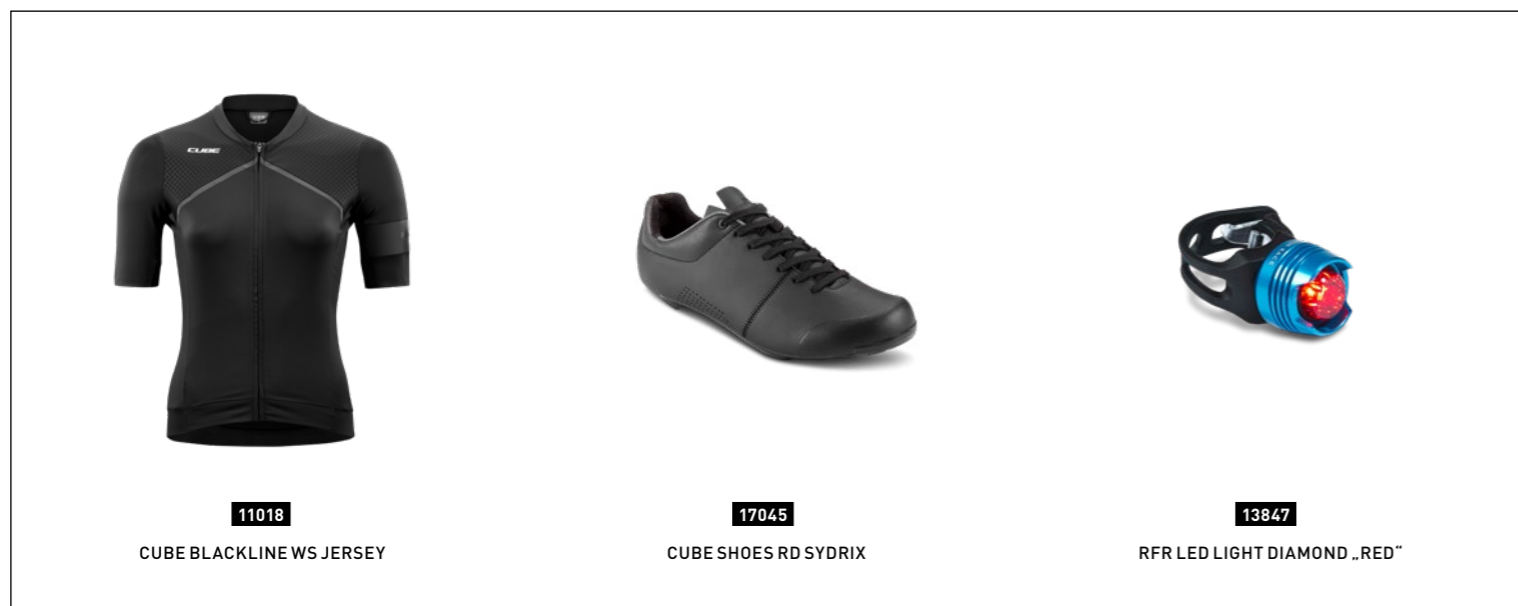

11018
CUBE BLACKLINE WS JERSEY

17045
CUBE SHOES RD SYDRIX

13847
RFR LED LIGHT DIAMOND „RED“

AXIAL WS PRO

329200 greyblue'n'coral



The Axial WS Pro bridges the gap between performance racer and comfortable, long distance tourer. An impossible compromise? We don't think so. Carefully tweaked geometry creates a relaxed, efficient ride position and, combined with a carbon fork and comfort-enhancing Flex Stays, it makes the Axial WS Pro a great companion for the long haul. Internal cable routing reduces the need for maintenance, improves gear-shifting accuracy and perfectly complements the frame's elegant appearance. Our design team chose the precise, reliable Shimano Sora 2x9 transmission for its wide range and crisp, easy gear shifting, and then added Tektro Spyre disc brakes with large 160mm rotors for powerful, consistent and confidence-inspiring braking in any weather conditions. Put it all together and you've got a bike that offers the aspiring racer everything she needs. Ready to experience the best that narrow tyres and performance riding have to offer? The Axial WS Pro is your willing companion.

-  **FRAME#** Aluminium 6061 T6 Superlite, Road Comfort Geometry, Fender Option, 12x142mm
- SIZE#** 7, 50, 53, 56
- FORK#** CUBE CSL Race Disc, One Piece 3D-Forged Steerer/Crown, Carbon Blades, 1 1/8" - 1 1/4" Tapered, Flat Mount, 12x100mm

-  **HEADSET#** SA Z-t, Top Zero-Stack 1 1/8" (OD 44mm), Bottom Integrated 1 1/4"
- STEM#** CUBE Performance Stem Pro, 31.8mm
- HANDLEBAR#** CUBE Compact Race Bar
- HANDLEBAR TAPE#** CUBE Grip Control
- REAR DERAILLEUR#** Shimano Sora RD-R3000, 9-Speed
- FRONT DERAILLEUR#** Shimano Sora FD-R3000-BM, 31.8mm Clamp
- SHIFT/ BRAKE LEVERS#** Shimano Sora ST-R3000
- BRAKE SYSTEM#** RP Spyre MD-C610C, Flat Mount
- CRANKSET#** Shimano Sora FC-R3000, 9-Speed, 50x34T, 170mm
- CASSETTE#** Shimano CS-HG200, 11-34T
- CHAIN#** MC X9
- WHEELSET#** CUBE RA 0.8 Aero Disc, 12x100mm / 12x142mm, 6-Bolt
- TYRES#** Conti Ultra Sport 2, 28-622
- SADDLE#** Natural Fit Venec Lite WS
- SEAT POST#** CUBE Performance Post, 27.2mm
- SEATCLAMP#** CUBE Screwlock, 31.8mm

 **WEIGHT#** 9 kg

-  **SPARE PARTS#**
- 10240** CUBE Hanger 2090 AXH
- 10359** CUBE Headset FSA Z-t, Top Zero-Stack 1 1/8" (OD 44mm)
- 13551** Inner Tube 28" ROAD SV 40 mm

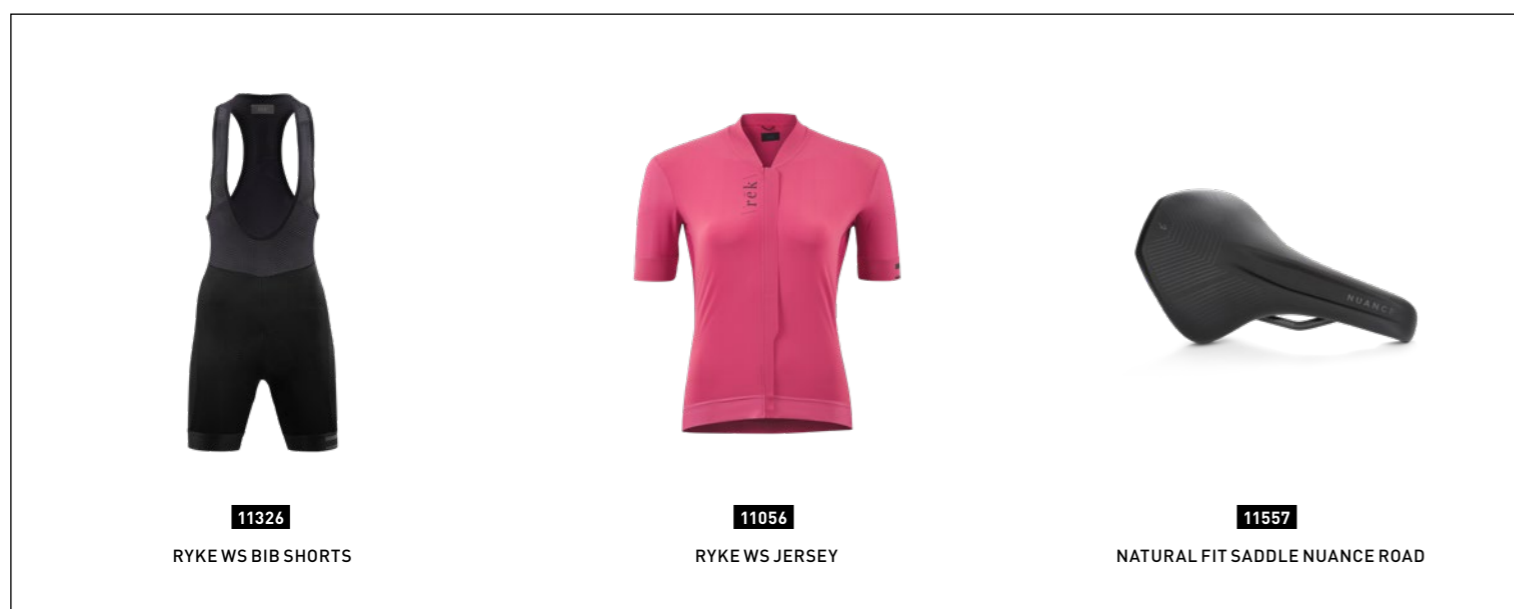

11326
RYKE WS BIB SHORTS

11056
RYKE WS JERSEY

11557
NATURAL FIT SADDLE NUANCE ROAD

AXIAL WS

329100 lightgrey'n'green



Feel the need for speed, at least some of the time? The Axial WS should be right up your street, then. The high-quality, lightweight aluminium frame is designed with comfort and efficiency in mind, complemented by a carbon bladed fork to help filter out road vibration. The cross-ovalised Flex Stays, combined with a slender 27.2mm seat post, are designed to add extra comfort, and the geometry ensures a compact but efficient and comfortable ride position that's particularly well suited to longer distances. Our designers selected Shimano's Claris groupset for its wide gear range and easy shifting, while the PressFit bottom bracket and Hollowtech 2 cranks help reduce weight. With Continental Ultra Sport 2 tyres on a CUBE wheelset with DT Swiss spokes and a saddle, stem and handlebar specially selected for women riders, you'll be fully equipped for any ride, wherever it takes you. A wide range of sizes means every woman can find exactly the right fit, too. Add it all up, and the Axial WS is a versatile sports tourer with your name on it. Where will it take you next weekend?

FRAME# Aluminium 6061 T6 Superlite, Road Comfort Geometry
SIZE# 7, 50, 53, 56
FORK# CUBE CSL Race, One Piece 3D Forged Steerer/Crown, Carbon Blades, 1 1/8" - 1 1/4" Tapered

HEADSET# SA Z-t, Top Zero-Stack 1 1/8" (OD 44mm), Bottom Integrated 1 1/4"
STEM# CUBE Performance Stem Pro, 31.8mm
HANDLEBAR# CUBE Compact Race Bar
HANDLEBAR TAPE# CUBE Grip Control
REAR DERAILLEUR# Shimano Claris RD-R2000-GS, 8-Speed
FRONT DERAILLEUR# Shimano Claris FD-R2000-BM, 31.8mm
SHIFT/ BRAKE LEVERS# Shimano Claris ST-R2000
BRAKE SYSTEM# Shimano Claris BR-R2000
CRANKSET# Shimano Claris FC-R2000, 50x34T, BB-RS500, 170mm
CASSETTE# Shimano CS-HG31, 11-34T
CHAIN# MC Z7
WHEELSET# CUBE RA 0.8 Aero, QR/QR
TYRES# Conti Ultra Sport 2, 25-622
SADDLE# Natural Fit Venec Lite WS
SEAT POST# CUBE Performance Post, 27.2mm
SEATCLAMP# CUBE Screwlock, 31.8mm

WEIGHT# 4 kg

SPARE PARTS#
10151 CUBE Hanger #151 for Attain/Agree MY2016
10359 CUBE Headset FSA Z-t, Top Zero-Stack 1 1/8" (OD 44mm)
13552 Inner Tube 28" ROAD SV 60 mm
33043 CUBE Natural Fit Bar Tape Grip

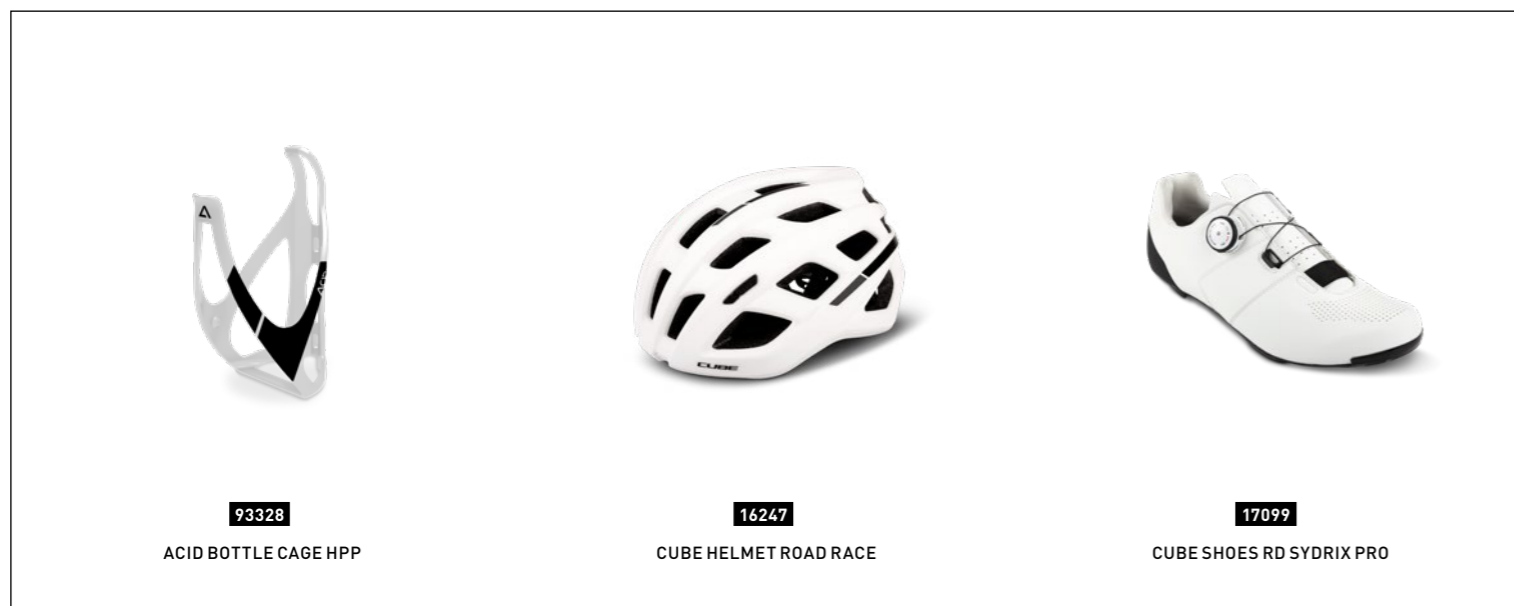

93328
ACID BOTTLE CAGE HPP

16247
CUBE HELMET ROAD RACE

17099
CUBE SHOES RD SYDRIX PRO

FOR us #Adventurers

When we set out to develop the Nuroad WS we had a destination in mind, but no specific route by which to get there. We did, however, have a lot of experience building great race and cyclocross bikes. Figuring that this would be a great place to start, we combined the best of both genres to create our new, super-adaptable all-rounder. So, for example, the Nuroad WS's geometry is based on the comfort, stability and agility of our Attain WS series. We made sure there's plenty of clearance to run wide, grippy and comfortable tyres up to 40mm in width, and even left room for mudguards with 35mm tyres too. Internal cable routing keeps your gears shifting cleanly even when the mud and water's flying around, there's a replaceable gear hanger and the carbon fork blades help take some of the vibration out of rough surfaces, so that you stay comfortable even on long rides.



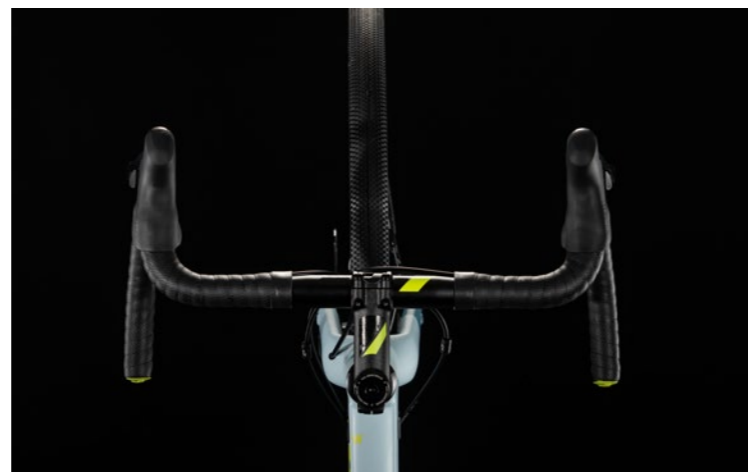



Roads aren't always smooth, and adventure doesn't have limits. These were our thoughts when we set out to build the Nuroad WS – a bike that will allow you to keep riding where other road bikes fear to tread. Nimble, adaptable and rugged enough to take tarmac, gravel, mud and just about any surface you care to mention in its stride, it'll open your eyes to new possibilities. The purpose-designed aluminium frame combines the DNA of our road and cyclocross bikes to create our new all-rounder. So, for example, the geometry is based on the comfort, stability and agility of our Attain WS series. We made sure there's plenty of clearance to run wide, grippy and comfortable tyres up to 40mm in width, and even left room for mudguards with 35mm tyres too. And carbon fork blades take the buzz out of the worst road surfaces, so you can keep riding when the tarmac stops. Shimano's reliable Tiagra 2x10 speed transmission puts the right gear for any eventuality at your fingertips, and Tektro Spyre disc brakes offer ample all-weather stopping power. The only question is, where will your next ride take you?

-  **FRAME#**Aluminium 6061 T6 Superlite, Gravel Comfort Geometry, Flat Mount Disc, Fender & Rack Option, 12x142mm, AXH
- SIZE#**50, 53, 56, 58
- FORK#**CUBE Nuroad Disc, One Piece 3D-Forged Steerer/Crown, Carbon Blades, 1 1/8" - 1 1/2" Tapered, Flat Mount, 12x100mm

-  **HEADSET#**SA Orbit Z-t ECO, Top Zero-Stack 1 1/8" (OD 44mm), Bottom Integrated 1 1/2"
- STEM#**CUBE Performance Stem Pro, 31.8mm
- HANDLEBAR#**CUBE Gravel Race Bar
- HANDLEBAR TAPE#**CUBE Grip Control
- REAR DERAILLEUR#**Shimano Tiagra RD-4700GS, 10-Speed
- FRONT DERAILLEUR#**Shimano Tiagra FD-4700, 31.8mm Clamp
- SHIFT/ BRAKE LEVERS#**Shimano Tiagra ST-4700
- BRAKE SYSTEM#**RP Spyre MD-C610C, Flat Mount
- CRANKSET#**Shimano Tiagra FC-4700, 50x34T, 170mm (50/53cm), 172.5mm (56/58cm)
- CASSETTE#**Shimano CS-HG500, 11-34T
- CHAIN#**MC X10
- WHEELSET#**CUBE RA 0.8 CX
- TYRES#**Schwalbe G-One Allround, Kevlar, 40-622
- SADDLE#**Natural Fit Venec Lite WS
- SEAT POST#**CUBE Performance Post, 27.2mm
- SEATCLAMP#**CUBE Screwlock, 31.8mm

-  **WEIGHT#**0,7 kg



-  **SPARE PARTS#**
- 10240** CUBE Hanger 2090 AXH
- 13550** Inner Tube 28" TREKKING SV 40 mm
- 33043** CUBE Natural Fit Bar Tape Grip

T O U R



COMFORT
COMFORT

TOUR
TOUR

SPORT
SPORT

288	CROSS			
300	NATURE			
308	KATHMANDU			
314	TOURING			
328	TRAVEL			

CROSS

Cross by name, adaptable by nature. Light, nimble and equipped to be reliable and versatile, the Cross is your fast and comfortable companion for everything from urban rat-runs to rural adventures. With Smooth Welding and ultra-neat rack and mudguard mounts, it's also a real looker.

NATURE

Get out more. With the Nature's low weight, easy handling, ride-all-day comfort and reliable components, bicycle-powered adventures starting from your doorstep are there for the taking. With powerful disc brakes and the comfort of a suspension fork, there's nothing to stop you...

KATHMANDU

Feed your curiosity. The Kathmandu is our rugged, go-anywhere tourer - built to take on a weekend ride through a national park or tour across a mountain range. Fully equipped with everything you need for a nomadic life on the road, just add a tent, stove and sleeping bag for instant adventure.

TOURING

Nothing lifts the spirits like freewheeling down country lanes - and that's what the Touring was built for. Light, comfortable, easy to use and fully equipped with carrier, lights, mudguards and kickstand, it's got .let's go for a picnic this weekend' written all over it. Not literally, of course...

TRAVEL

If travel broadens the mind - and we think that it does - then this is a mind-expanding bike. Light, comfortable, nimble and rugged, we've kitted out the Travel with rack, guards and lights so that you can feed your curiosity. Live more adventurously, ride more frequently - and add a Travel to your life.

FOR us #Explorers

When they set out to design the Cross's aluminium frame, our engineers set themselves an ambitious goal: to increase efficiency, stability and riding comfort, all whilst reducing weight. That's why you'll find technologies in the Cross frame that ordinarily belong in much more expensive bikes. Whether it's the Smooth Welding technology we've employed to improve the appearance of frame joints or the sleek, double-buttressed aluminium tubes and neatly integrated luggage carrier and mudguard mounts, everything is here to improve both function and looks. A tapered head tube improves steering precision, while cables routed inside the down tube help keep your gears shifting smoothly for longer, with minimal maintenance.



CROSS SL

345450 | Trapeze | blue'n'lime



CROSS SL

345450 | blue'n'lime

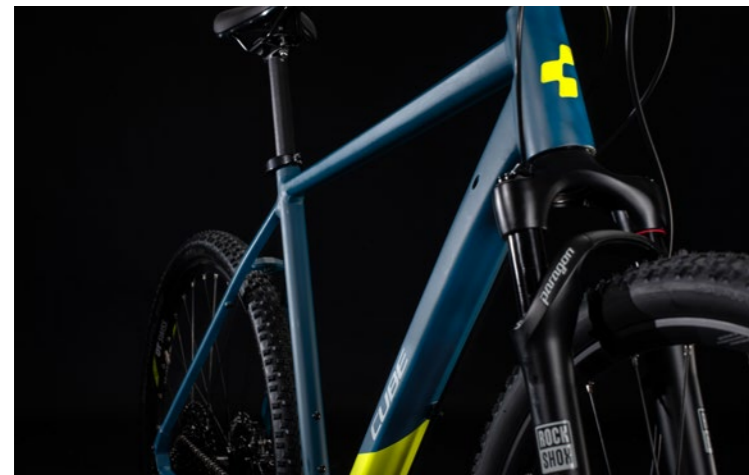

If your attitude to riding is that there's no road too long and no mountain too steep, you know you've caught the bug – and that you need a bike to fuel your passion. The Cross SL is a no-compromise, light, lively and adaptable machine that sets a new benchmark for low weight and premium quality. Pairing only the finest components with a frame designed for speed and comfort, our engineers and designers didn't settle for anything less than the best in their quest to build the ultimate all-rounder. The double-butted aluminium chassis – made with our own premium-quality tubes – is packed full of technical highlights like Smooth Welding for an almost organic look, a tapered head tube for the ultimate in strength, stiffness and steering precision, and sophisticated RLink carrier compatibility. The Sram 1x12 transmission offers an incredibly wide gear range, low weight and unmatched ease of use. Paired with Shimano XT hydraulic disc brakes and grippy Schwalbe Smart Sam tyres, it's the best way of staying in control on your adventures. Throw in the RockShox Paragon Gold air-sprung suspension fork for mile-munching comfort, and it's hard to see how we could improve on the Cross SL. It's in a class of one.

FRAME Aluminium Superlite Trekking Cross Taper Double Butted
SIZE Men: 46, 50, 54, 58, 62, Trapeze: 46, 50, 54
FORK RockShox Paragon Gold RMT Taper, 65mm, Lockout

HEADSET SA Orbit I-t, Integrated, Top 1 1/8", Bottom 1 1/2"
STEM Newmen Evolution 318.4, 31.8mm
HANDLEBAR Newmen Advanced 318.0, Carbon, 740mm
GRIPS Natural Fit All Terrain
REAR DERAILLEUR Sram GX Eagle™, 12-Speed
SHIFTERS Sram GX Eagle™ Trigger
BRAKE SYSTEM Shimano XT BR-M8100, Hydr. Disc Brake (180/160)
CRANKSET Sram X1 Eagle™ DUB, 38T, 175mm
CASSETTE Sram XG-1230, 11-50T
CHAIN Sram NX Eagle™
WHEELSET DT Swiss CSW MA 1.9, QR/QR, 32H/28H,
TYRES Schwalbe Smart Sam, Performance Kevlar, 47-622
PEDALS CUBE Aluminium MTB
SADDLE Natural Fit Sequence+
SEAT POST CUBE Performance Post, 27.2mm
SEATCLAMP CUBE Varioclose, 31.8mm

WEIGHT #1.7 kg

SPARE PARTS#
10148 CUBE Hanger #148 short version
10339 CUBE Headset Orbit I-T + 1 1/8 crown race
13550 Inner Tube 28" TREKKING SV 40 mm

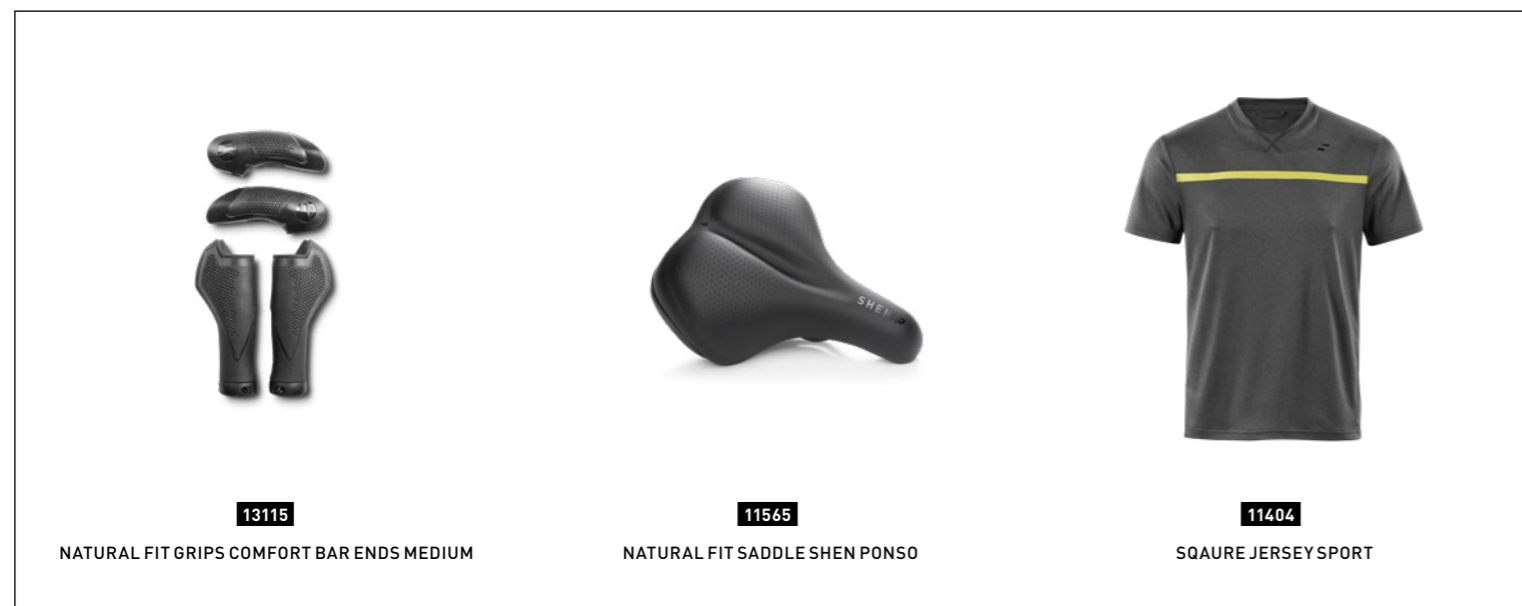

13115

NATURAL FIT GRIPS COMFORT BAR ENDS MEDIUM



11565

NATURAL FIT SADDLE SHEN PONSO



11404

SQAURE JERSEY SPORT

CROSS EXC

345400 | Trapeze | iridium 'n' white



CROSS EXC

345400 | iridium 'n' white



You know how it is – you're out for a ride and you just can't help taking the long route home, or trying out the turning you've never been down before. If that sounds like you, may we introduce you to the Cross EXC? A high-quality, lightweight aluminium chassis, superb RockShox Paragon Gold air suspension fork and Shimano XT transmission with hydraulic disc brakes mean you've everything you need at your fingertips for longer, more adventurous rides. Our engineering team's approach to the frame was uncompromising – their goal was to make the most efficient, stable and comfortable touring frame possible. To that end, they borrowed technologies and design cues from our mountain bike range. So, for example, the double-butted aluminium tubeset reduces weight without sacrificing strength, while the tapered head tube increases rigidity and steering accuracy – and Smooth Welding technology keeps the whole thing incredibly neat. We even designed the RILink carrier and mudguard mounts to be almost invisible, so you can accessorise your Cross EXC to meet your needs without spoiling its great looks. Whether you're inspired by the idea of more adventurous routes or just want a bike that's as reliable as it is fun to ride, choose the Cross EXC... and ride like you mean it.

-  **FRAME** #Aluminium Superlite Trekking Cross Taper Double Butted
- SIZE** #Men: 46, 50, 54, 58, 62, Trapeze: 46, 50, 54
- FORK** #RockShox Paragon Gold Taper, 65mm, Lockout

-  **HEADSET** #SA Orbit I-t, Integrated, Top 1 1/8", Bottom 1 1/2"
- STEM** #CUBE Performance Stem Pro, 31.8mm
- HANDLEBAR** #CUBE Rise Trail Bar, 680mm
- GRIPS** #Natural Fit All Terrain
- REAR DERAILLEUR** #Shimano XT RD-T8000, 10-Speed
- SHIFTERS** #Shimano XT SL-T8000
- FRONT DERAILLEUR** #Shimano XT FD-T8000, Top Swing, 31.8mm Clamp
- BRAKE SYSTEM** #Shimano XT BR-M8100, Hydr. Disc Brake (180/160)
- CRANKSET** #Shimano XT FC-T8000, Hollowtech II, 48x36x26T, 175mm, Integrated BB, Chainguard
- CASSETTE** #Shimano CS-M771, 11-34T
- CHAIN** #Shimano CN-HG95
- RIMS** #CUBE EX21, 32H, Disc, Tubeless Ready
- FRONT HUB** #Shimano XT HB-M8000, QR, Centerlock
- REAR HUB** #Shimano XT FH-M8000, QR, Centerlock
- TYRES** #Schwalbe Smart Sam, Performance Kevlar, 47-622
- PEDALS** #CUBE PP MTB
- SADDLE** #Natural Fit Sequence+
- SEAT POST** #CUBE Performance Post, 27.2mm
- SEATCLAMP** #CUBE Varioclose, 31.8mm

-  **WEIGHT** #1,9 kg

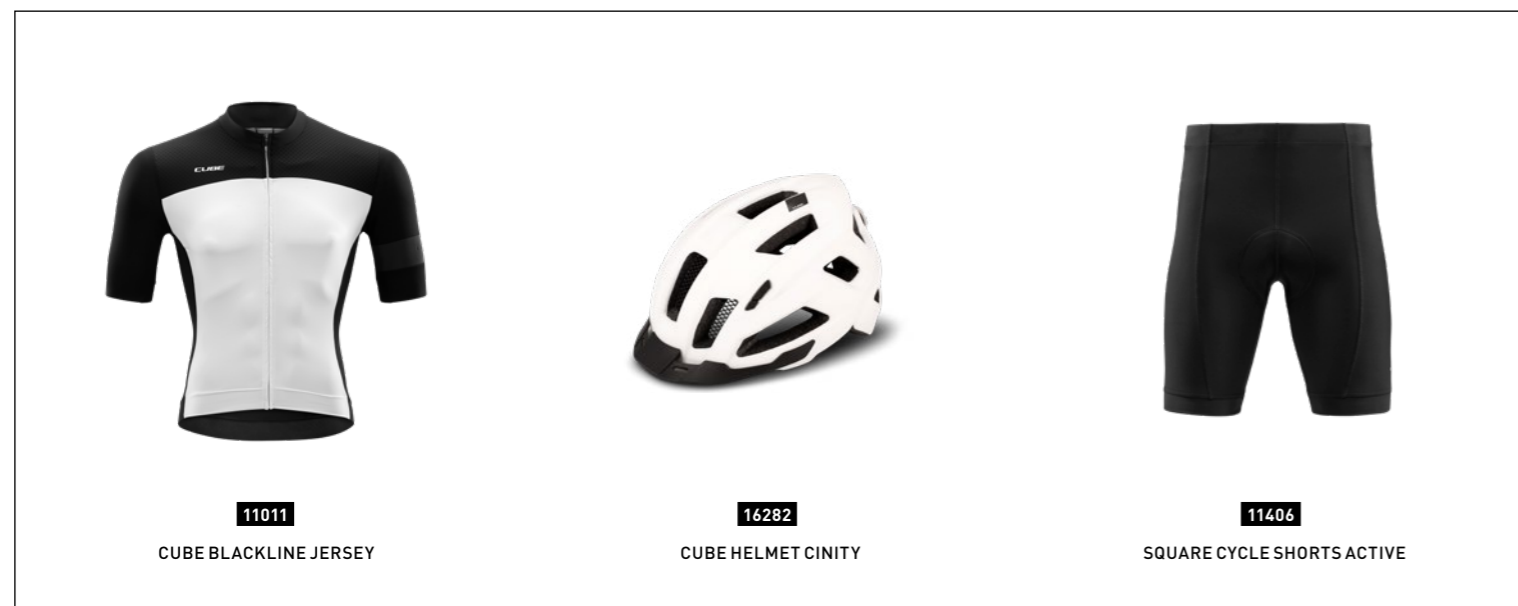

11011
CUBE BLACKLINE JERSEY



16282
CUBE HELMET CINITY



11406
SQUARE CYCLE SHORTS ACTIVE

-  **SPARE PARTS**
- 10148** CUBE Hanger #148 short version
- 10339** CUBE Headset Orbit I-T + 1 1/8 crown race
- 14204** RFR X10 - 73G Chain

CROSS PRO

345350 | iridium'n'green



CROSS PRO

345360 | blue'n'red



345350 | Trapeze | iridium'n'green





345360 | Trapeze | blue'n'red



The whole point of a bike, as far as we're concerned, is to inspire adventure. The Cross Pro's rugged design and versatile equipment means that you won't have to turn around in a dead-end street if the way ahead is a dirt road – and isn't that exactly the kind of thing that adventure is all about? Borrowing features inspired by our mountain bike frames, the Cross Pro's light chassis boasts double-butted tubes for lighter weight, a tapered head tube for precise steering and internally routed gear cables for long-lasting, smooth gear shifts. It's also RILink carrier compatible, with mounting points hidden out of the way inside the rear dropouts – a superb system that allows for full mudguards and a luggage carrier to be fitted neatly and unobtrusively. The easily adjustable, air-sprung RockShox fork smooths out the lumps and bumps of adventurous travel, while powerful Shimano hydraulic disc brakes ensure you're always in control. And, of course, we selected Shimano's super-reliable, easy-to-use Deore 10-speed components for a wide range of gears to tackle any situation. It's the Swiss Army Knife of bikes – ready to take on anything, wherever you find yourself.

-  **FRAME** #Aluminium Superlite Trekking Cross Taper Double Butted
- SIZE** #Men: 46, 50, 54, 58, 62, Trapeze: 46, 50, 54
- FORK** #RockShox Paragon Gold Taper, 65mm, Lockout

-  **HEADSET** #SA Orbit I-t, Integrated, Top 1 1/8", Bottom 1 1/2"
- STEM** #CUBE Performance Stem Pro, 31.8mm
- HANDLEBAR** #CUBE Rise Trail Bar, 680mm
- GRIPS** #Natural Fit All Terrain
- REAR DERAILLEUR** #Shimano XT RD-T8000, 10-Speed
- SHIFTERS** #Shimano Deore SL-M6000, Rapidfire-Plus
- FRONT DERAILLEUR** #Shimano XT FD-T8000, Top Swing, 31.8mm Clamp
- BRAKE SYSTEM** #Shimano BR-MT200, Hydr. Disc Brake (180/160)
- CRANKSET** #Shimano XT FC-T8000, Hollowtech II, 48x36x26T, 175mm, Integrated BB, Chainguard
- CASSETTE** #Shimano CS-HG500, 11-34T
- CHAIN** #MC X10
- RIMS** #CUBE EX21, 32H, Disc, Tubeless Ready
- FRONT HUB** #Shimano HB-M4050
- REAR HUB** #Shimano FH-M4050
- TYRES** #Schwalbe Smart Sam, Active, Skinwall, 47-622
- PEDALS** #CUBE PP MTB
- SADDLE** #Natural Fit Sequence+
- SEAT POST** #CUBE Performance Post, 27.2mm
- SEATCLAMP** #CUBE Varioclose, 31.8mm

 **WEIGHT** #2,4 kg



13329

ACID CHAIN LOCK CORVID K100



12959

CUBE BOTTLE GRIP 0.75L



13019

CUBE BOTTLE CAGE HPP

SPARE PARTS#

- 10148** CUBE Hanger #148 short version
- 10339** CUBE Headset Orbit I-T + 1 1/8 crown race
- 14204** RFR X10 - 73G Chain

CROSS ALLROAD

346300 | Trapeze | iridium'n'green



CROSS ALLROAD

346300 | iridium'n'green



Some people will tell you that one bike can't do it all. All we can say is, they clearly haven't tried the Cross Allroad. Because this bike redefines versatility. Blending the sophisticated frame design of our Cross series with the added functionality of full-length mudguards and a built-in rear light and hub dynamo, this is a bike that's capable of tackling everything from the daily commute to extended weekend excursions. From the organic appearance of the Smooth Welding joints at the tapered head tube to the low-maintenance internal cable routing and RILink compatible carrier mounts, every detail is designed to enhance comfort, strength, durability and appearance. Shimano's slick, reliable 10-speed transmission is backed by the powerful all-weather stopping ability of hydraulic disc brakes and the comfort of a Suntour suspension fork. All roads, all weather, all seasons, all purposes: the Cross Allroad is the bike for all reasons.

- FRAME** Aluminium Superlite Trekking Cross Double Butted
- SIZE** Men: 46, 50, 54, 58, 62, Trapeze: 46, 50, 54
- FORK** Suntour NCX D LO Air, 63mm

- HEADSET** SA Orbit I-t, Integrated, Top 1 1/8", Bottom 1 1/2"
- STEM** CUBE Performance Stem Pro, 31.8mm
- HANDLEBAR** CUBE Rise Trail Bar, 680mm
- GRIPS** Natural Fit All Terrain
- REAR DERAILLEUR** Shimano XT RD-T8000, 10-Speed
- SHIFTERS** Shimano Deore SL-M6000, Rapidfire-Plus
- FRONT DERAILLEUR** Shimano Deore FD-T6000, Top-Swing, 31.8mm
- BRAKE SYSTEM** Shimano BR-MT200, Hydr. Disc Brake (160/160)
- CRANKSET** Shimano XT FC-T8000, Hollowtech II, 48x36x26T, 175mm, Integrated BB, Chainguard
- CASSETTE** Shimano CS-HG500, 11-34T
- CHAIN** MC X10
- RIMS** CUBE ZX20, 32H, Disc
- FRONT HUB** Shimano DH-3D37, Hub Dynamo, QR, Centerlock
- REAR HUB** Shimano Alivio FH-M4050
- TYRES** Schwalbe Land Cruiser, Active, 47x622
- PEDALS** CUBE PP MTB
- SADDLE** Natural Fit Sequence+
- SEAT POST** CUBE Performance Post, 27.2mm
- SEATCLAMP** CUBE Varioclose, 31.8mm
- FRONT LIGHT** Busch&Müller Lumotec IQ-XS N Plus
- REAR LIGHT** Busch&Müller Xeltec
- KICKSTAND** CUBEstand Pro, Adjustable
- MUDGUARDS** CID 53
- BELL** Knog Oi

WEIGHT 4,6 kg

- SPARE PARTS#**
- 10148** CUBE Hanger #148 short version
- 10324** CUBE Headset Orbit Z
- 14204** RFR X10 - 73G Chain



92378
ACID PEDALS COMBO A4-1B HYBRID

93100
ACID PANNIERS TRAVLR 15

92048
ACID REAR CARRIER SIC 28" RILINK

NATURE EXC

345200 black 'n' red



NATURE EXC

345210 green 'n' orange



345200 | Trapeze black 'n' red





345210 | Trapeze green 'n' orange



The Nature EXC is designed for riders who like to explore off the beaten path. We gave our design team a brief to build a sporty, reliable bike with well-balanced handling, great equipment and the best possible safety. It's safe to say they came up trumps. With its high quality, lightweight aluminium frame, lockout-equipped Suntour suspension fork and 3x10 Shimano transmission, this is a bike that simply excels. Neat touches like the double-butted frame tubing – which saves weight without sacrificing strength – and internal gear cable routing – for cleaner looks and more reliable gear shifting – are typical of the attention to detail that our design team lavishes on every one of our bikes. Grippy tyres and powerful hydraulic disc brakes give you the power and confidence to control your speed in any weather conditions, and the entire bike has survived the usual CUBE torture-testing regime in our in-house lab, so you can be sure that it's one of the safest bikes out there. Whether you use it for fitness and fun, or as a workhorse companion to help you keep pace with your busy life, the Nature EXC will get you where you need to go in comfort and style.

-  **FRAME** #Aluminium Superlite Trekking Cross Double Butted
- SIZE** #Men: 46, 50, 54, 58, 62, Trapeze: 46, 50, 54
- FORK** #SR Suntour NEX HLO, 63mm

-  **HEADSET** #CUBE FPH863, Semi-Integrated
- STEM** #CUBE Performance Stem Pro, 31.8mm
- HANDLEBAR** #CUBE Rise Trail Bar, 680mm
- GRIPS** #Natural Fit All Terrain
- REAR DERAILLEUR** #Shimano XT RD-T8000, 10-Speed
- SHIFTERS** #Shimano Deore SL-M6000, Rapidfire-Plus
- FRONT DERAILLEUR** #Shimano Deore FD-T6000, Top-Swing, 31.8mm
- BRAKE SYSTEM** #Shimano BR-MT200, Hydr. Disc Brake (160/160)
- CRANKSET** #Shimano FC-T521, 48x36x26T, Octalink, BB-ES300, 175mm, Chainguard
- CASSETTE** #Shimano CS-HG500, 11-34T
- CHAIN** #MC X10
- RIMS** #CUBE ZX20, 32H, Disc
- FRONT HUB** #Shimano HB-TX505, QR, Centerlock
- REAR HUB** #Shimano FH-TX505, QR, Centerlock
- TYRES** #Schwalbe Land Cruiser, Active, 47x622
- PEDALS** #CUBE PP MTB
- SADDLE** #Natural Fit Sequence
- SEAT POST** #CUBE Performance Post, 27.2mm
- SEATCLAMP** #CUBE Varioclose, 31.8mm

-  **WEIGHT** #3,4 kg



11408

SQAURE BAGGY SHORTS ACTIVE



11967

CUBE GLOVES WS X NF



11061

SQUARE JERSEY PERFORMANCE

-  **SPARE PARTS**
- 10148** CUBE Hanger #148 short version
- 10324** CUBE Headset Orbit Z
- 13548** Inner Tube 28" TREKKING AGV 40 mm

NATURE EXC ALLROAD

346200 black'n'red



NATURE EXC ALLROAD

346210 green'n'orange



346200 | Trapeze black'n'red



346210 | Trapeze green'n'orange



The Nature EXC Allroad is an all-season, all-weather bike that's designed to inspire you to get out and ride, whatever the conditions. After all, a rainy commute in November can define two-wheeled freedom just as well as a weekend ride that finishes at sunset on a balmy summer evening. Don't believe us? Check out the comfort-enhancing Suntour suspension fork, the full-length mudguards with integrated rear light and the smooth, powerful hydraulic disc brakes. The frame borrows features like internal cable routing, weight-saving double-butted tubing and RILink carrier compatibility from our higher-end bikes and, of course, it's passed our in-house safety tests in our purpose-built lab with flying colours, so you can rest assured that it's strong, safe and durable. Add the slick precision and superior reliability of Shimano's 10-speed transmission, there's really no reason not to ride. Great looks, great performance and great everyday practicality: that's the Nature EXC Allroad.

- FRAME** Aluminium Superlite Trekking Cross Double Butted
- SIZE** Men: 46, 50, 54, 58, 62, Trapeze: 46, 50, 54
- FORK** Suntour NEX HLO, 63mm
- HEADSET** CUBE FPH863, Semi-Integrated
- STEM** CUBE Performance Stem Pro, 31.8mm
- HANDLEBAR** CUBE Rise Trail Bar, 680mm
- GRIPS** Natural Fit All Terrain
- REAR DERAILLEUR** Shimano XT RD-T8000, 10-Speed
- SHIFTERS** Shimano Deore SL-M6000, Rapidfire-Plus
- FRONT DERAILLEUR** Shimano Deore FD-T6000, Top-Swing, 31.8mm
- BRAKE SYSTEM** Shimano BR-MT200, Hydr. Disc Brake (160/160)
- CRANKSET** Shimano FC-T521, 48x36x26T, Octalink, BB-ES300, 175mm, Chainguard
- CASSETTE** Shimano CS-HG500, 11-34T
- CHAIN** MC X10
- RIMS** CUBE ZX20, 32H, Disc
- FRONT HUB** Shimano DH-3D37, Hub Dynamo, QR, Centerlock
- REAR HUB** Shimano FH-TX505, QR, Centerlock
- TYRES** Schwalbe Land Cruiser, Active, 47x622
- PEDALS** CUBE PP MTB
- SADDLE** Natural Fit Sequence
- SEAT POST** CUBE Performance Post, 27.2mm
- SEATCLAMP** CUBE Varioclose, 31.8mm
- FRONT LIGHT** AXA Compactline 20, AC
- REAR LIGHT** Busch&Müller Xeltec
- KICKSTAND** CUBEstand Pro, Adjustable
- MUDGUARDS** CID 53
- BELL** Mini Bell

WEIGHT 5,4 kg

- SPARE PARTS**
- 10148 CUBE Hanger #148 short version
- 10324 CUBE Headset Orbit Z
- 14204 RFR X10 - 73G Chain



17091

CUBE SHOES ATX LOXIA PRO



11059

SQUARE JERSEY ACTIVE



14180

CUBE HELMET STEEP



NATURE PRO

345150 | Trapeze | grey'n'white



NATURE PRO

345150 | grey'n'white



The Nature Pro is proof that a reliable, robust bike doesn't have to be boring – it can also be huge fun to ride. Built around a high-quality aluminium frame and fitted with a Suntour suspension fork with lockout, it's rugged enough to withstand the rigours of everyday use, so you can concentrate on enjoying the ride. Neat rack and mudguard mounting points are almost invisible and allow a RiLink carrier to be fitted, which means you can easily transform your bike into a versatile and elegant load carrier. We fitted powerful, easy-to-use hydraulic disc brakes for the best possible weather-proof stopping power, so you can ride safely even in wet conditions. And, with grippy and fast-rolling Schwalbe Smart Sam tyres and a smooth-shifting, wide-ranging Shimano transmission, you've everything you need to tackle anything from a ride out on quiet country lanes to nipping across town. Add it all up, and it's the ideal machine for weekend and fitness cyclists – and there's even a trapeze frame option for women who prefer that configuration for easier mounting and dismounting. Just add your spirit of adventure, and you're all set to go.

FRAME #Aluminium Superlite Trekking Cross Double Butted
SIZE #Men: 46, 50, 54, 58, 62, Trapeze: 46, 50, 54
FORK #R Suntour NEX HLO, 63mm

HEADSET #CUBE FPH863, Semi-Integrated
STEM #CUBE Performance Stem Pro, 31.8mm
HANDLEBAR #CUBE Rise Trail Bar, 680mm
GRIPS #Natural Fit All Terrain
REAR DERAILLEUR #Shimano Deore RD-M592, 9-Speed
SHIFTERS #Shimano SL-M3000, Rapidfire-Plus
FRONT DERAILLEUR #Shimano FD-T3000, Topswing, 31.8mm
BRAKE SYSTEM #Shimano BR-MT200, Hydr. Disc Brake (160/160)
CRANKSET #Shimano Acera FC-M371, 48x36x26T, 175mm, Chainguard
CASSETTE #Shimano CS-HG200, 11-34T
CHAIN #MC X9
RIMS #CUBE ZX20, 32H, Disc
FRONT HUB #Shimano HB-TX505, QR, Centerlock
REAR HUB #Shimano FH-TX505, QR, Centerlock
TYRES #Schwalbe Smart Sam, Active, 47-622
PEDALS #CUBE PP MTB
SADDLE #Natural Fit Sequence
SEAT POST #CUBE Performance Post, 27.2mm
SEATCLAMP #CUBE Varioclose, 31.8mm

WEIGHT #3,8 kg

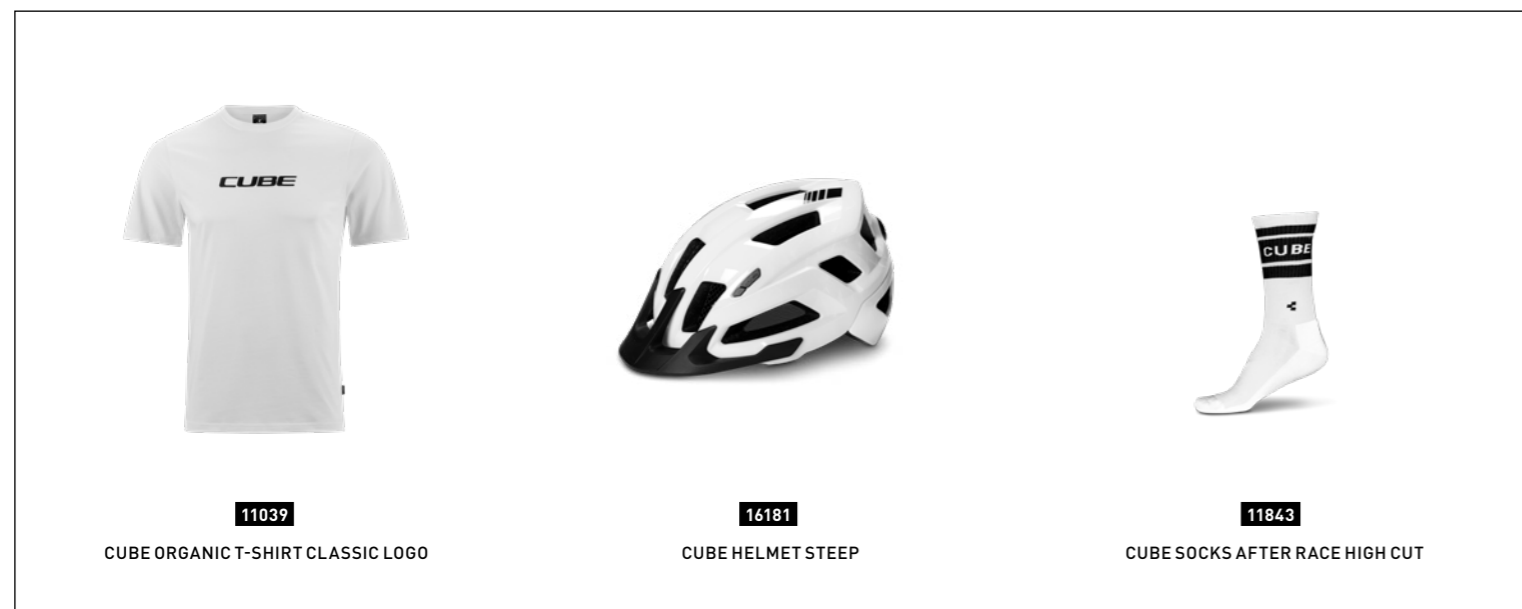

11039
CUBE ORGANIC T-SHIRT CLASSIC LOGO

16181
CUBE HELMET STEEP

11843
CUBE SOCKS AFTER RACE HIGH CUT

SPARE PARTS
10148 CUBE Hanger #148 short version
10324 CUBE Headset Orbit Z
13548 Inner Tube 28" TREKKING AGV 40 mm

NATURE

345100 iridium 'n' blue



NATURE

345110 red 'n' grey



345100 | Trapeze iridium 'n' blue





345110 | Trapeze red 'n' grey



A gentle breeze on your face, the open road beckoning and a spirit of adventure – freedom on two wheels. The Nature is your perfect introduction to a world of exploration and opportunity. Whether you need a bike for getting around town or exploring further afield at the weekend, this is the tool for the job. Built with comfort and reliability in mind, it's got all the attention to detail you'd expect from CUBE at a price that may surprise you. The frame, for example, features double-butted tubing – a process that removes material where it's not needed, to save weight without sacrificing strength. Internally routed cables keep your gear shifts smooth and precise with absolutely minimal maintenance. The Suntour suspension fork helps smooth out potholed roads, while a full range of 24 Shimano gears means you'll always be able to find the right gear for any occasion. And we even fitted powerful hydraulic disc brakes, for dependable all-weather stopping. And, of course, the complete bike has passed our extremely stringent in-house safety tests – so you can be confident that your Nature will get you to your destination in style and complete safety.

-  **FRAME** #Aluminium Superlite Trekking Cross Double Butted
- SIZE** #Men: 46, 50, 54, 58, 62, Trapeze: 46, 50, 54
- FORK** #SR Suntour NEX, 63mm

-  **HEADSET** #CUBE FPH863, Semi-Integrated
- STEM** #CUBE Performance Stem, 31.8mm
- HANDLEBAR** #CUBE Rise Trail Bar, 680mm
- GRIPS** #CUBE Performance Grip
- REAR DERAILLEUR** #Shimano RD-M360, 8-Speed
- SHIFTERS** #Shimano SL-M315, Rapidfire Plus
- FRONT DERAILLEUR** #Shimano FD-TX800, Topswing, 31.8mm Clamp
- BRAKE SYSTEM** #ektro HD-M275, Hydr. Disc Brake, (160/160)
- CRANKSET** #Shimano FC-TX801, 48x38x28T, BB-UN100, 170mm, Chainguard
- CASSETTE** #Shimano CS-HG200, 12-32T
- CHAIN** #MC Z72
- RIMS** #CUBE ZX20, 32H, Disc
- FRONT HUB** #CUBE K68F Alloy Light
- REAR HUB** #CUBE K68R Alloy Light
- TYRES** #CUBE IMPAC Streetpac, 42-622
- PEDALS** #CUBE PP MTB
- SADDLE** #Natural Fit Venec Lite
- SEAT POST** #CUBE Performance Post, 27.2mm
- SEATCLAMP** #CUBE Varioclose, 31.8mm

-  **WEIGHT** #3,9 kg



11967

CUBE GLOVES WS X NF



16180

CUBE HELMET STEEP



11276

CUBE TOUR JERSEY

-  **SPARE PARTS**
- 13548** Inner Tube 28" TREKKING AGV 40 mm
- 10148** CUBE Hanger #148 short version
- 10324** CUBE Headset Orbit Z

NATURE ALLROAD

346100 | iridium 'n' blue



NATURE ALLROAD

346110 | red 'n' grey



346100 | Trapeze | iridium 'n' blue





346110 | Trapeze | red 'n' grey



Whether it's a business meeting that's overrun or a weekend ride that ends up taking you further than you expected, the Nature Allroad can handle it – urban mobility and rural freedom, all rolled into a safe, stable and easy-to-use package. Its state-of-the-art frame is a masterpiece of practical, functional engineering. Double-butted aluminium tubes save weight without sacrificing strength, and RILink compatible carrier mounts tuck neatly inside the rear dropout area so that everyday accessories don't spoil your Nature Allroad's good looks. With features like a comfortable Suntour suspension fork to iron out the bumps in the road, powerful hydraulic disc brakes for safe all-weather stopping, mudguards with a built-in rear light, Easy Mount kickstand and smooth, reliable Shimano gears, the daily commute is going to be a pleasure rather than a chore. And, with its light, responsive frame and easy luggage carrier upgrade, it's all the bike you'll need for weekend fun, too. All of which goes to show that practical doesn't have to be boring...

-  **FRAME** #Aluminium Superlite Trekking Cross Double Butted
- SIZE** #Men: 46, 50, 54, 58, 62, Trapeze: 46, 50, 54
- FORK** #SR Suntour NEX HLO, 63mm

-  **HEADSET** #CUBE FPH863, Semi-Integrated
- STEM** #CUBE Performance Stem Pro, 31.8mm
- HANDLEBAR** #CUBE Rise Trail Bar, 680mm
- GRIPS** #CUBE Performance Grip
- REAR DERAILLEUR** #Shimano RD-M360, 8-Speed
- SHIFTERS** #Shimano SL-M315, Rapidfire Plus
- FRONT DERAILLEUR** #Shimano FD-M310, Topswing, 31.8mm
- BRAKE SYSTEM** #Shimano BR-MT200, Hydr. Disc Brake (160/160)
- CRANKSET** #Shimano FC-T801, 48x36x26T, 175mm, Chainguard
- CASSETTE** #Shimano CS-HG31, 11-34T
- CHAIN** #MC Z51
- RIMS** #CUBE ZX20, 32H, Disc
- FRONT HUB** #Shimano DH-3D37, Hub Dynamo, QR, Centerlock
- REAR HUB** #Shimano FH-TX505, QR, Centerlock
- TYRES** #Schwalbe Land Cruiser, Active, 47x622
- PEDALS** #CUBE PP MTB
- SADDLE** #Natural Fit Sequence
- SEAT POST** #CUBE Performance Post, 27.2mm
- SEATCLAMP** #CUBE Varioclose, 31.8mm
- FRONT LIGHT** #AXA Compactline 20, AC
- REAR LIGHT** #Busch&Müller Xeltec
- KICKSTAND** #CUBEstand Cmpt
- MUDGUARDS** #ACID 53
- BELL** #Mini Bell

 **WEIGHT** #5,6 kg

-  **SPARE PARTS**
- 10148** CUBE Hanger #148 short version
- 10324** CUBE Headset Orbit Z
- 13548** Inner Tube 28" TREKKING AGV 40 mm



92048
ACID REAR CARRIER SIC 28" RILINK



16284
CUBE HELMET CINIY



11940
CUBE GLOVES X NF

FOR us #Travellers

You can't broaden the mind if you're not comfortable. That's why the Kathmandu is built with our renowned Efficient Comfort Geometry, which puts you in the optimum position for the best blend of comfort and performance – mile after mile after mile. Lightweight double-butted tubing saves weight where possible and maintains stiffness and strength where needed, so the Kathmandu remains stable and predictable on any road, and carrying any load. Speaking of which, our engineers are particularly proud of the IC 2.0 luggage carrier, which combines sleek looks with exceptional strength, rigidity and ease of use. And neat touches like cables routed inside the down tube and a kickstand mounted directly to the rear dropout mean you can be assured we've thought of everything. Just don't forget to pack your toothbrush...



KATHMANDU SL

348400 | Trapeze | black'n'green



KATHMANDU SL

348400 | black'n'green

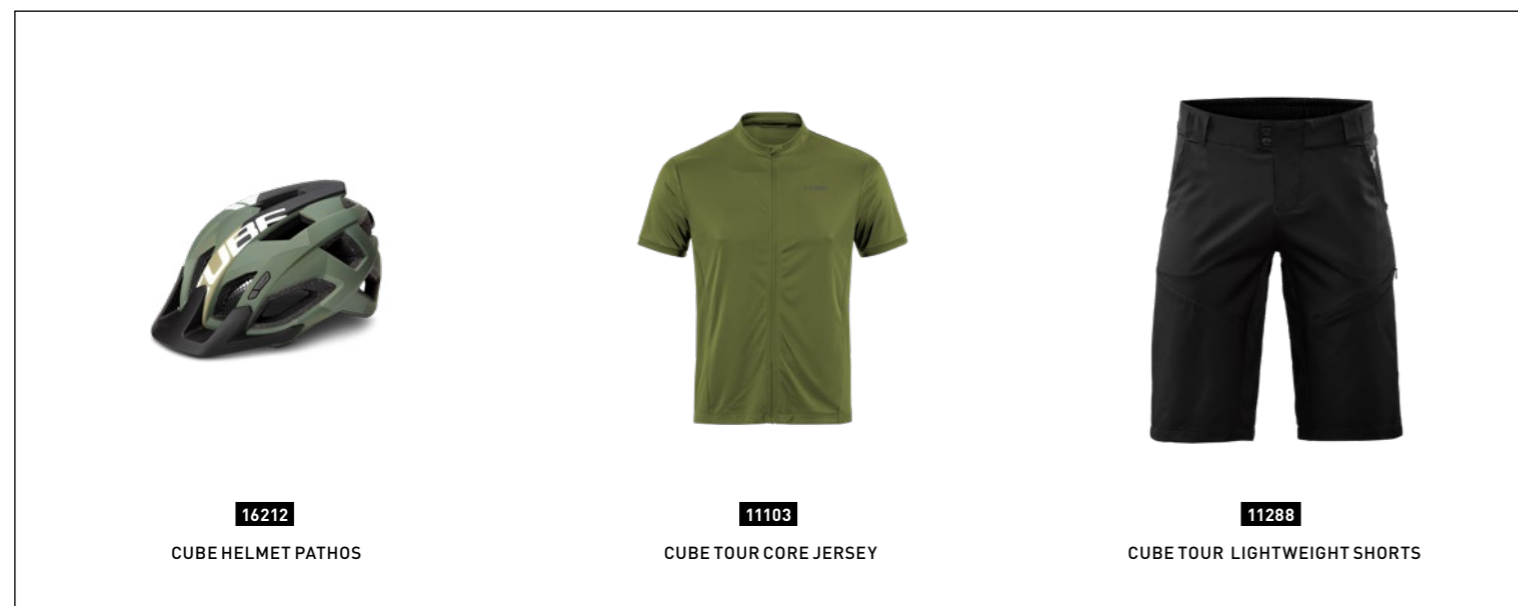
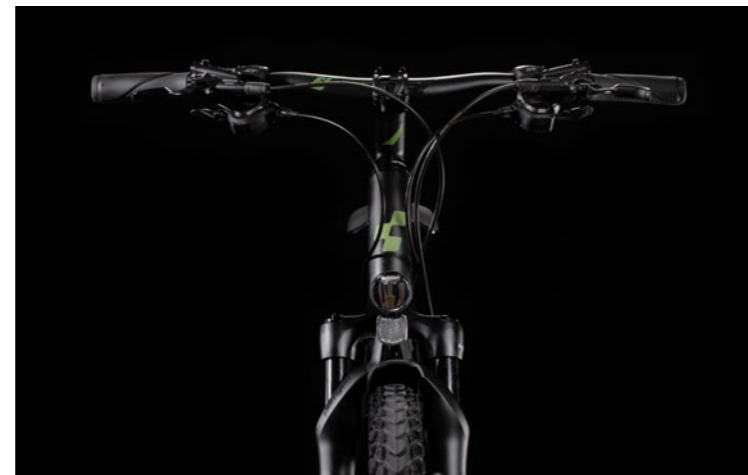



16212
CUBE HELMET PATHOS

11103
CUBE TOUR CORE JERSEY

11288
CUBE TOUR LIGHTWEIGHT SHORTS

What do you need in an adventure touring bike? We made our own list and built the Kathmandu SL around it: light, stiff, strong, versatile, reliable and, above all, comfortable. With the peerless performance of Shimano XT 3x10 gears and a RockShox Paragon Gold air suspension fork, it's quite possibly the ultimate grand tourer. The IC 2.0 luggage rack combines with our aluminium SuperLite frame to make a formidable load-carrying companion for any adventure, big or small. Double-butted tubing removes weight from areas where it's safe to do so, and adds material where it's needed for strength. Combined with our Efficient Comfort Geometry, the result is a sublimely smooth ride that'll have you eating up the miles and coming back for more. And the integrated design of our carrier isn't just elegant – it's also exceptionally strong, stiff and stable. Wear components can be easily replaced and it even features a built-in rear light. Full-length mudguards, a kickstand and powerful all-weather hydraulic disc brakes round out the Kathmandu SL. If there's a better way of seeing the world from a saddle, we've yet to find it...

-  **FRAME** Aluminium Superlite Trekking Comfort IC 2.0 Double Butted
- SIZE** Men: 46, 50, 54, 58, 62, Trapeze: 46, 50, 54
- FORK** RockShox Paragon Gold Air, 65mm, Lockout

-  **HEADSET** SA Orbit Z, Semi-Integrated, 1 1/8"
- STEM** CUBE Performance Stem Pro, 31.8mm
- HANDLEBAR** CUBE Rise Trail Bar, 680mm
- GRIPS** Natural Fit Comfort
- REAR DERAILLEUR** Shimano XT RD-T8000, 10-Speed
- SHIFTERS** Shimano XT SL-T8000
- FRONT DERAILLEUR** Shimano XT FD-T8000, Top Swing, 31.8mm Clamp
- BRAKE SYSTEM** Shimano XT BR-T8000, Hydr. Disc Brake [180/160]
- CRANKSET** Shimano XT FC-T8000, Hollowtech II, 48x36x26T, 175mm, Integrated BB, Chainguard
- CASSETTE** Shimano CS-M771, 11-34T
- CHAIN** Shimano CN-HG95
- RIMS** CUBE EX21, 32H, Disc, Tubeless Ready
- FRONT HUB** Shimano DH-UR700-3D, Hub Dynamo, QR, Centerlock
- REAR HUB** Shimano XT FH-M8000, QR, Centerlock
- TYRES** Schwalbe Marathon Mondial, Kevlar, 47-622
- PEDALS** Trekking Gummiert
- SADDLE** Natural Fit Sequence + Comfort
- SEAT POST** CUBE Performance Post, 27.2mm
- SEATCLAMP** CUBE Screwlock, 31.8mm
- FRONT LIGHT** Busch & Müller Lumotec IQ-XS N Plus
- REAR LIGHT** Herrmans H-Trace
- KICKSTAND** CUBEstand Pro, Adjustable
- MUDGUARDS** CID 53
- BELL** knog Oi
- CARRIER** CUBE Integrated Carrier 2.0, CUBE Adapter Compatible, SnapIt Compatible and Rail

 **WEIGHT** #4,7 kg

-  **SPARE PARTS#**
- 10148** CUBE Hanger #148 short version
- 10324** CUBE Headset Orbit Z
- 13548** Inner Tube 28" TREKKING AGV 40 mm

KATHMANDU EXC

348350 | Trapeze | grey'n'orange



KATHMANDU EXC

348350 | grey'n'orange

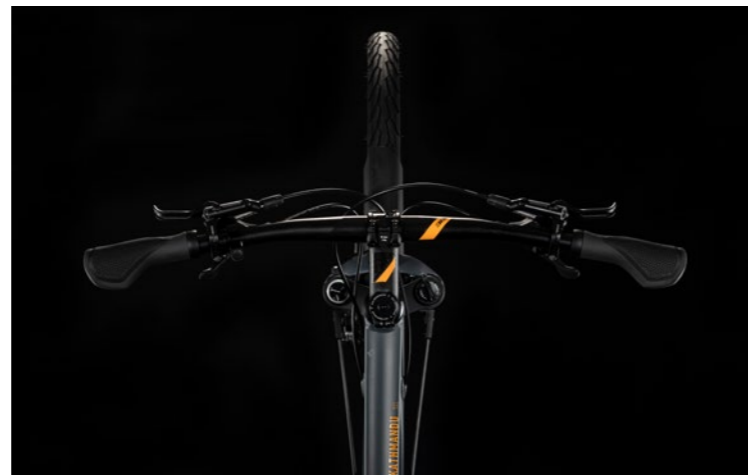

Whether you're heading to the ends of the earth or just to the edge of the map, you'll need a bike that you can rely on. The Kathmandu EXC with 3x10 Shimano gears will get you there – and back – in comfort and style, no matter how long your journey. Built with the reassurance of having passed our rigorous in-house lab testing with flying colours, you can be certain that it's tough enough to accompany you on your adventures for many years to come. Lightweight double-butted tubing saves weight where possible and maintains stiffness and strength where it's needed so that, combined with our Efficient Comfort Geometry, the Kathmandu EXC remains stable and predictable on any road, carrying any load. Our exclusive Integrated Carrier 2.0 is the strongest, stiffest possible platform for carrying your essential gear, with sleek lines to complement the frame's great looks and an integrated rear light. With the huge range of Shimano's legendary 3x10 transmission, you'll be able to make light work of any hill – and powerful hydraulic disc brakes will keep your speed in check on the way back down, too. The Suntour air suspension fork is adjustable for any rider or load, and takes the edge off even the most potholed and rutted of routes. Add the full-length mudguards, dynamo-powered light set and kickstand, and it's all you need for adventures both far and wide.

- FRAME** Aluminium Superlite Trekking Comfort IC 2.0 Double Butted
 - SIZE** Men: 46, 50, 54, 58, 62, Trapeze: 46, 50, 54
 - FORK** Suntour NCX D LO Air, 63mm
-
- HEADSET** SA Orbit Z, Semi-Integrated, 1 1/8"
 - STEM** CUBE Performance Stem Pro, 31.8mm
 - HANDLEBAR** CUBE Rise Trail Bar, 680mm
 - GRIPS** Natural Fit Comfort
 - REAR DERAILLEUR** Shimano XT RD-T8000, 10-Speed
 - SHIFTERS** Shimano Deore SL-M6000-I, Direct Attach, Rapidfire Plus
 - FRONT DERAILLEUR** Shimano XT FD-T8000, Top Swing, 31.8mm Clamp
 - BRAKE SYSTEM** Shimano BR-MT500, Hydr. Disc Brake (180/160)
 - CRANKSET** Shimano XT FC-T8000, Hollowtech II, 48x36x26T, 175mm, Integrated BB, Chainguard
 - CASSETTE** Shimano CS-HG500, 11-34T
 - CHAIN** MC X10
 - RIMS** CUBE EX21, 32H, Disc, Tubeless Ready
 - FRONT HUB** Shimano DH-3D72, Hub Dynamo, QR, Centerlock
 - REAR HUB** Shimano Deore FH-M6000, Centerlock
 - TYRES** Schwalbe Range Cruiser, Active, K-Guard, 47-622
 - PEDALS** Trekking Gummiert
 - SADDLE** Natural Fit Sequence + Comfort
 - SEAT POST** CUBE Performance Post, 27.2mm
 - SEATCLAMP** CUBE Screwlock, 31.8mm
 - FRONT LIGHT** Busch & Müller Lumotec IQ-XS N Plus
 - REAR LIGHT** Herrmans H-Trace
 - KICKSTAND** CUBEstand Pro, Adjustable
 - MUDGUARDS** A.C.I.D. 53
 - BELL** knog Oi
 - CARRIER** CUBE Integrated Carrier 2.0, CUBE Adapter Compatible, SnapIt Compatible and Rail

WEIGHT 5,4 kg

- SPARE PARTS**
- 10148** CUBE Hanger #148 short version
- 10324** CUBE Headset Orbit Z
- 13548** Inner Tube 28" TREKKING AGV 40 mm

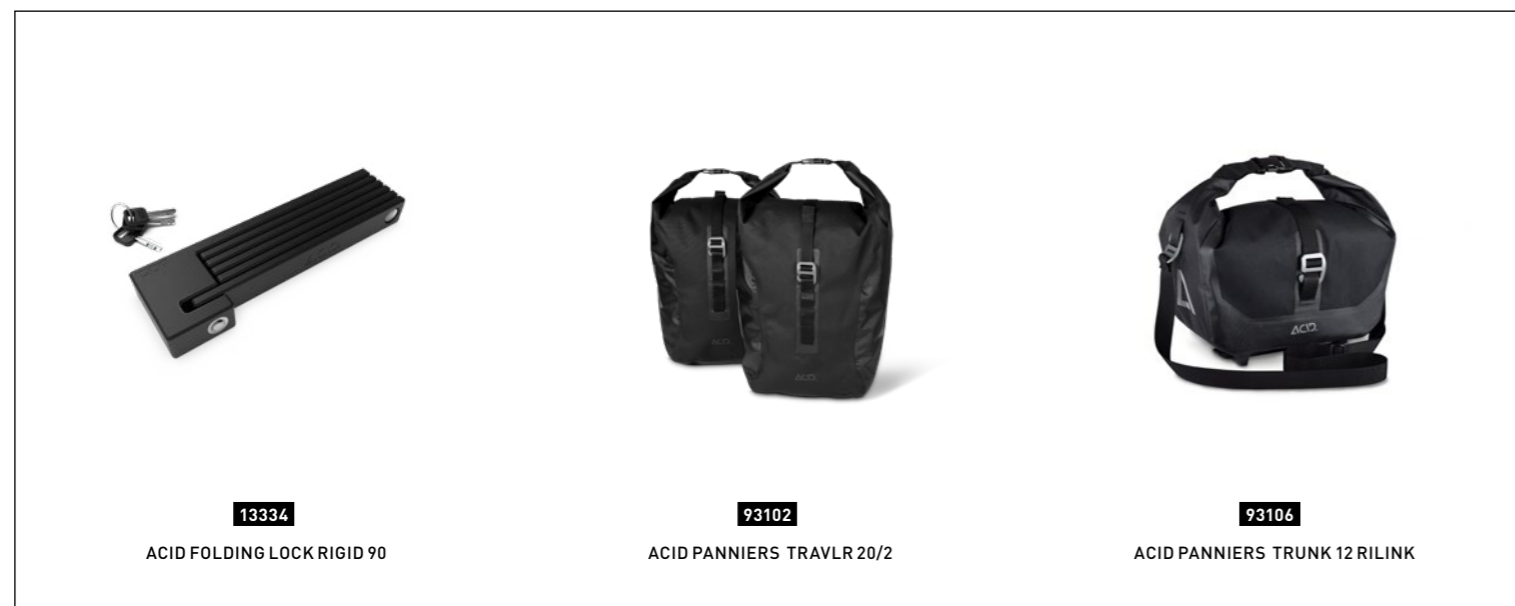

13334
ACID FOLDING LOCK RIGID 90

93102
ACID PANNIERS TRAVLR 20/2

93106
ACID PANNIERS TRUNK 12 RILINK

KATHMANDU PRO

348300 iridium'n'black



KATHMANDU PRO

348310 blue'n'orange



348300 | Trapeze iridium'n'black





348310 | Trapeze blue'n'orange



Many adventurers and travellers regard Kathmandu as the adventure capital of the world. It was certainly the inspiration for this bike. If you're heading out on your own adventure, you could do a lot worse than begin with our Kathmandu Pro. Designed with comfort, practicality and durability in mind, it's got everything you need to get you and your essential kit from A to B via C. The Integrated Carrier 2.0 luggage rack is a particularly neat feature. Elegantly incorporated into the frame design, it's one of the lightest and strongest carriers out there, with a seamlessly integrated rear light and easily replaceable wear components. Combined with the full-length mudguards, kickstand and hub dynamo-powered lighting system, it means you're all set for wherever adventure leads you. The easily adjustable Suntour air suspension fork takes the sting out of rough roads, smooth 3x10 Shimano Deore gears make light work of even the steepest of hills, and powerful hydraulic disc brakes ensure you're always in complete control. We've sweated all the details, so you don't have to. Because, after all, every adventure starts with a single pedal stroke...

-  **FRAME** Aluminium Superlite Trekking Comfort IC 2.0 Double Butted
- SIZE** Men: 46, 50, 54, 58, 62, Trapeze: 46, 50, 54
- FORK** Suntour NCX D LO Air, 63mm

-  **HEADSET** CUBE FPH863, Semi-Integrated
- STEM** CUBE Performance Stem Pro, 31.8mm
- HANDLEBAR** CUBE Rise Trail Bar, 680mm
- GRIPS** Natural Fit Comfort
- REAR DERAILLEUR** Shimano XT RD-T8000, 10-Speed
- SHIFTERS** Shimano Deore SL-M6000, Rapidfire-Plus
- FRONT DERAILLEUR** Shimano Deore FD-T6000, Top-Swing, 31.8mm
- BRAKE SYSTEM** Shimano BR-MT200, Hydr. Disc Brake (160/160)
- CRANKSET** Shimano FC-T551, Hollowtech II, 48x36x26T, 175mm, Integrated BB, Chainguard
- CASSETTE** Shimano CS-HG500, 11-34T
- CHAIN** MC X10
- RIMS** CUBE ZX20, 32H, Disc
- FRONT HUB** Shimano DH-3D37, Hub Dynamo, QR, Centerlock
- REAR HUB** Shimano Deore FH-M6000, Centerlock
- TYRES** Schwalbe Range Cruiser, Active, K-Guard, 47-622
- PEDALS** CUBE PP MTB
- SADDLE** Natural Fit Sequence + Comfort
- SEAT POST** CUBE Performance Post, 27.2mm
- SEATCLAMP** CUBE Screwlock, 31.8mm
- FRONT LIGHT** Busch&Müller Lumotec Avy T Senso Plus
- REAR LIGHT** Herrmans H-Trace
- KICKSTAND** CUBEstand Pro, Adjustable
- MUDGUARDS** CID 53
- BELL** Mini Bell
- CARRIER** CUBE Integrated Carrier 2.0, CUBE Adapter Compatible, SnapIt Compatible and Rail

 **WEIGHT** #5,8 kg

-  **SPARE PARTS**
- 10148** CUBE Hanger #148 short version
- 10324** CUBE Headset Orbit Z
- 13548** Inner Tube 28" TREKKING AGV 40 mm



93270

ACID PEDALS FLAT C1-1B HYBRID



13022

CUBE BOTTLE CAGE HPP



93122

ACID CARRIER BASKET 25 RILINK



TOURING EXC

348210 | Trapeze | red 'n' grey



TOURING EXC

348210 | red 'n' grey



348210 | Easy Entry | red 'n' grey



You might say we're biased, but we reckon the Touring EXC is the ideal all-rounder – perfect for longer rides at the weekend, daily use as a traffic-beating commuter or just as an excuse to get out in the fresh air and exercise. With a slick-shifting and ultra-reliable Shimano 3x10-speed transmission and powerful, all-weather hydraulic disc brakes, it's ideally equipped to help get you through the everyday – or escape it completely. The lightweight aluminium frame is a masterpiece of understated CUBE design, incorporating a plethora of neat design touches like internal cable routing for reduced maintenance, and hidden luggage carrier and mudguard mounting points. Available in Easy Entry, Trapeze and classic Men's configurations and a wide range of sizes, there'll be one that's the perfect fit for you. And, with the benefit of our Efficient Comfort Geometry, you know that every mile will be a pleasure, from the first to the last. We added a luggage carrier, full mudguards, a chain guard, kickstand and hub dynamo-powered lighting system so that you're fully equipped for any eventuality, and topped it all off with a Suntour suspension fork to help you take the rough with the smooth. Add it all up, and the Touring EXC is a versatile, reliable and – dare we say it – positively inspirational two-wheeled companion. Now go and explore...

FRAME Aluminium Superlite Trekking Comfort Double Butted
SIZE Men: 46, 50, 54, 58, 62, Easy Entry: 45, 49, 53, Trapeze: 46, 50, 54
FORK Suntour NEX HLO, 63mm

HEADSET CUBE FPH863, Semi-Integrated
STEM Satori Up2 Plus, 31.8mm, Adjustable
HANDLEBAR CUBE Rise Trail Bar, 680mm; EE: CUBE Comfort Shape Bar
GRIPS Natural Fit Comfort
REAR DERAILLEUR Shimano Deore RD-T6000, 10-Speed
SHIFTERS Shimano Deore SL-M6000, Rapidfire-Plus
FRONT DERAILLEUR Shimano Deore FD-T6000, Top-Swing, 31.8mm
BRAKE SYSTEM Shimano BR-MT200, Hydr. Disc Brake (160/160)
CRANKSET Shimano FC-T521, 48x36x26T, Octalink, BB-ES300, 175mm
CASSETTE Shimano CS-HG500, 11-34T
CHAIN MC X10
RIMS CUBE ZX20, 36H, Disc
FRONT HUB Shimano DH-3D37, Hub Dynamo, QR, Centerlock
REAR HUB Shimano FH-TX505, QR, Centerlock
TYRES Schwalbe Range Cruiser, Active, K-Guard, 47-622
PEDALS CUBE PP MTB
SADDLE Natural Fit Sequence Comfort
SEAT POST CUBE Performance Post, 27.2mm
SEATCLAMP CUBE Screwlock, 31.8mm
FRONT LIGHT AXA Compactline 20, AC
REAR LIGHT relock LS 613 Duo Flat
KICKSTAND CUBEstand Cmpt
MUDGUARDS CID 53
BELL Mini Bell
CARRIER CID Semi-Integrated Carrier, ACID RILink Adapter Compatible

WEIGHT 6,5 kg

SPARE PARTS#
10148 CUBE Hanger #148 short version
10324 CUBE Headset Orbit Z
13548 Inner Tube 28" TREKKING AGV 40 mm

TOURING EXC

348200 | Trapeze | iridium'n'silver



TOURING EXC

348200 | iridium'n'silver



348200 | Easy Entry | iridium'n'silver



You might say we're biased, but we reckon the Touring EXC is the ideal all-rounder – perfect for longer rides at the weekend, daily use as a traffic-beating commuter or just as an excuse to get out in the fresh air and exercise. With a slick-shifting and ultra-reliable Shimano 3x10-speed transmission and powerful, all-weather hydraulic disc brakes, it's ideally equipped to help get you through the everyday – or escape it completely. The lightweight aluminium frame is a masterpiece of understated CUBE design, incorporating a plethora of neat design touches like internal cable routing for reduced maintenance, and hidden luggage carrier and mudguard mounting points. Available in Easy Entry, Trapeze and classic Men's configurations and a wide range of sizes, there'll be one that's the perfect fit for you. And, with the benefit of our Efficient Comfort Geometry, you know that every mile will be a pleasure, from the first to the last. We added a luggage carrier, full mudguards, a chain guard, kickstand and hub dynamo-powered lighting system so that you're fully equipped for any eventuality, and topped it all off with a Suntour suspension fork to help you take the rough with the smooth. Add it all up, and the Touring EXC is a versatile, reliable and – dare we say it – positively inspirational two-wheeled companion. Now go and explore...

FRAME Aluminium Superlite Trekking Comfort Double Butted
SIZE Men: 46, 50, 54, 58, 62, Easy Entry 45, 49, 53, Trapeze: 46, 50, 54
FORK Suntour NEX HLO, 63mm

HEADSET CUBE FPH863, Semi-Integrated
STEM Satori Up2 Plus, 31.8mm, Adjustable
HANDLEBAR CUBE Rise Trail Bar, 680mm; EE: CUBE Comfort Shape Bar
GRIPS Natural Fit Comfort
REAR DERAILLEUR Shimano Deore RD-T6000, 10-Speed
SHIFTERS Shimano Deore SL-M6000, Rapidfire-Plus
FRONT DERAILLEUR Shimano Deore FD-T6000, Top-Swing, 31.8mm
BRAKE SYSTEM Shimano BR-MT200, Hydr. Disc Brake (160/160)
CRANKSET Shimano FC-T521, 48x36x26T, Octalink, BB-ES300, 175mm
CASSETTE Shimano CS-HG500, 11-34T
CHAIN MC X10
RIMS CUBE ZX20, 36H, Disc
FRONT HUB Shimano DH-3D37, Hub Dynamo, QR, Centerlock
REAR HUB Shimano FH-TX505, QR, Centerlock
TYRES Schwalbe Range Cruiser, Active, K-Guard, 47-622
PEDALS CUBE PP MTB
SADDLE Natural Fit Sequence Comfort
SEAT POST CUBE Performance Post, 27.2mm
SEATCLAMP CUBE Screwlock, 31.8mm
FRONT LIGHT AXA Compactline 20, AC
REAR LIGHT relock LS 613 Duo Flat
KICKSTAND CUBEstand Cmpt
MUDGUARDS ACID 53
BELL Mini Bell
CARRIER ACID Semi-Integrated Carrier, ACID RILink Adapter Compatible

WEIGHT 6,5 kg

SPARE PARTS
13548 Inner Tube 28" TREKKING AGV 40 mm
10148 CUBE Hanger #148 short version
10324 CUBE Headset Orbit Z

TOURING PRO

348150 | Trapeze | grey'n'orange



TOURING PRO

348150 | Trapeze | grey'n'orange



348150 | Easy Entry | grey'n'orange



The CUBE Touring Pro has two standout features. First, of course, there's its high-quality aluminium frame. Light, comfortable and efficient whether you're riding across town or heading out in search of new routes at the weekend, it'll win you over from the first turn of the pedals. Second, there's its powerful hydraulic disc brake system. Why did we select disc brakes for our versatile tourer? Simple: because they slow you down safely and reliably, whatever the weather's doing. And that's an important consideration, whether you're an everyday rider braving the traffic on the way to work or an occasional tourer exploring at the weekends. The three frame configurations ensure the perfect fit for every rider, and with the kind of attention to detail you'd expect from CUBE – like hidden rack and mudguard fixings and internally routed cables – you'll be amazed at its elegant looks. Combined with the reliable Shimano 24-speed transmission, a full complement of mudguards, rear luggage carrier and a built-in lighting system, it's the perfect companion for many, many miles of riding pleasure.

FRAME Aluminium Superlite Trekking Comfort Double Butted
SIZE Men: 46, 50, 54, 58, 62, Easy Entry: 45, 49, 53, Trapeze: 46, 50, 54
FORK R Suntour NEX HLO, 63mm

HEADSET CUBE FPH863, Semi-Integrated
STEM Satori Up2 Plus, 31.8mm, Adjustable
HANDLEBAR CUBE Rise Trail Bar, 680mm; EE: CUBE Comfort Shape Bar
GRIPS Natural Fit Comfort
REAR DERAILLEUR Shimano RD-M360, 8-Speed
SHIFTERS Shimano SL-M315, Rapidfire Plus
FRONT DERAILLEUR Shimano FD-M310, Topswing, 31.8mm
BRAKE SYSTEM Shimano BR-MT200, Hydr. Disc Brake (160/160)
CRANKSET Shimano FC-T801, 48x36x26T, 175mm
CASSETTE Shimano CS-HG200, 12-32T
CHAIN MC Z51
RIMS CUBE ZX20, 36H, Disc
FRONT HUB Shimano DH-3D37, Hub Dynamo, QR, Centerlock
REAR HUB Shimano FH-TX505, QR, Centerlock
TYRES Schwalbe Range Cruiser, Active, K-Guard, 47-622
PEDALS CUBE PP MTB
SADDLE Natural Fit Sequence Comfort
SEAT POST CUBE Performance Post, 27.2mm
SEATCLAMP CUBE Screwlock, 31.8mm
FRONT LIGHT AXA Compactline 20, AC
REAR LIGHT Trelock LS 613 Duo Flat
KICKSTAND CUBEstand Cmpt
MUDGUARDS ACID 53
BELL Mini Bell
CARRIER ACID Semi-Integrated Carrier, ACID RILink Adapter Compatible

WEIGHT 6,9 kg

SPARE PARTS#
10148 CUBE Hanger #148 short version
10324 CUBE Headset Orbit Z
13548 Inner Tube 28" TREKKING AGV 40 mm

TOURING

348110 | Trapeze | green 'n' white



TOURING

348110 | green 'n' white



348110 | Easy Entry | green 'n' white



When the open road beckons, you'll need a bike that's comfortable, versatile, safe and fun to ride. The CUBE Touring ticks all the boxes, combining a lightweight aluminium frame with all the features you need to enjoy your cycling. And, because it's available in three different frame configurations – Easy Entry, Trapeze, and classic Men's – there's one to suit every rider. Our Efficient Comfort Geometry ensures that you'll be comfortable and in full control, even on the longest rides, and you can rest assured that our in-house test lab has verified the strength, durability and safety of the frame and all the components. Finishing touches like internally routed cables and ultra-neat rack and mudguard mounting points demonstrate the attention to detail that goes into every CUBE frame. Slick-shifting Shimano gears, easy-to-use rim brakes and a comfort-enhancing suspension fork all add to the appeal, while a full complement of essential accessories means that your CUBE Touring is ready to take on any journey. The only remaining question is, where will it take you tomorrow?

FRAME# Aluminium Superlite Trekking Comfort Double Butted
SIZE# Men: 46, 50, 54, 58, 62, Easy Entry: 45, 49, 53, Trapeze: 46, 50, 54
FORK# R Suntour NEX, 63mm; EE: 50mm

HEADSET# CUBE FPH863, Semi-Integrated
STEM# IL Adjustable, 31.8mm
HANDLEBAR# CUBE Rise Trail Bar, 680mm; EE: CUBE Comfort Shape Bar
GRIPS# CUBE Performance Grip
REAR DERAILLEUR# Shimano RD-M310, 8-Speed
SHIFTERS# Shimano ST-TX800
FRONT DERAILLEUR# Shimano FD-M310, Topswing, 31.8mm
BRAKE SYSTEM# - Brake
CRANKSET# Shimano FC-TX801, 48x38x28T, BB-UN100, 175mm
CASSETTE# Shimano CS-HG200, 12-32T
CHAIN# MC Z72
RIMS# CUBE SX24, 36H, V-Brake
FRONT HUB# Shimano DH-C3000, Hub Dynamo, Nut
REAR HUB# Shimano FH-TX800, Nut
TYRES# CUBE Impac Streetpac, 42-622
PEDALS# CUBE PP Trekking
SADDLE# Natural Fit Sequence Comfort
SEAT POST# CUBE Performance Post, 27.2mm
SEATCLAMP# CUBE Screwlock, 31.8mm
FRONT LIGHT# ED 15 Lux
REAR LIGHT# ED Steady Light
KICKSTAND# CUBEstand Cmpt
MUDGUARDS# CUBE Black Shiny
BELL# humpert
CARRIER# ACID Semi-Integrated Carrier, ACID RILink Adapter Compatible

WEIGHT# 6,3 kg

SPARE PARTS#
10148 CUBE Hanger #148 short version
10324 CUBE Headset Orbit Z
13548 Inner Tube 28" TREKKING AGV 40 mm

TOURING

348100 | Trapeze | black 'n' blue



TOURING

348100 | black 'n' blue



348100 | Easy Entry | black 'n' blue



When the open road beckons, you'll need a bike that's comfortable, versatile, safe and fun to ride. The CUBE Touring ticks all the boxes, combining a lightweight aluminium frame with all the features you need to enjoy your cycling. And, because it's available in three different frame configurations – Easy Entry, Trapeze, and classic Men's – there's one to suit every rider. Our Efficient Comfort Geometry ensures that you'll be comfortable and in full control, even on the longest rides, and you can rest assured that our in-house test lab has verified the strength, durability and safety of the frame and all the components. Finishing touches like internally routed cables and ultra-neat rack and mudguard mounting points demonstrate the attention to detail that goes into every CUBE frame. Slick-shifting Shimano gears, easy-to-use rim brakes and a comfort-enhancing suspension fork all add to the appeal, while a full complement of essential accessories means that your CUBE Touring is ready to take on any journey. The only remaining question is, where will it take you tomorrow?

FRAME# Aluminium Superlite Trekking Comfort Double Butted
SIZE# Men: 46, 50, 54, 58, 62, Easy Entry: 45, 49, 53, Trapeze: 46, 50, 54
FORK# R Suntour NEX, 63mm; EE: 50mm

HEADSET# CUBE FPH863, Semi-Integrated
STEM# IL Adjustable, 31.8mm
HANDLEBAR# CUBE Rise Trail Bar, 680mm; EE: CUBE Comfort Shape Bar
GRIPS# CUBE Performance Grip
REAR DERAILLEUR# Shimano RD-M310, 8-Speed
SHIFTERS# Shimano ST-TX800
FRONT DERAILLEUR# Shimano FD-M310, Topswing, 31.8mm
BRAKE SYSTEM# -Brake
CRANKSET# Shimano FC-TX801, 48x38x28T, BB-UN100, 175mm
CASSETTE# Shimano CS-HG200, 12-32T
CHAIN# MC Z72
RIMS# CUBE SX24, 36H, V-Brake
FRONT HUB# Shimano DH-C3000, Hub Dynamo, Nut
REAR HUB# Shimano FH-TX800, Nut
TYRES# CUBE Impac Streetpac, 42-622
PEDALS# CUBE PP Trekking
SADDLE# Natural Fit Sequence Comfort
SEAT POST# CUBE Performance Post, 27.2mm
SEATCLAMP# CUBE Screwlock, 31.8mm
FRONT LIGHT# ED 15 Lux
REAR LIGHT# ED Steady Light
KICKSTAND# CUBEstand Cmpt
MUDGUARDS# CUBE Black Shiny
BELL# lumpert
CARRIER# ACID Semi-Integrated Carrier, ACID RILink Adapter Compatible

WEIGHT# 6,3 kg

SPARE PARTS#
10148 CUBE Hanger #148 short version
10324 CUBE Headset Orbit Z
13548 Inner Tube 28" TREKKING AGV 40 mm

TOURING ONE

348050 | Trapeze | iridium'n'red



TOURING ONE

348050 | iridium'n'red



Not available in all markets.

348050 | Easy Entry | iridium'n'red



FOR us #Discoverers

Simplicity can be a virtue, but we never forget that detail matters. That's why the aluminium Superlite frame of the Travel is double butted, saving weight where possible but adding extra material where it's needed for strength. Combined with our rigorous in-house testing procedures, it's your guarantee of long-lasting durability and superb ride quality. We built in enough clearance to run 28in tyres up to 47mm wide, giving loads of choice for added comfort and puncture resistance. Full lowrider rack compatibility means that the rigid aluminium fork is both accurate and extremely versatile, and we routed cables inside the down tube to match the frame's Smooth Welding-enhanced clean looks and reduce maintenance requirements. With double bottle cage mounts and a rear dropout that neatly accommodates a kickstand, the only thing left is to decide where your curiosity is going to take you...



TRAVEL SL

350600 | Trapeze | iridium 'n' silver



TRAVEL SL

350600 | iridium 'n' silver



What would your ideal all-round touring bike look like? We reckon it'd look a lot like the Travel SL. Tasked with designing the ultimate low-maintenance, go-anywhere tourer, our engineers came up trumps with this belt-driven, hub-g geared beauty. Shimano's smooth-shifting, wide-ranging Alfine 11-speed gears give you the range you need to tackle any hill with ease, while Gates' ultra-durable and practically silent CDX belt drive makes oily chains and rattling gears a thing of the past. Double-butted frame tubes give a supple ride quality, low weight and exceptional strength, backed up by the reassurance of comprehensive testing in our own 24/7 safety lab. The light, accurate rigid fork is fully compatible with lowrider racks, while the semi-integrated rear rack is a masterpiece of minimalist, functional design. Wide tyre clearances and a full complement of touring accessories are the icing on the cake. The Travel SL is ready to go anywhere. So... where would you like to go today?

- FRAME** Aluminium Superlite Urban Double Butted
- SIZE** Men: 46, 50, 54, 58, 62, Trapeze: 46, 50, 54
- FORK** Aluminium Rigid Fork

- HEADSET** SA Orbit Z, Semi-Integrated 1 1/8"
- STEM** CUBE Performance Stem Pro, 31.8mm
- HANDLEBAR** CUBE Rise Trail Bar, 680mm
- GRIPS** Brooks Cambium
- SHIFTERS** Shimano Alfine SL-S700
- BRAKE SYSTEM** Shimano XT BR-T8000, Hydr. Disc Brake (160/160)
- CRANKSET** Gates CDX Center Track, 46T, BB Gates
- SPROCKET** Gates CDX Center Track, 22T
- CHAIN** Gates CDX, 113T
- FRONT HUB** Shimano DH-UR700-3D, Hub Dynamo, QR, Centerlock
- REAR HUB** Shimano Alfine SG-S7001, 11-Speed
- TYRES** Schwabe Marathon Mondial, Kevlar, 37-622
- PEDALS** P 615M
- SADDLE** Brooks C15 Cambium
- SEAT POST** CUBE Performance Post, 27.2mm
- SEATCLAMP** CUBE Screwlock, 31.8mm
- FRONT LIGHT** Busch & Müller Lumotec IQ-XS N Plus
- REAR LIGHT** Busch & Müller Toplight 2C
- KICKSTAND** CUBEstand Pro, Adjustable
- MUDGUARDS** ACID 45
- BELL** nog Oi
- CARRIER** ACID Semi-Integrated Carrier, ACID RiLink Adapter Compatible

- WEIGHT** 3,6 kg

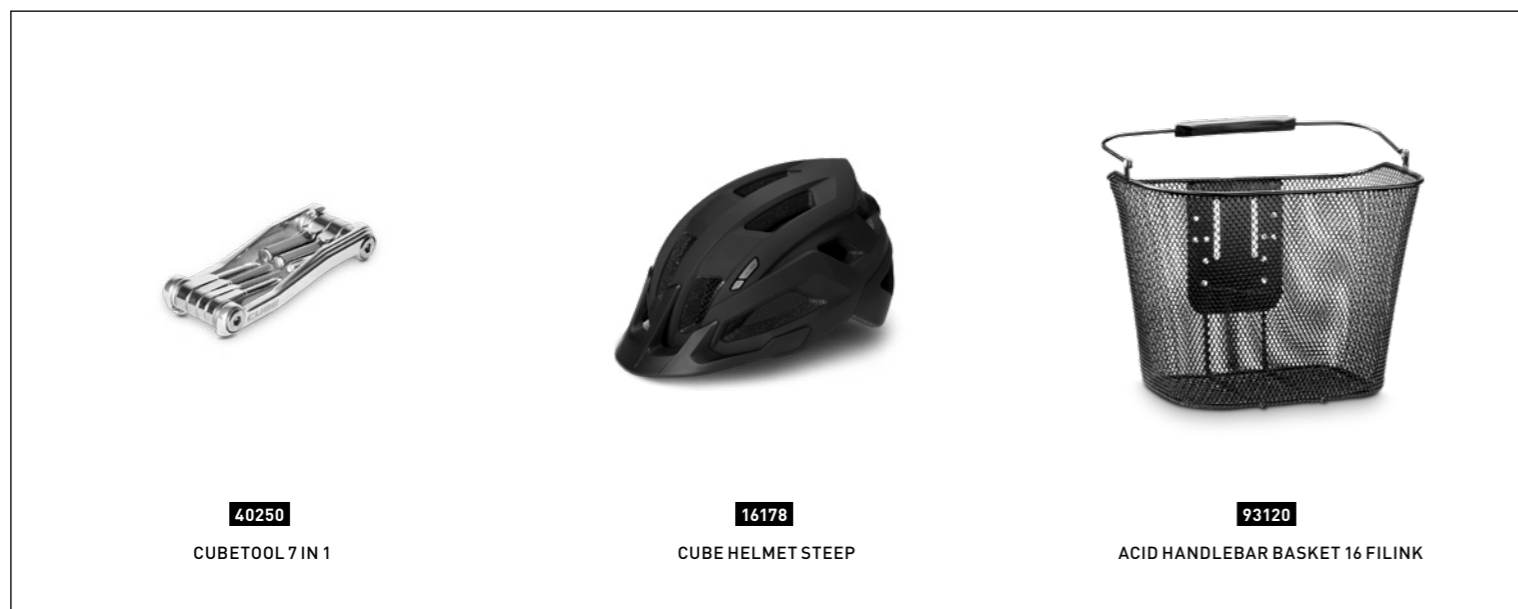

- SPARE PARTS**
- 10324** CUBE Headset Orbit Z
- 13550** Inner Tube 28" TREKKING SV 40 mm

TOUR

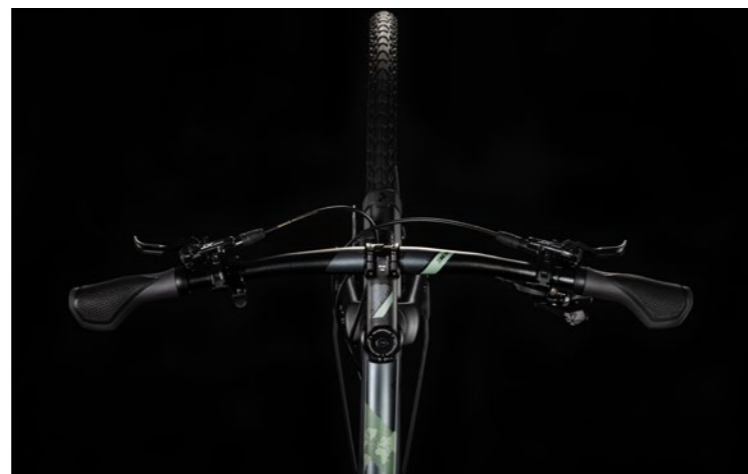

Whether your ambitions extend to crossing continents or just getting across town, the Travel Sport's combination of low weight and reliable, high-end components will get you there in comfort and style. Boasting the huge gear range and proven reliability of Sram's 1x12 Eagle transmission, there's no mountain pass too steep for the Travel Sport. Clearance for grippy, comfortable tyres and the addition of powerful hydraulic disc brakes means you'll always be in full control, too. The lightweight, double-butted frame combines exceptional strength and durability with a comfortable ride and intuitive handling, and the light rigid fork boasts full lowrider rack compatibility to complement the included rear luggage carrier. Dual bottle cage bosses, full-length mudguards, a light set and kickstand round off the equipment package. There's nothing more to add, except to point out that the Travel Sport is a true thoroughbred amongst touring bikes.

- FRAME#** Aluminium Superlite Crossroad Taper Double Butted
- SIZE#** Men: 50, 53, 56, 59, 62, Trapeze: 47, 50, 53
- FORK#** Aluminium Rigid Fork

- HEADSET#** SA Orbit Z-t, Top Zero-Stack 1 1/8" (OD44mm), Bottom Integrated 1 1/2"
- STEM#** CUBE Performance Stem Pro, 31.8mm
- HANDLEBAR#** CUBE Rise Trail Bar, 680mm
- GRIPS#** Natural Fit Comfort
- REAR DERAILLEUR#** Sram GX Eagle™, 12-Speed
- SHIFTERS#** Sram GX Eagle™ Trigger
- BRAKE SYSTEM#** Shimano XT BR-M8100, Hydr. Disc Brake (160/160)
- CRANKSET#** Sram Force Carbon D1 DUB, 38T, 175mm
- CASSETTE#** Sram XG-1230, 11-50T
- CHAIN#** Sram SX Eagle™
- RIMS#** CUBE EX21, 32H, Disc, Tubeless Ready
- FRONT HUB#** Shimano Alfine DH-S501, Hub Dynamo, QR
- REAR HUB#** Shimano Deore FH-M6000, Centerlock
- TYRES#** Schwalbe Marathon Mondial, Kevlar, 37-622
- PEDALS#** CUBE PP MTB
- SADDLE#** Natural Fit Sequence+
- SEAT POST#** CUBE Performance Post, 27.2mm
- SEATCLAMP#** CUBE Screwlock, 31.8mm
- FRONT LIGHT#** Busch&Müller Lumotec IQ-XS N Plus
- REAR LIGHT#** Busch&Müller Toplight 2C
- KICKSTAND#** CUBEstand Pro, Adjustable
- MUDGUARDS#** A:CID 45
- BELL#** Knog Oi
- CARRIER#** Standwell Bag Carrier Small

WEIGHT# 2,5 kg

- SPARE PARTS#**
- 10148** CUBE Hanger #148 short version
- 10325** CUBE Headset Orbit Z-t + 1 1/8 crown race
- 13550** Inner Tube 28" TREKKING SV 40 mm

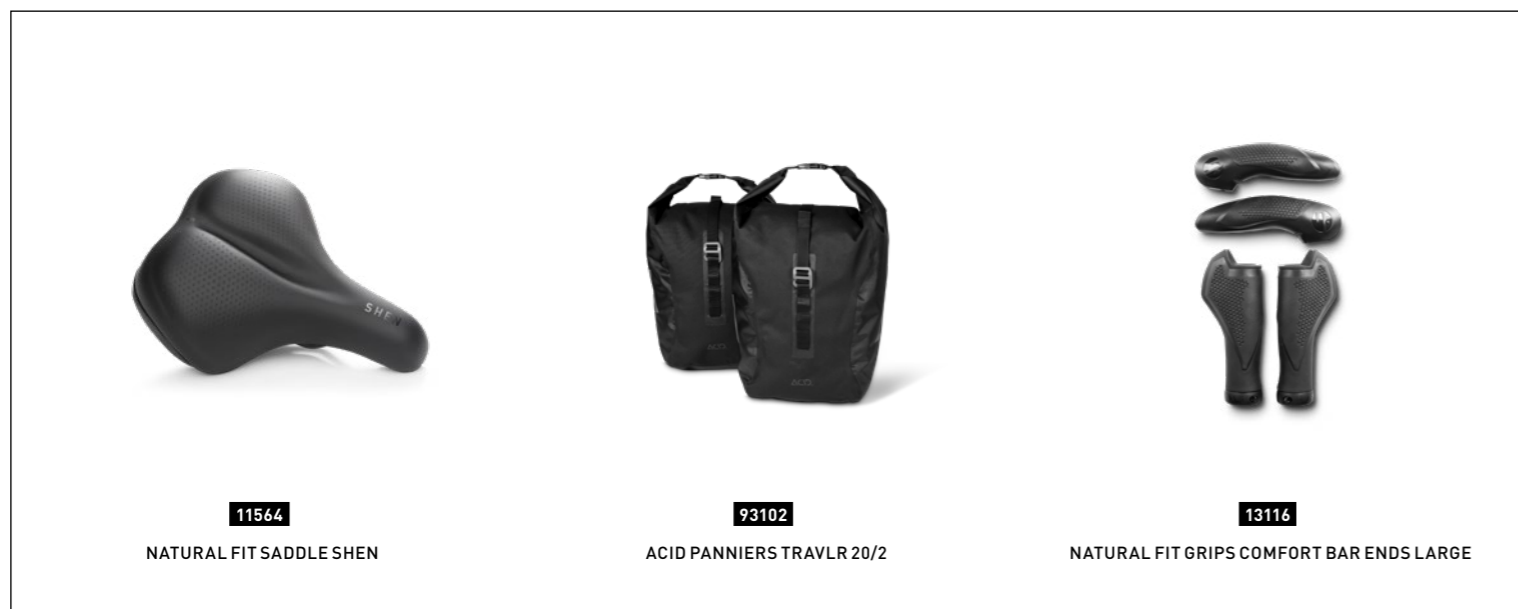

11564
NATURAL FIT SADDLE SHEN

93102
ACID PANNIERS TRAVLR 20/2

13116
NATURAL FIT GRIPS COMFORT BAR ENDS LARGE



Don't be deceived by its deliberately understated looks – the Travel EXC is no ordinary sports tourer. A lightweight machine built around Shimano's low-maintenance 8-speed Alfine hub gear and Gates' durable belt drive, it consigns rattling gears, oily chains and the chore of regular maintenance to the past. The classically elegant frame design features double-butted aluminium tubing for the best combination of low weight, high strength and great ride quality. We've built in enough clearance for tyres up to 47x622, giving access to a wide range of options suitable for the toughest of touring routes. Wherever you're headed and whatever load you're carrying, the low maintenance drive belt and smooth simplicity of the hub gears mean you can concentrate on the adventure, and stop worrying about the bike. With powerful hydraulic disc brakes, a lightweight and strong rigid fork with lowrider rack compatibility and a full complement of touring gear – including kickstand, lights and mudguards – it's the ideal lightweight, round-the-world companion.

-  **FRAME** #Aluminium Superlite Urban Double Butted
- SIZE** #Men: 46, 50, 54, 58, 62, Trapeze: 46, 50, 54
- FORK** #Aluminium Rigid Fork

-  **HEADSET** #SA Orbit Z, Semi-Integrated 1 1/8"
- STEM** #CUBE Performance Stem Pro, 31.8mm
- HANDLEBAR** #CUBE Rise Trail Bar, 680mm
- GRIPS** #Natural Fit Comfort
- SHIFTERS** #Shimano Alfine SL-S7000
- BRAKE SYSTEM** #Shimano BR-MT200, Hydr. Disc Brake (160/160)
- CRANKSET** #Gates S150 CDN, 46T, 170mm, BB Thun Zumba
- CASSETTE** #Gates Rear Sprocket CDN, 22T
- CHAIN** #Gates CDN, 113T
- RIMS** #CUBE EX21, 32H, Disc, Tubeless Ready
- FRONT HUB** #Shimano DH-3D37, Hub Dynamo, QR, Centerlock
- REAR HUB** #Shimano Alfine SG-S700, 8-Speed
- TYRES** #Schwalbe Marathon Mondial, Kevlar, 37-622
- PEDALS** #P 615M
- SADDLE** #Natural Fit Sequence+
- SEAT POST** #CUBE Performance Post, 27.2mm
- SEATCLAMP** #CUBE Screwlock, 31.8mm
- FRONT LIGHT** #Busch&Müller Lumotec IQ-XS N Plus
- REAR LIGHT** #Busch&Müller Toplight 2C
- KICKSTAND** #CUBEstand Pro, Adjustable
- MUDGUARDS** #ACID 45
- BELL** #knog Oi
- CARRIER** #ACID Semi-Integrated Carrier, ACID RiLink Adapter Compatible

 **WEIGHT** #3,9 kg

-  **SPARE PARTS** #
- 10324** CUBE Headset Orbit Z
- 13548** Inner Tube 28" TREKKING AGV 40 mm



11438
SQUARE JERSEY SPORT



11960
CUBE GLOVES XNF



16284
CUBE HELMET CINITY



At CUBE we believe that practical, durable bikes should also be fun. The Travel Pro takes all the functionality, comfort and practicality of our Travel series and adds an 8-speed hub gear and practical low maintenance belt drive for the ultimate in hassle-free cycling. No more oily chain, no more fiddly gear adjustment, no more worries! You can just enjoy the ride – and who wouldn't want that? The 29er-inspired frame is built from light, strong and durable double-butted tubing, using our Smooth Welding technology at the seat and head tube junctions for a tidy, organic appearance. The semi-integrated luggage carrier complements the frame's sleek looks and provides strong, stable support for whatever load you want to bring along with you. Taking our cue from our hardtail mountain bikes, we included plenty of clearance for extra-wide tyres – so you've got more grip, comfort and control, even on rough roads. Throw in the powerful hydraulic disc brakes, full-length mudguards, light set and kickstand, and it adds up to an adaptable, rugged and hassle-free riding partner... wherever your explorations take you.

FRAME Aluminium Superlite Trekking Sport 29 Taper Double Butted
SIZE Men: 46, 50, 54, 58, 62, Trapeze: 46, 50, 54
FORK Aluminium Rigid Fork 29" Tapered

HEADSET CUBE H868P, Semi-Integrated
STEM CUBE Performance Stem Pro, 31.8mm
HANDLEBAR CUBE Rise Trail Bar, 680mm
GRIPS Natural Fit Comfort
SHIFTERS Shimano Alfine SL-S503
BRAKE SYSTEM Shimano BR-MT200, Hydr. Disc Brake (160/160)
CRANKSET Gates S150 CDN, 46T, 170mm, BB Thun Zumba
CASSETTE Gates Rear Sprocket CDN, 22T
CHAIN Gates CDN, 120T
RIMS CUBE EX21, 32H, Disc, Tubeless Ready
FRONT HUB Shimano DH-3D37, Hub Dynamo, QR, Centerlock
REAR HUB Shimano Nexus SG-C6001-8D, 8-Speed
TYRES Schwalbe Marathon Almotion, Performance, Kevlar, 55-622
PEDALS CUBE PP MTB
SADDLE Natural Fit Sequence Man
SEAT POST CUBE Performance Post, 27.2mm
SEATCLAMP CUBE Screwlock, 31.8mm
FRONT LIGHT AXA Compactline 20, AC
REAR LIGHT relock LS 613 Duo Flat
KICKSTAND CUBEstand Pro, Adjustable
MUDGUARDS CID 65
BELL knog Oi
CARRIER CID Semi-Integrated Carrier, CID RILink Adapter Compatible

WEIGHT 5,3 kg

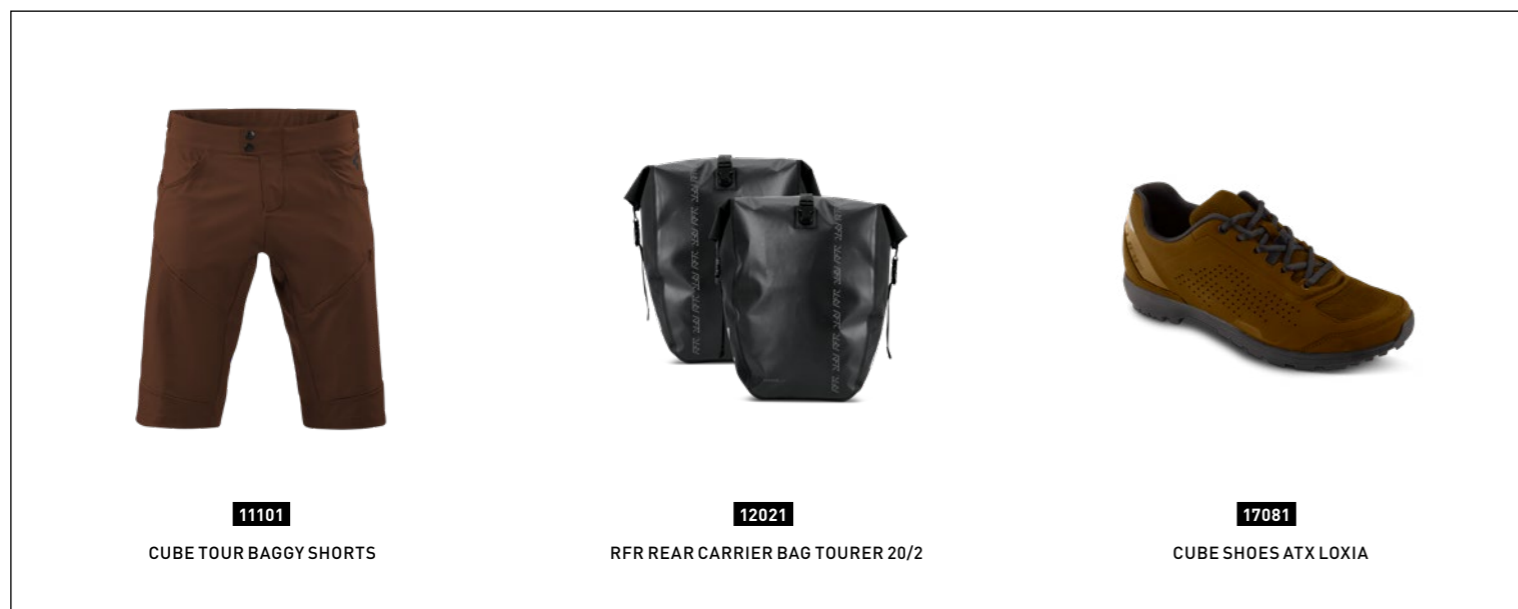

11101
CUBE TOUR BAGGY SHORTS

12021
RFR REAR CARRIER BAG TOURER 20/2

17081
CUBE SHOES ATX LOXIA

SPARE PARTS
10325 CUBE Headset Orbit Z-t + 1 1/8 crown race
13543 Inner Tube 27,5"/29" MTB AGV 40 mm



When you buy the CUBE Travel, the adventure comes free with the bike. By combining a lightweight, comfortable frame based around 29er wheels with a semi-integrated luggage carrier for neater looks and more secure load carrying, we've created a consummate all-rounder. Double-butted aluminium tubes combine strength and rigidity with low weight for the optimal blend of stiffness, durability and comfort and the rigid fork is light, accurate and robust. Whatever the scale of your adventure – from a trip to the coffee shop to a longer route out into the hills at the weekend – it's the perfect companion. There's loads of clearance for wide, grippy and comfortable tyres, while the full-length mudguards help keep you cleaner and drier even in bad weather. Shimano's 3x9-speed gears and powerful hydraulic disc brakes are smooth and reliable, and a full complement of accessories – including lights and kickstand – means you're all set for comfortable two-wheeled exploration. You can look at it this way: the Travel is your gateway to cycling freedom. Where will it take you?

FRAME Aluminium Superlite Trekking Sport 29 Taper Double Butted
SIZE Men: 46, 50, 54, 58, 62, Trapeze: 46, 50, 54
FORK Aluminium Rigid Fork 29" Tapered

HEADSET CUBE H868P, Semi-Integrated
STEM CUBE Performance Stem Pro, 31.8mm
HANDLEBAR CUBE Rise Trail Bar, 680mm
GRIPS Natural Fit Comfort
REAR DERAILLEUR Shimano Deore RD-M592, 9-Speed
SHIFTERS Shimano SL-M2010, Rapidfire-Plus
FRONT DERAILLEUR Shimano FD-M370, Topswing, 31.8mm
BRAKE SYSTEM Shimano BR-MT200, Hydr. Disc Brake (160/160)
CRANKSET Shimano FC-T3010, 48x36x26T, 175mm, BB-UN100, Chainguard
CASSETTE Shimano CS-HG200, 11-34T
CHAIN MC X9
RIMS CUBE EX21, 32H, Disc, Tubeless Ready
FRONT HUB Shimano DH-3D37, Hub Dynamo, QR, Centerlock
REAR HUB Shimano FH-TX505, QR, Centerlock
TYRES Schwalbe Marathon Almotion, Performance, Kevlar, 55-622
PEDALS CUBE PP MTB
SADDLE Natural Fit Sequence
SEAT POST CUBE Performance Post, 27.2mm
SEATCLAMP CUBE Screwlock, 31.8mm
FRONT LIGHT AXA Compactline 20, AC
REAR LIGHT relock LS 613 Duo Flat
KICKSTAND CUBEstand Cmpt
MUDGUARDS ACID 65
BELL Mini Bell
CARRIER ACID Semi-Integrated Carrier, ACID RILink Adapter Compatible

WEIGHT #5,2 kg

SPARE PARTS
10148 CUBE Hanger #148 short version
10325 CUBE Headset Orbit Z-t + 1 1/8 crown race
13543 Inner Tube 27,5"/29" MTB AGV 40 mm



13330
ACID CHAIN LOCK CORVID K120



16175
CUBE HELMET PATHOS



10577
CUBE CLASSIC MERINO JERSEY

U R B A N

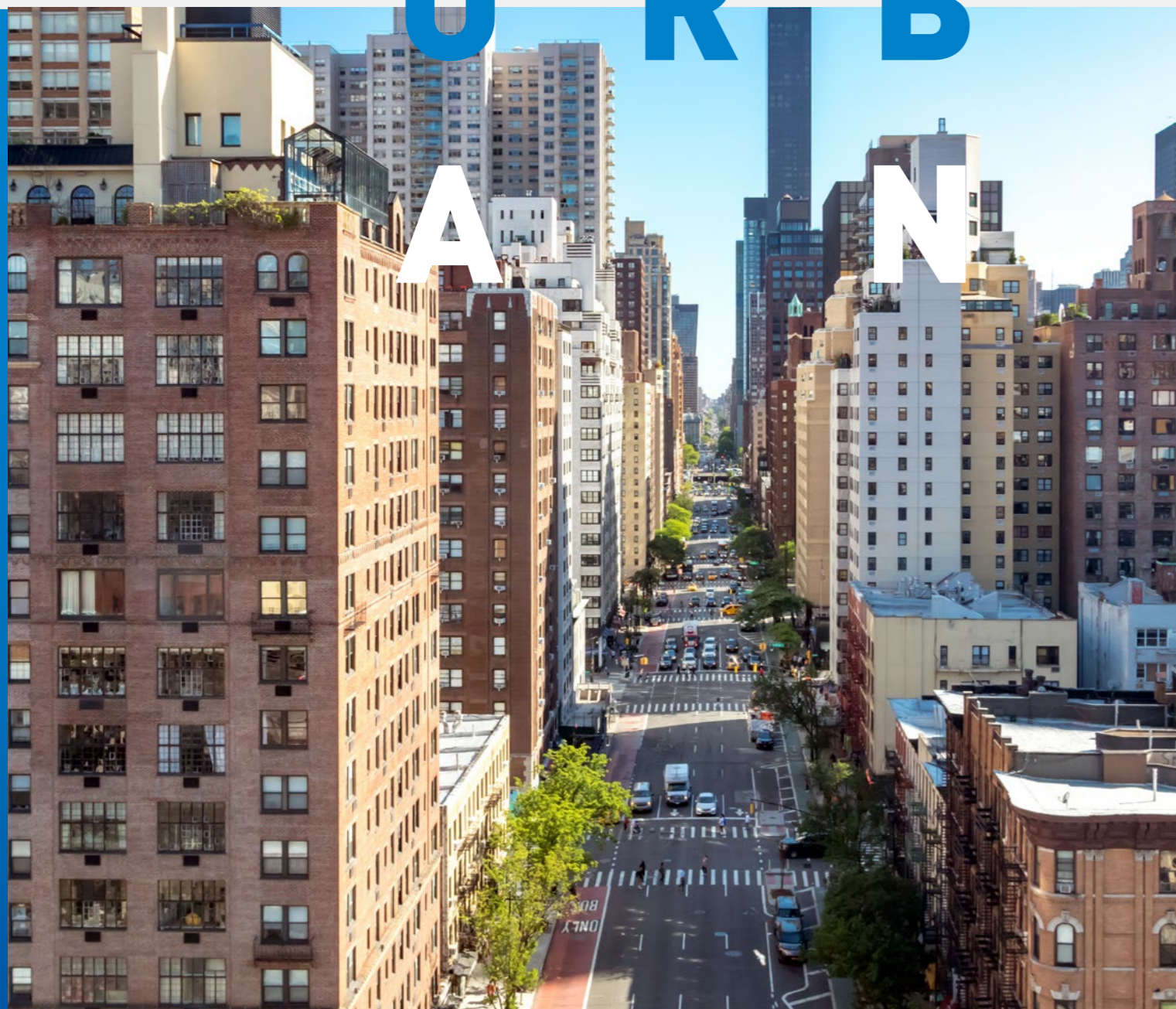

342 **EDITOR**

344 **HYDE**

352 **ELLA**

356 **TOWN**

COMFORT

COMFORT

FITNESS

FITNESS

COMMUTING

COMMUTING



EDITOR

Simplicity can be a virtue. When we asked our designers to come up with the ultimate urban assault bike, the Editor was the result. Light and responsive with great handling and equipment specially selected to keep you riding rather than maintaining your bike, it's all you need for the urban jungle.

HYDE

A bicycle is, at heart, a very simple device. With the Hyde, we've taken that to heart. Stripped to the bare essentials, this is a nimble machine built for scything through the traffic and getting from A to B with the minimum of fuss. Jump on, ride, arrive. If only all of life were that simple.

ELLA

Is beauty more than skin deep? At CUBE, we reckon it is. That's why the Ella's retro styling and colour-coordinated accessories are only part of the story. Underneath you'll find a practical, easy to ride and versatile bike that'll slot into your busy life effortlessly. The fact that it's so good-looking is a bonus.

TOWN

Modern life is busy, but the Town will fit right in and make your life easier. Light, well equipped and built to tackle everything from a commute across town to longer rides at the weekend, it's the easy-to-live-with companion that you'll soon be wondering how you managed without.

FOR us #Commuters

CUBE's engineers took everything they'd learned from building fast, lightweight mountain bike frames and put it to good use in the Editor. The frame is built with torsional rigidity – and therefore efficient pedalling – in mind. We used double-buttressed aluminium tubes and our advanced mechanical forming process to put material where it's needed for strength and remove it where possible to save weight. An eccentric bottom bracket enables belt tension to be adjusted easily, and ultra-neat mudguard and luggage carrier mounts enable the easy addition of these accessories without spoiling the clean lines of your bike. And the sleek, lightweight fork performs as good as it looks, giving precise and nimble steering and a surprising degree of comfort on rough city streets.



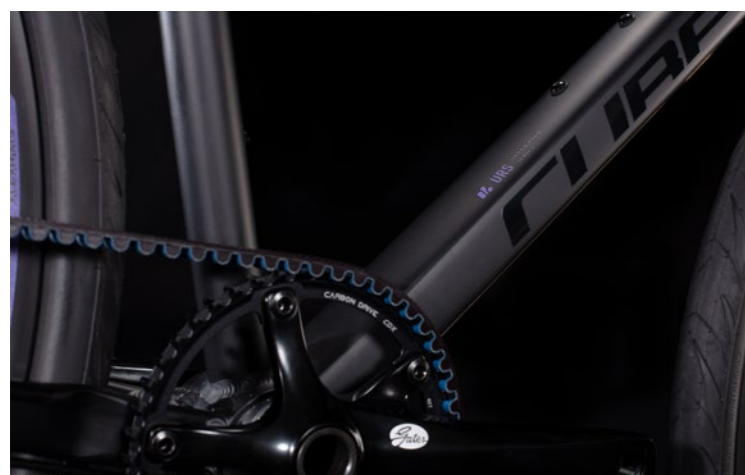

When we set out to design the Editor, we had a very simple goal in mind: make the ultimate urban assault bike. Ultimate looks, ultimate comfort, ultimate speed, ultimate practicality. That's why we started with our advanced aluminium double-butted frame with a sleek rigid fork and hidden rack and mudguard mounts. Lightweight, incredibly efficient and superbly practical, like all our frames it's been through our 24/7 torture-testing lab to verify its strength, durability and safety. We didn't compromise on the transmission, selecting Shimano's superb Alfine 11-speed hub gear and combining it with a Gates belt drive for silent running and practical low-maintenance performance. The eccentric bottom bracket makes belt tension adjustment a cinch and we guarantee you won't miss an oily chain. Powerful Shimano hydraulic disc brakes offer reliable stopping even when the weather isn't cooperating. There are even two bottle cage mounts, so you can stay hydrated if your Editor tempts you into a longer excursion at the weekends. Because after all, one of the beauties of an ultra-efficient urban bike is that it also makes it easier to escape the city...

-  **FRAME#**Aluminium Superlite Urban Double Butted
- SIZE#**Men: 46, 50, 54, 58, 62
- FORK#**Aluminium Rigid Fork

-  **HEADSET#**SA Orbit Z Semi-Integrated 1 1/8"
- STEM#**CUBE Performance Stem Pro, 31.8mm
- HANDLEBAR#**CUBE Flat Race Bar, 660mm
- GRIPS#**Natural Fit Comfort
- SHIFTERS#**Shimano Alfine SL-S700
- BRAKE SYSTEM#**Shimano Deore BR-M6000, Hydr. Disc Brake (160/160)
- CRANKSET#**Gates CDX Center Track, 46T, BB Gates
- SPROCKET#**Gates CDX Center Track, 22T
- CHAIN#**Gates CDX, 113T
- RIMS#**CUBE UX24, 32H, Disc, Tubeless Ready
- FRONT HUB#**Shimano Deore HB-M6000, Centerlock
- REAR HUB#**Shimano Alfine SG-S7001, 11-Speed
- TYRES#**Schwalbe Marathon Supreme, Kevlar, 42-622
- PEDALS#**P 615M
- SADDLE#**Selle Royal Prestige
- SEAT POST#**CUBE Performance Post, 27.2mm
- SEAT CLAMP#**CUBE Screwlock, 31.8mm
- BELL#**Knog Oi

-  **WEIGHT#**1,7 kg

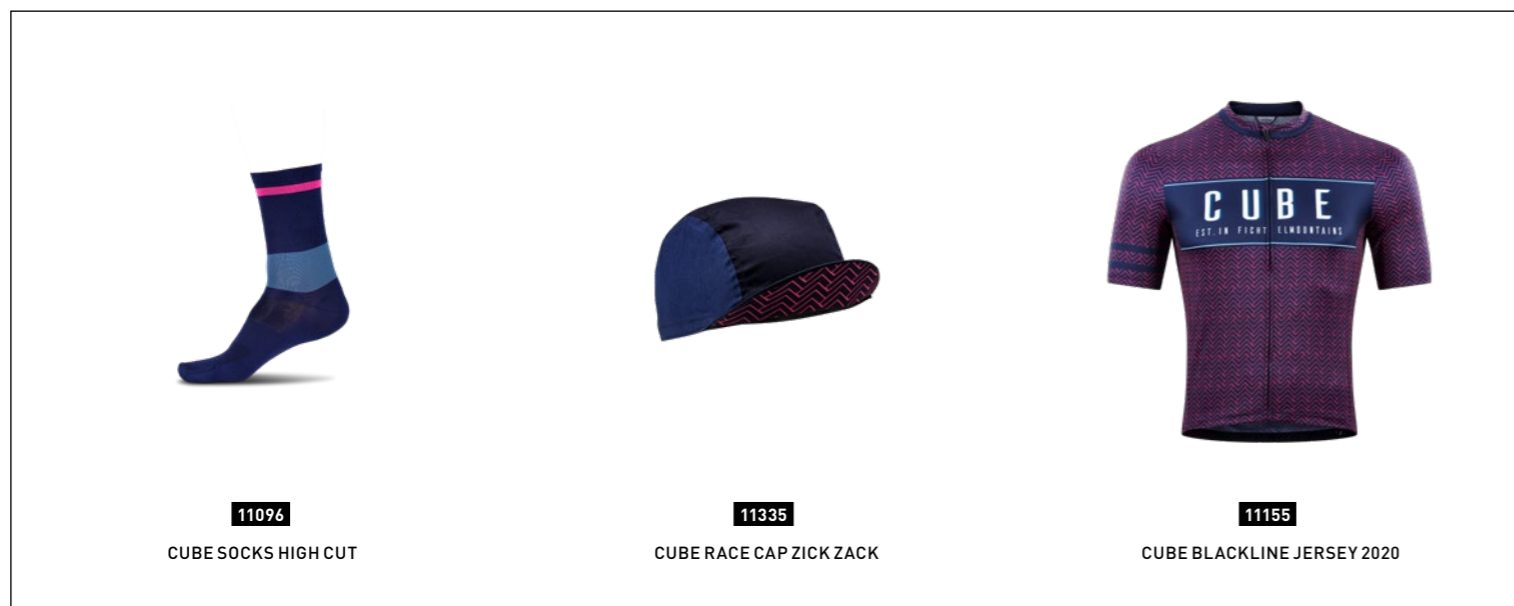

11096
CUBE SOCKS HIGH CUT

11335
CUBE RACE CAP ZICK ZACK

11155
CUBE BLACKLINE JERSEY 2020

-  **SPARE PARTS#**
- 10324** CUBE Headset Orbit Z
- 13550** Inner Tube 28" TREKKING SV 40 mm

HYDE RACE

347300 | Trapeze | black 'n' green





HYDE RACE

347300 | black 'n' green



Need to get from A to B across town as fast as possible? The Hyde Race is the right tool for the job. Light, quick and comfortable, it's the city bike of choice for discerning riders looking for an efficient, environmentally-friendly means of transport. It is, in many ways, a masterpiece of understatement. The silent Gates Carbon Drive is an important part of its appeal, rendering oil-stained clothing – not to mention regular maintenance – a thing of the past. And it goes without saying that 'Race' isn't just a marketing tag that we've tacked on. This bike has earned its speedy moniker, because we sweated the details to make it as rapid as possible in the urban jungle. The frame is built with torsional rigidity – and therefore efficient pedalling – in mind. Double-butted tubes and our advanced mechanical forming process make it both light and exceptionally strong. And the sleek, lightweight fork performs just as well as it looks, giving precise and nimble steering. From its state-of-the-art Shimano Alfine hub to fast-rolling Schwalbe tyres and stealth looks, the Hyde Race is a pure-bred urban speed machine.

-  **FRAME** #Aluminium Superlite Urban Double Butted
 - SIZE** #Men: 46, 50, 54, 58, 62, Trapeze: 46, 50, 54
 - FORK** #Aluminium Rigid Fork
-
-  **HEADSET** #SA No.10, Semi-Integrated
 - STEM** #CUBE Performance Stem Pro, 31.8mm
 - HANDLEBAR** #CUBE Flat Race Bar, 660mm
 - GRIPS** #Natural Fit Comfort
 - SHIFTERS** #Shimano Alfine SL-S7000
 - BRAKE SYSTEM** #Shimano BR-MT200, Hydr. Disc Brake (160/160)
 - CRANKSET** #Gates S150 CDN, 46T, 170mm, BB Thun Zumba
 - CASSETTE** #Gates Rear Sprocket CDN, 22T
 - CHAIN** #Gates CDN, 113T
 - RIMS** #CUBE UX24, 32H, Disc, Tubeless Ready
 - FRONT HUB** #Shimano Deore HB-M6000, Centerlock
 - REAR HUB** #Shimano Alfine SG-S700, 8-Speed
 - TYRES** #Schwalbe Marathon Supreme, Kevlar, 42-622
 - PEDALS** #P 615M
 - SADDLE** #Selle Royal Prestige
 - SEAT POST** #CUBE Performance Post, 27.2mm
 - SEAT CLAMP** #CUBE Screwlock, 31.8mm
 - BELL** #knog Oi

 **WEIGHT** #1,9 kg

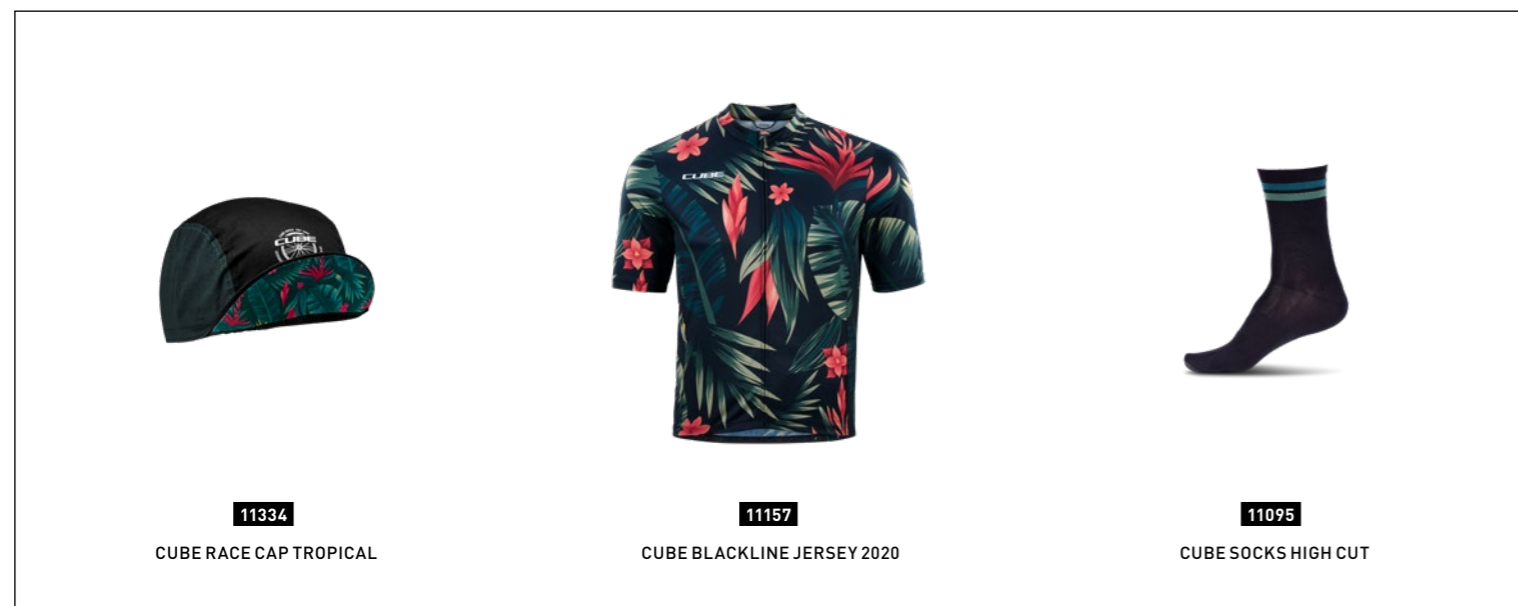

11334
CUBE RACE CAP TROPICAL

11157
CUBE BLACKLINE JERSEY 2020

11095
CUBE SOCKS HIGH CUT

-  **SPARE PARTS** #
- 10324 CUBE Headset Orbit Z
- 13550 Inner Tube 28" TREKKING SV 40 mm

HYDE PRO

347200 | Trapeze | black 'n' blue



HYDE PRO

347200 | black 'n' blue

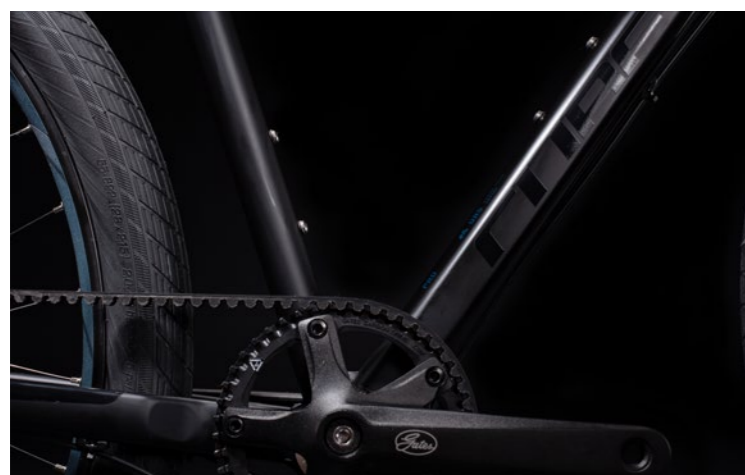

Don't be fooled by its deliberately understated looks. Under its unassuming exterior the Hyde Pro is a true urban lifestyle bike for riders who value both form and function. Simple, elegant and light, its true strength lies in its adaptability – because this is a bike that's capable of taking on pretty much anything. Its light but stiff aluminium frame – built from a double-butted tubeset to save weight without sacrificing strength or safety – is based on our 29er hardtail mountain bike model. That's good news, because it's designed to be tough, comfortable and versatile. The tried and tested 8-speed hub gear with belt drive perfectly fulfils the demands of an urban all-rounder, serving up the gears you need while demanding practically nothing in the way of ongoing maintenance. Hydraulic Shimano disc brakes provide powerful, easy-to-control stopping ability in any weather conditions, while the sleek rigid fork contributes to the Hyde Pro's overall low weight. We even made it easy to add a luggage carrier and mudguards, with sleekly hidden mounting points that preserve the bike's clean lines. Put it all together, and the Hyde Pro is the nimble, adaptable companion that you need for navigating the urban jungle not just safely, but in style and comfort.

- FRAME** #Aluminium Superlite Urban 29 Double Butted
 - SIZE** #Men: 46, 50, 54, 58, 62, Trapeze: 46, 50, 54
 - FORK** #Aluminium Rigid Fork 29" Tapered
-
- HEADSET** #SA Orbit 1.5B ZS-1, Semi-Integrated, Top 1 1/8" Bottom 1 1/2"
 - STEM** #CUBE Performance Stem Pro, 31.8mm
 - HANDLEBAR** #CUBE Flat Race Bar, 660mm
 - GRIPS** #Natural Fit Comfort
 - SHIFTERS** #Shimano Alfine SL-S503
 - BRAKE SYSTEM** #Shimano BR-MT200, Hydr. Disc Brake (160/160)
 - CRANKSET** #Gates S150 CDN, 46T, 170mm, BB Thun Zumba
 - CASSETTE** #Gates Rear Sprocket CDN, 22T
 - CHAIN** #Gates CDN, 120T
 - RIMS** #CUBE UX24, 32H, Disc, Tubeless Ready
 - FRONT HUB** #Shimano HB-M3050, Centerlock
 - REAR HUB** #Shimano Nexus SG-C6001-8D, 8-Speed
 - TYRES** #Schwalbe Big Apple, Active, 29-2.15
 - PEDALS** #CUBE PP MTB
 - SADDLE** #Felle Royal Prestige
 - SEAT POST** #CUBE Performance Post, 27.2mm
 - SEAT CLAMP** #CUBE Screwlock, 31.8mm
 - BELL** #knog Oi
-
- WEIGHT** #3.5 kg

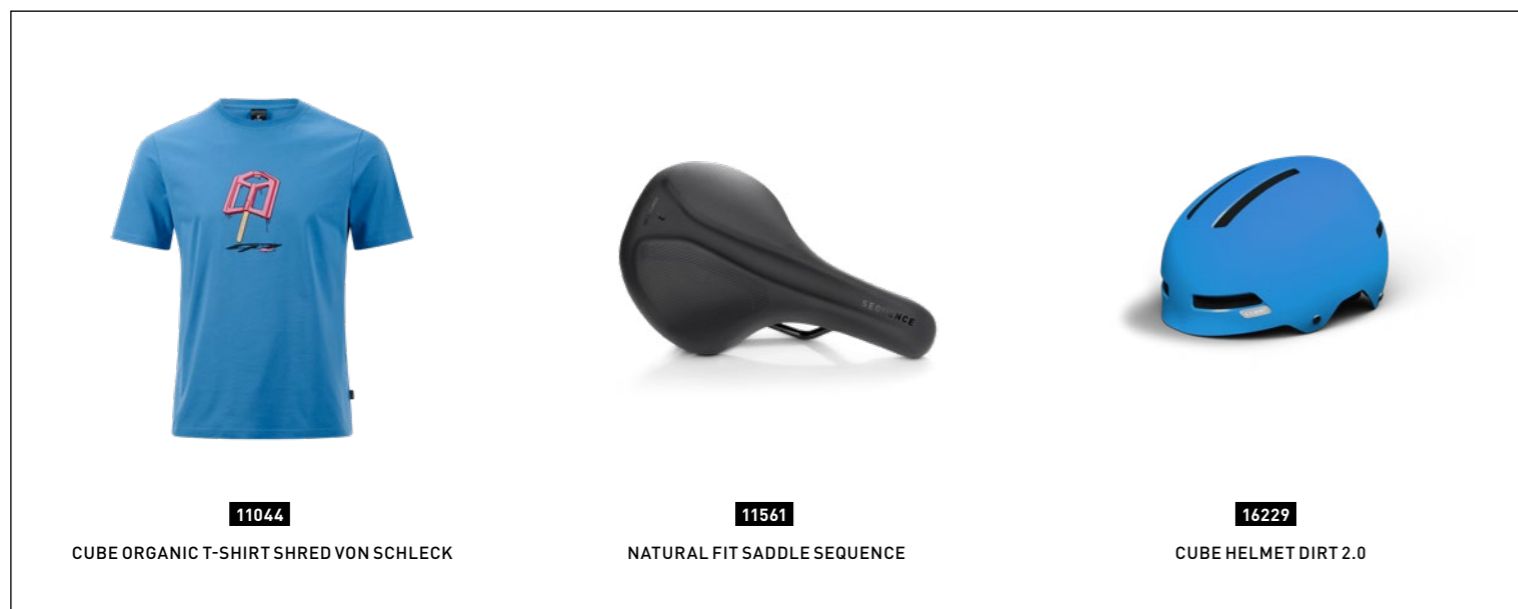

11044
CUBE ORGANIC T-SHIRT SHRED VON SCHLECK

11561
NATURAL FIT SADDLE SEQUENCE

16229
CUBE HELMET DIRT 2.0

- SPARE PARTS** #
- 10325 CUBE Headset Orbit Z-t + 1 1/8 crown race
- 13543 Inner Tube 27,5"/29" MTB AGV 40 mm



There's no getting away from the reality: getting around town quickly and easily these days means a switch from cars to bikes. The Hyde is part of this move; a bike geared specifically towards the demands of the urban environment. It makes the advantages of two wheels over four obvious. With a light frame and reliable components, this svelte urban machine is the ideal companion for tackling city streets in comfort. Neatly integrated luggage carrier and mudguard mounting points make attaching these accessories simple, so you can easily customise your Hyde to fit seamlessly into your life. The sleek rigid fork matches the frame's understated looks perfectly and offers crisp, precise steering to complement its low weight. Powerful hydraulic disc brakes provide reliable all-weather stopping power, fast-rolling tyres help get you to your destination speedily and a slick-shifting Shimano 3x9 transmission gives you the gear range you need to cope easily with any situation. It's all the bike you need to help you beat the traffic across town. More than that, it's light and lively enough to do double duty as your weekend ticket out into the countryside. One bike, many reasons: that's the Hyde.

-  **FRAME** #Aluminium Superlite Urban 29 Double Butted
- SIZE** #Men: 46, 50, 54, 58, 62, Trapeze: 46, 50, 54
- FORK** #Aluminium Rigid Fork 29" Tapered

-  **HEADSET** #CUBE H868P, Semi-Integrated
- STEM** #CUBE Performance Stem Pro, 31.8mm
- HANDLEBAR** #CUBE Flat Race Bar, 660mm
- GRIPS** #CUBE Performance Grip
- REAR DERAILLEUR** #Shimano Deore RD-M592, 9-Speed
- SHIFTERS** #Shimano SL-M3000, Rapidfire-Plus
- FRONT DERAILLEUR** #Shimano Acera FD-T3000, Topswing, 31.8mm
- BRAKE SYSTEM** #Shimano BR-MT200, Hydr. Disc Brake (160/160)
- CRANKSET** #Shimano Acera FC-M371, 48x36x26T, 175mm, Chainguard
- CASSETTE** #Shimano CS-HG200, 11-34T
- CHAIN** #MC X9
- RIMS** #CUBE UX24, 32H, Disc, Tubeless Ready
- FRONT HUB** #Shimano HB-TX505, QR, Centerlock
- REAR HUB** #Shimano FH-TX505, QR, Centerlock
- TYRES** #Schwalbe Big Apple, Active, 29-2.15
- PEDALS** #CUBE PP MTB
- SADDLE** #Selle Royal Prestige
- SEAT POST** #CUBE Performance Post, 27.2mm
- SEATCLAMP** #CUBE Screwlock, 31.8mm

 **WEIGHT** #3,4 kg



93017
MUDGUARD SET MTB 65 WITH STAYS



16236
CUBE HELMET EVOY HYBRID



11411
SQAURE WIND JACKET PERFORMANCE

-  **SPARE PARTS**
- 10148** CUBE Hanger #148 short version
- 10325** CUBE Headset Orbit Z-t + 1 1/8 crown race
- 13543** Inner Tube 27,5"/29" MTB AGV 40 mm

FOR us #Individualists

Building a light, strong, stylish step-through frame isn't as easy as it looks. Balancing low weight, comfort, style and safety is what gets our engineering team out of bed in the morning – and this is the result. Efficient Comfort Geometry (ECG) makes every ride a pleasure and every turn a breeze, and of course you can rest assured that the frame has passed all our stringent in-house safety tests. The luggage carrier integrates neatly into the frame's elegant structure, but it's also a great way to carry around whatever you need to take with you. Cables routed through the down tube reduce the need for maintenance and keep your gears shifting smoothly, while colour-coordinated accessories complete the look.



ELLA RIDE

349250 green'n'cream



ELLA RIDE

349260 red'n'cream



The stylish and practical Ella Ride is the perfect companion for your active, outdoor lifestyle. Taking its inspiration from our popular Ella hybrids, our engineers have worked hard to blend function, fashion, comfort and safety into a stylish, modern bike that you'll be proud to be seen on. With our cutting-edge in-house test lab working 24/7 on safety tests, you can rest assured that your Ella Ride is robust enough to stand up to the rough and tumble of everyday life. Just as important, it's great to look at. With its retro styling and colour-coordinated accessories, it combines the comfort of our Efficient Comfort Geometry with the convenience and reliability of components from Shimano and Suntour, so all you need to do is step on and ride. With its plus suspension fork, full mudguards, lights, chainguard and kickstand, the Ella Ride has everything you need... and nothing that you don't.

FRAME Aluminium Superlite Trekking Comfort IC 2.0 Double Butted
SIZE Easy Entry: 45, 49, 53
FORK Suntour NEX, 50mm

HEADSET SA No.10, Semi-Integrated
STEM CUBE Comfort City Stem, 31.8mm
HANDLEBAR CUBE Comfort Shape Bar
GRIPS CUBE Retro
REAR DERAILLEUR Shimano RD-M360, 8-Speed
SHIFTERS Shimano SL-M315, Rapidfire Plus
FRONT DERAILLEUR Shimano FD-M310, Topswing, 31.8mm
BRAKE SYSTEM V-Brake
CRANKSET Shimano FC-T801, 48x36x26T, 175mm
CASSETTE Shimano CS-HG200, 12-32T
CHAIN MC Z51
RIMS CUBE SX24, 36H, V-Brake
FRONT HUB Shimano DH-C3000, Hub Dynamo, Nut
REAR HUB Shimano FH-TX500, Nut
TYRES Schwalbe Little Big Ben, Active, 40-622
PEDALS CUBE PP MTB
SADDLE CUBE Retro
SEAT POST CUBE Performance Post, 27.2mm
SEATCLAMP CUBE Screwlock, 31.8mm
FRONT LIGHT relock LS582 Retro
REAR LIGHT Herrmans H-Trace
KICKSTAND CUBEstand Cmpt
MUDGUARDS KS Chrom Shiny
BELL CUBE Classic
CARRIER CUBE Integrated Carrier 2.0, CUBE Adapter Compatible, SnapIt Compatible and Rail

WEIGHT 6,7 kg

SPARE PARTS
10148 CUBE Hanger #148 short version
10324 CUBE Headset Orbit Z
13548 Inner Tube 28" TREKKING AGV 40 mm

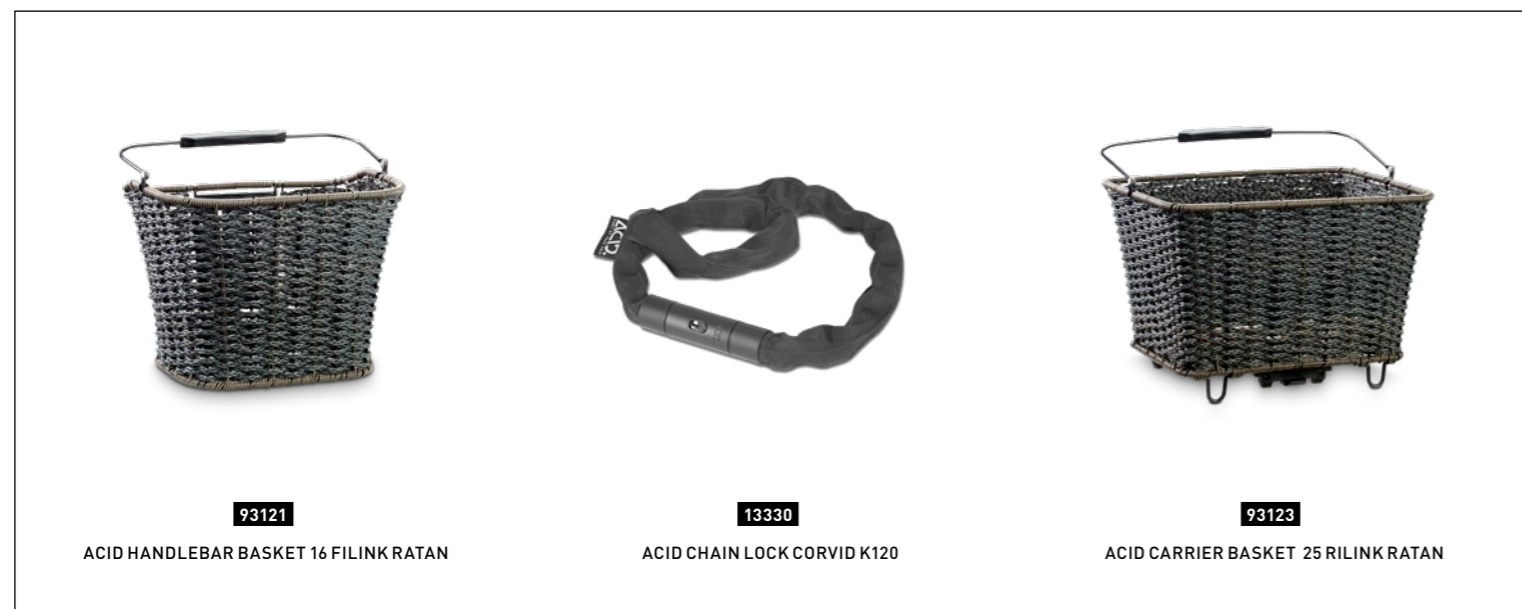

93121 ACID HANDLEBAR BASKET 16 FILINK RATAN

13330 ACID CHAIN LOCK CORVID K120

93123 ACID CARRIER BASKET 25 RILINK RATAN

ELLA CRUISE

349210 yellow 'n' white



ELLA CRUISE

349200 oldblue 'n' blue

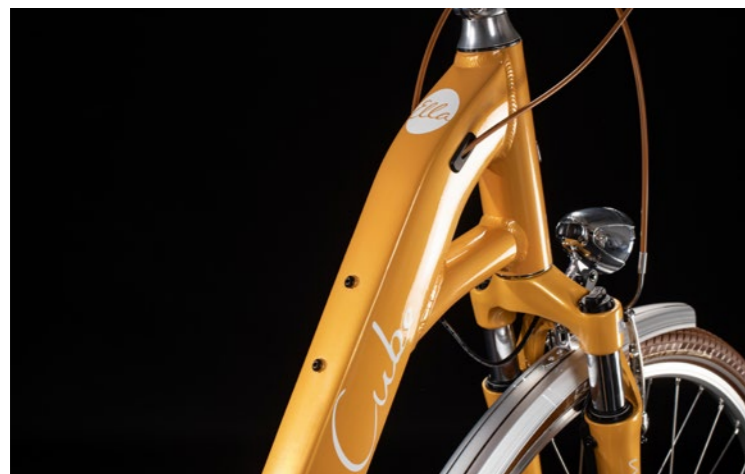

The stylish, comfortable Ella Cruise will slot so easily into your life, you'll wonder how you ever managed without it. Elegant and refined with its signature retro styling cues, it blends effortless style with genuine practicality, comfort and ease of use. The frame isn't just about great looks, it's also designed to be super easy to step in and out of. A comfortable ride position and safe, intuitive handling are part of the package, and we've selected components like the Shimano 8-speed hub gear specifically for their reliability, so you can just concentrate on enjoying the ride. The colour-coded luggage carrier, chain guard and suspension fork complete the look, and we added dynamo-powered lights, full-length mudguards and a kickstand, too – so you'll be ready for any two-wheeled journey.

FRAME# Aluminium Superlite Trekking Comfort IC 2.0 Double Butted
SIZE# Easy Entry: 45, 49, 53
FORK# R Suntour NEX, 50mm

HEADSET# SA No.10, Semi-Integrated
STEM# CUBE Comfort City Stem, 31.8mm
HANDLEBAR# CUBE Comfort Shape Bar
GRIPS# CUBE Retro
SHIFTERS# Shimano Nexus SL-C6000
BRAKE SYSTEM# V-Brake
CRANKSET# Shimano Nexus FC-C6000, BB-UN26K, 38T
SPROCKET# Shimano Nexus, 20T
RIMS# CUBE SX24, 36H, V-Brake
FRONT HUB# Shimano DH-C3000, Hub Dynamo, Nut
REAR HUB# Shimano Nexus SG-C6001, 8-Speed
TYRES# Schwalbe Little Big Ben, Active, 40-622
PEDALS# CUBE PP MTB
SADDLE# CUBE Retro
SEAT POST# CUBE Performance Post, 27.2mm
SEATCLAMP# CUBE Screwlock, 31.8mm
FRONT LIGHT# Relock LS582 Retro
REAR LIGHT# Herrmans H-Trace
KICKSTAND# CUBEstand Cmpt
MUDGUARDS# KS Chrom Shiny
BELL# CUBE Classic
CARRIER# CUBE Integrated Carrier 2.0, CUBE Adapter Compatible, SnapIt Compatible and Rail

WEIGHT# 6.9 kg

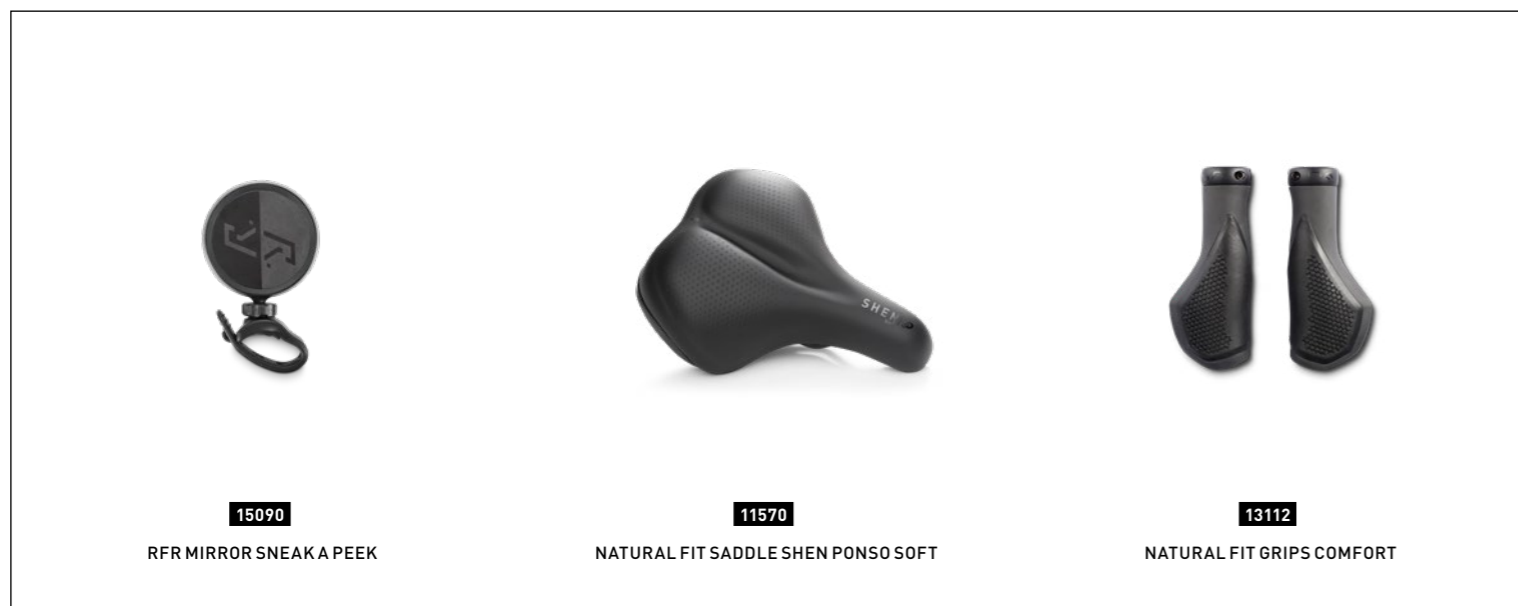

15090
RFR MIRROR SNEAKA PEEK

11570
NATURAL FIT SADDLE SHEN PONSO SOFT

13112
NATURAL FIT GRIPS COMFORT

SPARE PARTS#
10324 CUBE Headset Orbit Z
13548 Inner Tube 28" TREKKING AGV 40 mm

TOWN PRO

349100 grey'n'white



TOWN PRO

349110 red'n'black



349100 | Easy Entry grey'n'white



349110 | Easy Entry red'n'black



We know that life doesn't always stop for you to maintain your bike. That's why we worked hard to make sure that the Town Pro is easy to live with – because you need a bike that's comfortable, versatile and always ready to just grab and go. We started with a stylish frame design featuring the same kind of double-butted, Superlite aluminium tubes that we use in many of our more expensive bikes. They're there to save weight where possible, making for an easier and more comfortable ride without compromising strength or durability. The included luggage carrier is stable and sleek, so you can take what you need wherever you need to go. The easy-to-use Shimano 8-speed hub gears and Suntour suspension fork are there to make your life easier, and we also added mudguards, lights and a kickstand – so there's no need to accessorise your brand-new bike. We even made two versions – the classic men's double diamond frame and a step-through frame for easy entry – and added a suspension seat post for more comfort. Now when you need a bike to get to work, run to the shops or just head out for some fresh air, the Town Pro will always be ready for you.

-  **FRAME** #Aluminium Superlite Trekking Comfort Double Butted
- SIZE** #Men: 46, 50, 54, 58, 62, Easy Entry: 45, 49, 53
- FORK** #SR Suntour NEX, 63mm

-  **HEADSET** #CUBE H863, Semi-Integrated
- STEM** #CUBE Comfort City Stem, 31.8mm
- HANDLEBAR** #CUBE Rise Trail Bar, 680mm; EE: CUBE Comfort Shape Bar
- GRIPS** #Comfort
- SHIFTERS** #Shimano Nexus SL-8531
- BRAKE SYSTEM** #V-Brake, EE: V-Brake, Coaster Brake
- BRAKE LEVERS** #ektro 520 Aluminium Black
- CRANKSET** #Shimano FC-C6000, 38T, BB-UN100, 170mm
- SPROCKET** #Shimano Nexus, 20T
- CHAIN** #MC Z72
- RIMS** #CUBE SX24, 36H, V-Brake
- FRONT HUB** #Shimano DH-C3000, Hub Dynamo, Nut
- REAR HUB** #Shimano Nexus SG-C6000, Nut, 8-Speed, EE: Shimano Nexus SG-C6000, Coaster Brake, Nut, 8-Speed
- TYRES** #mpac Streetpac, Active, 40-622
- PEDALS** #CUBE PP Trekking
- SADDLE** #Natural Fit Sequence Comfort
- SEAT POST** #CUBE Suspension Seatpost, 31.8mm
- SEATCLAMP** #CUBE Screwlock, 31.8mm
- FRONT LIGHT** #ED 15 Lux
- REAR LIGHT** #ED Steady Light
- KICKSTAND** #CUBEstand Cmpt
- MUDGUARDS** #CUBE Black Shiny
- BELL** #Mini
- CARRIER** #CID Semi-Integrated Carrier, ACID RILink Adapter Compatible

 **WEIGHT** #6,9 kg

-  **SPARE PARTS** #
- 10324** CUBE Headset Orbit Z
- 13548** Inner Tube 28" TREKKING AGV 40 mm



12022

RFR REAR CARRIER BAG TOURER 10/2



93270

ACID PEDALS FLAT C1-IB HYBRID



16235

CUBE HELMET EVOY HYBRID



KIDS



CUBIE	NEWCOMER	YOUNGSTER	ROOKIE
-------	----------	-----------	--------

- 360 **CUBIE 120** | 12
- 364 **CUBIE 160** | 16
- 368 **CUBIE 180** | 18
- 370 **KID 200** | 20
- 384 **KID 240** | 24
- 408 **KID 260** | 26
- 412 **REACTION C:62** | 27.5, 29
- 418 **STEREO YOUTH 120** | 27.5

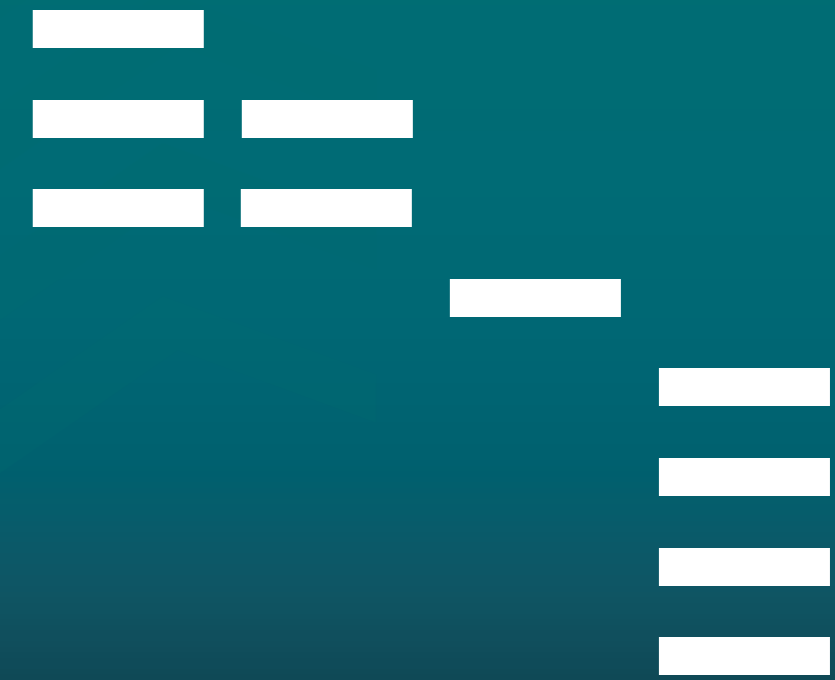

CUBIE

Start them right, start them young. Designed with safety and fun in mind, our Cubie series is the perfect introduction to the joys of life on two wheels. Whether you opt for the Walk version or go straight to pedals, your little ones can't get a better biking beginning than this.

KID

Kids of all ages love bikes. We know that, which is why our Kid range covers a range of ages and uses, from single gear starter bikes to disc brake and suspension-fork equipped mountain bikes for ambitious junior riders. Whatever your child is into, we've got a bike to match.

ELLA

Girls just wanna have fun. The Ella series combines the rugged capability of our junior mountain bikes with a stylish easy entry frame and a full complement of accessories including luggage carrier, mudguards and lights. You know she's safe; she's just enjoying her riding.

REACTION YOUTH

The mountain bike bug can bite. Hard, and early. That's where the Reaction Youth comes in. Light, nimble and equipped to take any off-road challenge in its stride, it's the hardtail of choice for aspiring junior racers and adventurers alike. Feed their passion – give them a Reaction.

STEREO 120 YOUTH

Our Stereo 120 is a legend in its own lifetime - and now youngsters can enjoy the same comfort, handling and performance in a frame that's specifically designed for them. Perfectly proportioned and using the same suspension kinematics and geometry principles as the full size Stereo 120, it's the ideal bike for your little ripper.

CUBIE 120 WALK GIRL

320100 lightblue'n'white

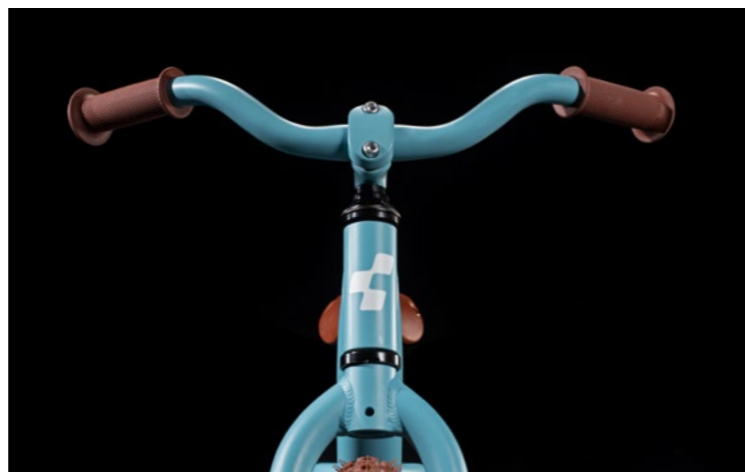

16261
CUBE HELMET FINK



15085
RFR BELL BUDDYS CROWN



10748
CUBE JUNIOR JERSEY

CUBIE 120 WALK

320110 actionteam blue



The Cubie 120 Walk is designed to ease your little one into the wonderful world of bikes, building confidence in a fun and safe way. Despite its simple appearance, it's stacked with our usual attention to detail. The 6061 aluminium frame and fork are really light, and perfectly proportioned for small children. Low standover gives plenty of freedom of movement and helps to build confidence, and we paid particular attention to ensuring that all frame parts are finished with smooth edges and corners to help reduce the chance of injury. There's even a special headset setup with an integrated steering angle limiter, to help prevent accidents caused by over-enthusiastic steering. The included second seat post gives plenty of scope for growth, and proper pneumatic tyres provide comfort, roll easily and help make the ride fun. As for the lack of brakes... well, experience has shown that kids this young don't have the finger strength and coordination required to brake safely, which is why this is a bike that's both propelled and stopped by your child's feet. It's the ideal way to discover the fine art of balancing, to build confidence and to generate enthusiasm for the joy of riding bikes.

 **FRAME**#Alu Lite 6061
SIZE#2"
FORK#Rigid Alloy fork

 **HEADSET**#CUBE with Steering End Stop
STEM#CUBE Alu Lite
HANDLEBAR#CUBE Alu Lite, 420mm
GRIPS#CUBE Kid Grips
RIMS#Aluminium
FRONT HUB#CUBE Aluminium
REAR HUB#CUBE Aluminium
TYRES#Kenda Team CUBE
SADDLE#CUBE Kid
SEAT POST#CUBE Alu Lite (longer one included)
SEATCLAMP#CUBE
BELL#luvo

 **WEIGHT**#,9 kg

 **SPARE PARTS**#
13528 Inner Tube 12" JUNIOR/MTB AV 35 mm
13529 Inner Tube 12" JUNIOR/MTB DV 26 mm

CUBIE 120 GIRL

320160 blue'n'mint



11052

CUBE JUNIOR ORGANIC T-SHIRT FLORAL BIKE



16292

CUBE HELMET FINK



11099

CUBE JUNIOR FREERIDE CAP X ACTIONTEAM

CUBIE 120

320150 green'n'blue



Balance is key to learning to ride, but once you're there... the urge to pedal and move faster won't be far behind. That's why we created the Cubie 120 – for kids who can't wait to power themselves. A lightweight aluminium frame and fork has allowed us to build a smaller, perfectly formed bike that's clearly a mini version of mum and dad's bikes. The tough 6061 aluminium chassis is built to handle the rough and tumble of exploratory play, and our engineers paid particular attention to ensuring that all edges and corners are as smooth as possible to help reduce the chance of injury. A coaster brake at the rear and light, smooth rim brake at the front – with a lever designed specifically for small hands – make it safe and easy to slow down and stop, even for the most enthusiastic of youngsters. There's a built-in rear mudguard, a Hebie Chainlooper to protect your little one's legs from the transmission, and the saddle features an easy carry handle for those times when it all gets a bit too much and mum or dad has to carry the bike home. If there's a better way to learn to pedal, have fun and build confidence at the same time, we don't know what it is.

 **FRAME** #Alu Lite 6061
SIZE #2"
FORK #Rigid Alloy fork

 **HEADSET** #CUBE A-Headset
STEM #CUBE Alu Lite
HANDLEBAR #CUBE Alu Lite, 450mm
GRIPS #CUBE Kid Grips
BRAKE SYSTEM #Front: Alloy Cantilever; Rear: Coaster Brake
CRANKSET #Prowheel, 25T, 89mm with Chainlooper
CHAIN #MC S1
RIMS #Aluminium
FRONT HUB #CUBE Aluminium
REAR HUB #CUBE Aluminium
TYRES #CUBE IMPAC Smartpac
PEDALS #CUBE Kid
SADDLE #CUBE Kid
SEAT POST #CUBE Alu Lite
SEATCLAMP #CUBE
BELL #luvo

 **WEIGHT** #,9 kg

 **SPARE PARTS** #
13528 Inner Tube 12" JUNIOR/MTB AV 35 mm
13529 Inner Tube 12" JUNIOR/MTB DV 26 mm

CUBIE 160 GIRL

321110 berry'n'pink'n'blue

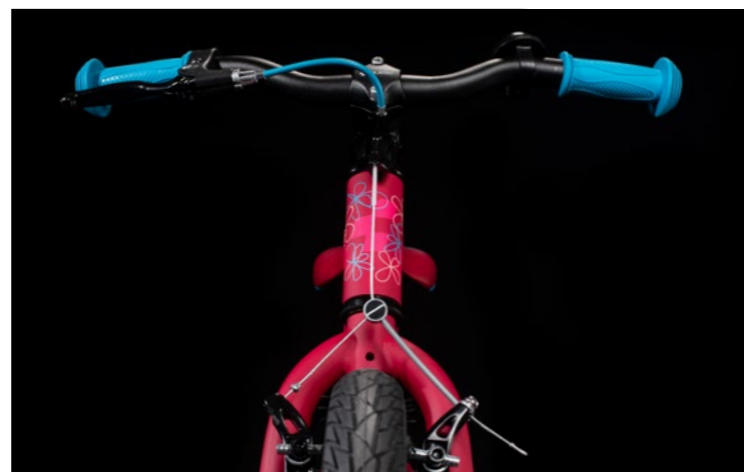

With looks borrowed straight from CUBE's mountain bike range and a design tailored specially for young riders, the Cubie 160 is the ideal introduction to the joys of pedal power. Our engineers started with a geometry designed specifically around a child's needs, blending the fun of responsive handling with the safety of stable, predictable steering. Sturdy and lightweight 6061 aluminium tubes build into a structure that's tough enough to stand up to enthusiastic use, but light enough to inspire – and of course, smooth edges and corners wherever possible help minimise the risk of injury. Sensibly proportioned, child-friendly components are designed to last the course, so the rough and tumble of learning to ride won't result in broken dreams. The simplicity of a coaster rear brake, combined with a smooth rim brake controlled by a lever tailored for small hands at the front, means your child can learn how to control their speed as their confidence grows. We've fitted a new alloy crank and a Hebie Chainlooper to keep the transmission safely enclosed, CUBE tyres with lots of grip, a comfortable ride and the rugged looks of a full-size mountain bike, and a motocross-inspired rear mudguard. It's everything a future mountain bike rider could want.

-  **FRAME**#Alu Lite 6061
- SIZE**#6"
- FORK**#Rigid Hi-Ten fork

-  **HEADSET**#CUBE A-Headset
- STEM**#CUBE Alu Lite
- HANDLEBAR**#CUBE Alu Lite, 450mm
- GRIPS**#CUBE Kid Grips
- BRAKE SYSTEM**#Front: Alloy Cantilever; Rear: Coaster Brake
- CRANKSET**#amox, 25T, 114mm with Chainlooper
- CHAIN**#MC S1
- RIMS**#aluminium
- FRONT HUB**#CUBE Aluminium
- REAR HUB**#CUBE Aluminium
- TYRES**#CUBE IMPAC Streetpac
- PEDALS**#CUBE Kid
- SADDLE**#CUBE Kid
- SEAT POST**#CUBE Alu Lite
- SEATCLAMP**#CUBE
- BELL**#luvo

 **WEIGHT**#,5 kg

-  **SPARE PARTS**#
- 13530** Inner Tube 16" JUNIOR/MTB AV 35 mm
- 13531** Inner Tube 16" JUNIOR/MTB DV 26 mm

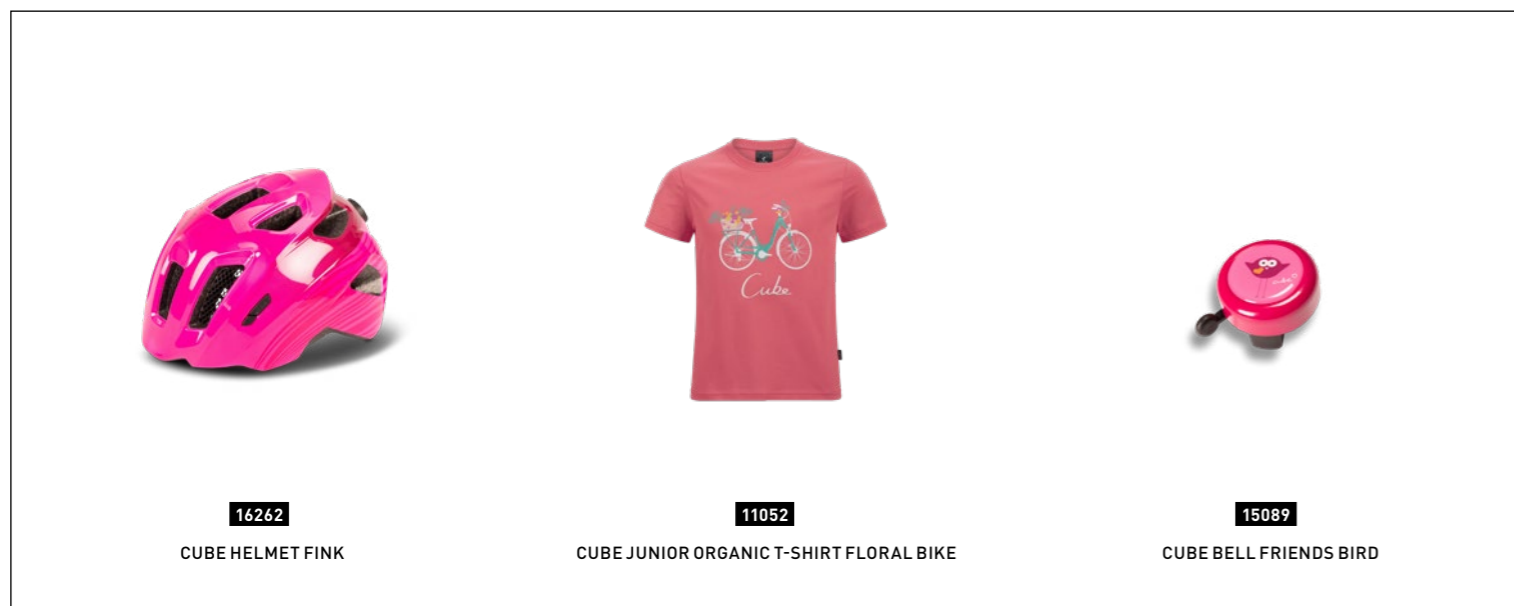

16262
CUBE HELMET FINK

11052
CUBE JUNIOR ORGANIC T-SHIRT FLORAL BIKE

15089
CUBE BELL FRIENDS BIRD

CUBIE 160

321100 white 'n' blue



CUBIE 160

321120 black 'n' red 'n' blue



With looks borrowed straight from CUBE's mountain bike range and a design tailored specially for young riders, the Cubie 160 is the ideal introduction to the joys of pedal power. Our engineers started with a geometry designed specifically around a child's needs, blending the fun of responsive handling with the safety of stable, predictable steering. Sturdy and lightweight 6061 aluminium tubes build into a structure that's tough enough to stand up to enthusiastic use, but light enough to inspire – and of course, smooth edges and corners wherever possible help minimise the risk of injury. Sensibly proportioned, child-friendly components are designed to last the course, so the rough and tumble of learning to ride won't result in broken dreams. The simplicity of a coaster rear brake, combined with a smooth rim brake controlled by a lever tailored for small hands at the front, means your child can learn how to control their speed as their confidence grows. We've fitted a new alloy crank and a Hebie Chainlooper to keep the transmission safely enclosed, CUBE tyres with lots of grip, a comfortable ride and the rugged looks of a full-size mountain bike, and a motocross-inspired rear mudguard. It's everything a future mountain bike rider could want.

-  **FRAME**#Alu Lite 6061
- SIZE**#6"
- FORK**#Rigid Hi-Ten fork

- HEADSET**#CUBE A-Headset
- STEM**#CUBE Alu Lite
- HANDLEBAR**#CUBE Alu Lite, 450mm
- GRIPS**#CUBE Kid Grips
- BRAKE SYSTEM**#Front: Alloy Cantilever; Rear: Coaster Brake
- CRANKSET**#amox, 25T, 114mm with Chainlooper
- CHAIN**#MC S1
- RIMS**#aluminium
- FRONT HUB**#CUBE Aluminium
- REAR HUB**#CUBE Aluminium
- TYRES**#CUBE IMPAC Streetpac
- PEDALS**#CUBE Kid
- SADDLE**#CUBE Kid
- SEAT POST**#CUBE Alu Lite
- SEATCLAMP**#CUBE
- BELL**#luvo

 **WEIGHT**#,5 kg



10991
CUBE JUNIOR BAGGY SHORTS



10990
CUBE JUNIOR TEAMLINE JERSEY



16263
CUBE HELMET FINK

-  **SPARE PARTS**#
- 13530** Inner Tube 16" JUNIOR/MTB AV 35 mm
- 13531** Inner Tube 16" JUNIOR/MTB DV 26 mm

CUBIE 180 SL

321500 red 'n' green 'n' black



CUBIE 180 SL

321510 lightblue 'n' red



The Cubie 180 SL brings the V-brake system of a real mountain bike to a perfectly proportioned, lightweight aluminium frame designed especially for budding little rippers. Our engineers know that kids may be small, but they're capable of giving a bike a really hard time simply through their enthusiasm and energy – as well as a few mistakes along the way. That's why they built the Cubie 180 SL's 6061 aluminium frame with the same attention to detail that we lavish on our full-size mountain bikes, so that it can take a few everyday knocks and scrapes in its stride. With features like the complex-profile down tube borrowed from our adult range, it really is a proper mountain bike in miniature form – and the components are carefully selected to provide a comfortable fit and perfect function for young riders. From wide, grippy and comfortable Schwalbe tyres to the brake levers designed for small hands, we've taken care of every detail. There are no gears to worry about, and the Hebie Chainlooper encloses the chain safely and keeps it away from your youngster's legs. It's every inch a real, no-compromise bike... just stripped down to the bare essentials.

 **FRAME** #Alu Lite 6061
SIZE #8"
FORK #Rigid Alloy fork

 **HEADSET** #CUBE A-Headset
STEM #CUBE Alu Lite
HANDLEBAR #CUBE Alu Lite, 450mm
GRIPS #CUBE Kid Grips
BRAKE SYSTEM #Alloy V-Brake With Powermodulator
CRANKSET #Prowheel, 25T, 89mm with Chainlooper
CHAIN #MC S1
RIMS #aluminium
FRONT HUB #CUBE Aluminium
REAR HUB #CUBE Aluminium
TYRES #Schwalbe Black Jack
PEDALS #CUBE Kid
SADDLE #CUBE Kid
SEAT POST #CUBE Alu Lite
SEATCLAMP #CUBE
BELL #luvo

 **WEIGHT** #2 kg

 **SPARE PARTS** #
10045 CUBE 2-piece V-Brake Shoes
14200 RFR Z1 Chain Narrow

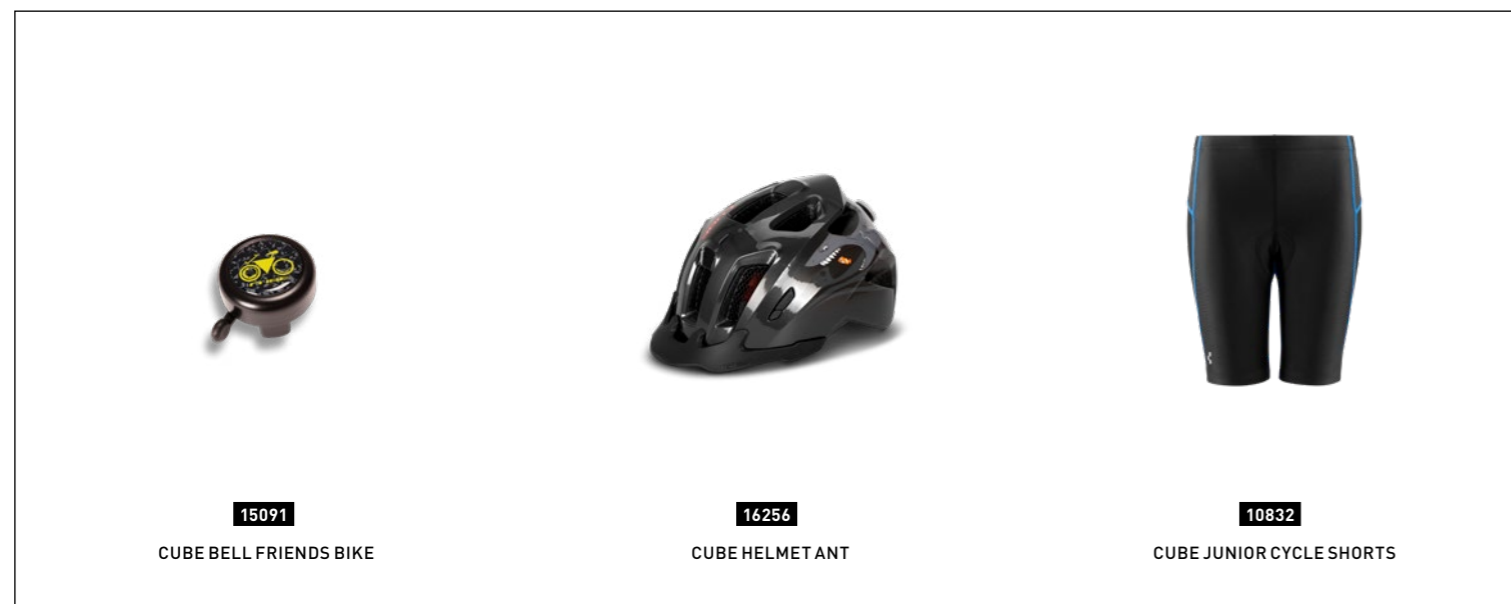

15091
CUBE BELL FRIENDS BIKE

16256
CUBE HELMET ANT

10832
CUBE JUNIOR CYCLE SHORTS

ACID 200

322120 kiwi'n'black'n'orange



ACID 200

322130 actionteam

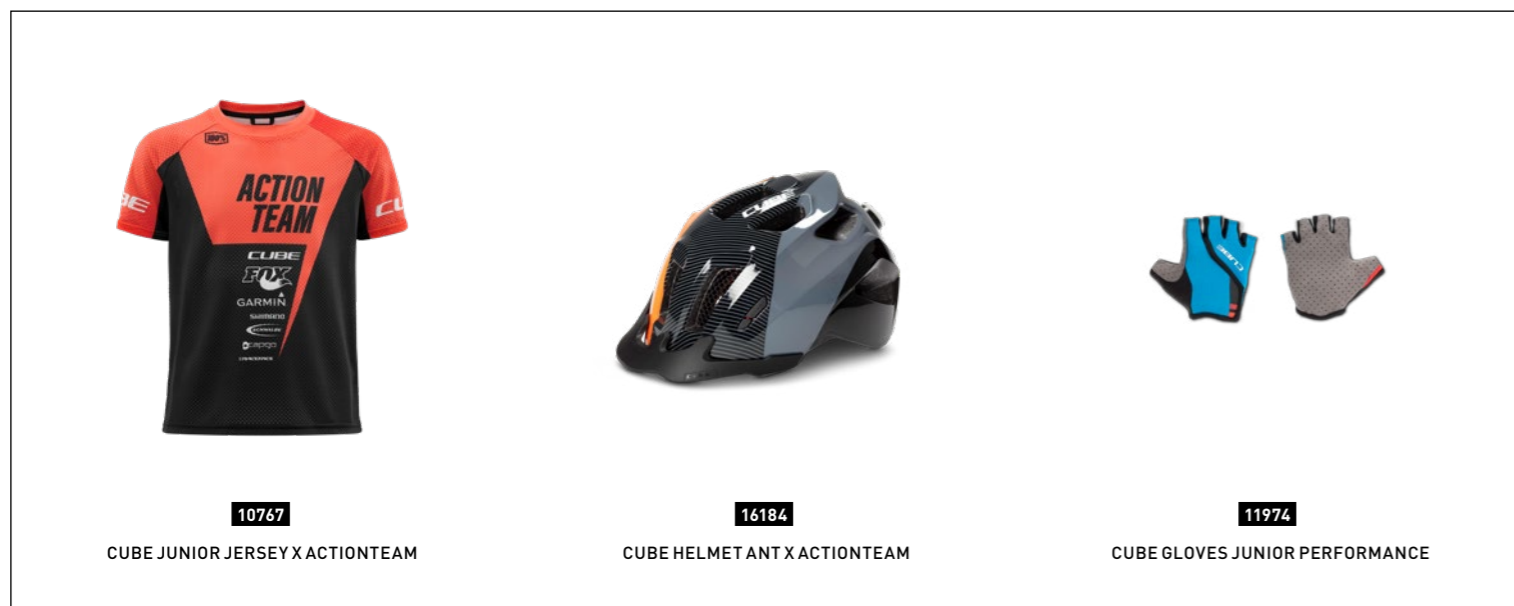



10767
CUBE JUNIOR JERSEY X ACTIONTEAM

16184
CUBE HELMET ANT X ACTIONTEAM

11974
CUBE GLOVES JUNIOR PERFORMANCE

Children get more adventurous as they get older – it's part of the natural process of growing up. And where their riding is concerned, that means they'll need a bike that's up to the task. The Acid 200 is every inch a junior version of its adult counterpart, from the carefully constructed frame to the 7-speed transmission and powerful, easily controllable brakes. Its heat-treated 6061 aluminium chassis has the same quality and durability as our full-size mountain bikes, but it's also as light as our engineers can reasonably make it whilst maintaining its strength. Because we know that accidents can happen when kids are pushing their limits, we've made the derailleur hanger easily replaceable so that a crash doesn't write off the frame. Details like the brake levers and alloy cranks are specially designed for small bodies, so they fit perfectly and work easily. There's even a power modulator on the front brake, so over-enthusiastic stopping is less likely to result in tears. And when the climb starts to get too steep, the large 34-tooth bailout gear will lend a helping hand for tired legs. Add it all up, and it's the ideal introduction to off-road fun with mum and dad.

-  **FRAME** #Alu Lite 6061
- SIZE** #20"
- FORK** #Rigid Hi-Ten fork

-  **HEADSET** #CUBE A-Headset
- STEM** #CUBE Alu Lite
- HANDLEBAR** #CUBE Alu Lite, 560mm
- GRIPS** #elo
- REAR DERAILLEUR** #Shimano RD-TY300, 7-Speed
- SHIFTERS** #Shimano SL-RS45, Revo Shift
- BRAKE SYSTEM** #Alloy V-Brake with Powermodulator
- CRANKSET** #Samox, 36T, 127mm with Chainguard, Alu
- CASSETTE** #Sunrace MFM300.7, 13-34T
- CHAIN** #MC HV500
- RIMS** #aluminium
- FRONT HUB** #CUBE Aluminium
- REAR HUB** #CUBE Aluminium
- TYRES** #CUBE IMPAC Smartpac
- PEDALS** #CUBE Kid
- SADDLE** #CUBE Kid
- SEAT POST** #CUBE Alu Lite
- SEATCLAMP** #CUBE
- BELL** #luvo

 **WEIGHT** #5 kg

-  **SPARE PARTS**
- 10146** CUBE Hanger #123
- 13532** Inner Tube 20" JUNIOR/MTB AV 35 mm
- 13533** Inner Tube 20" JUNIOR/MTB DV 40 mm

ACID 200

322140 grey'n'orange

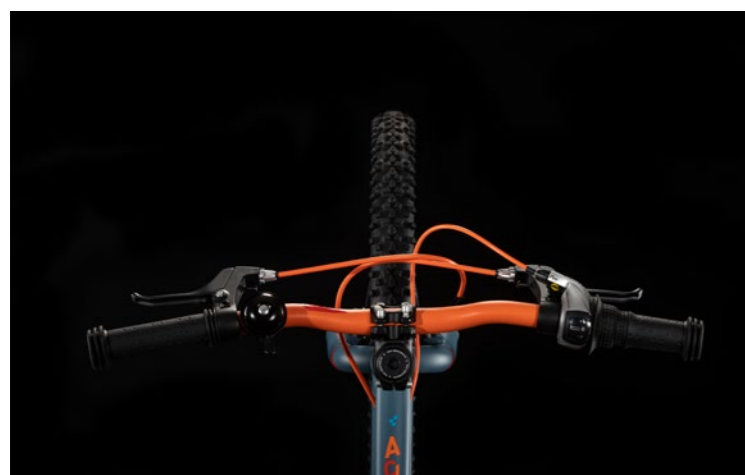

16273
CUBE HELMET LINOK X ACTIONTEAM



10780
CUBE JUNIOR JERSEY



11099
CUBE JUNIOR FREERIDE CAP X ACTIONTEAM

ACCESS 200

322150 white'n'blue'n'pink



Children get more adventurous as they get older – it's part of the natural process of growing up. And where their riding is concerned, that means they'll need a bike that's up to the task. The Acid 200 is every inch a junior version of its adult counterpart, from the carefully constructed frame to the 7-speed transmission and powerful, easily controllable brakes. Its heat-treated 6061 aluminium chassis has the same quality and durability as our full-size mountain bikes, but it's also as light as our engineers can reasonably make it whilst maintaining its strength. Because we know that accidents can happen when kids are pushing their limits, we've made the derailleur hanger easily replaceable so that a crash doesn't write off the frame. Details like the brake levers and alloy cranks are specially designed for small bodies, so they fit perfectly and work easily. There's even a power modulator on the front brake, so over-enthusiastic stopping is less likely to result in tears. And when the climb starts to get too steep, the large 34-tooth bailout gear will lend a helping hand for tired legs. Add it all up, and it's the ideal introduction to off-road fun with mum and dad.

 **FRAME**#Alu Lite 6061
SIZE#20"
FORK#Rigid Hi-Ten fork

 **HEADSET**#CUBE A-Headset
STEM#CUBE Alu Lite
HANDLEBAR#CUBE Alu Lite, 560mm
GRIPS#elo
REAR DERAILLEUR#Shimano RD-TY300, 7-Speed
SHIFTERS#Shimano SL-RS45, Revo Shift
BRAKE SYSTEM#Alloy V-Brake with Powermodulator
CRANKSET#Samox, 36T, 127mm with Chainguard, Alu
CASSETTE#Sunrace MFM300.7, 13-34T
CHAIN#MC HV500
RIMS#aluminium
FRONT HUB#CUBE Aluminium
REAR HUB#CUBE Aluminium
TYRES#CUBE IMPAC Smartpac
PEDALS#CUBE Kid
SADDLE#CUBE Kid
SEAT POST#CUBE Alu Lite
SEATCLAMP#CUBE
BELL#luvo

 **WEIGHT**#9 kg

 **SPARE PARTS#**
10146 CUBE Hanger #123
13532 Inner Tube 20" JUNIOR/MTB AV 35 mm
13533 Inner Tube 20" JUNIOR/MTB DV 40 mm

ACID 200 DISC

322170 black 'n' blue 'n' kiwi



You know what children are like – there's going to come a time when they want their bike to be just like mum and dad's. With the Acid 200 Disc, now they can. Featuring hydraulic disc brakes front and rear and an easy-shifting Shimano 7-speed gear setup, it's got everything the aspiring junior mountain biker could wish for. The heat-treated 6061 aluminium frame – with lightweight alloy fork – is crafted with the same attention to detail as our full-size bikes so that it's light, tough and handles beautifully. A replaceable derailleur hanger means that accidents don't need to mean a written-off frame, and brake levers designed for smaller hands ensure that your child can learn to control their speed safely. There's even a large 34-tooth bailout gear to provide some extra help for tired little legs on long or steep climbs. With grippy and comfortable CUBE tyres and a colour scheme that coordinates the frame, wheels and components, it's all your child needs to expand their horizons.

-  **FRAME** #Alu Lite 6061
- SIZE** #20"
- FORK** #Rigid Alloy fork

-  **HEADSET** #CUBE A-Headset
- STEM** #CUBE Alu Lite
- HANDLEBAR** #CUBE Alu Lite, 560mm
- GRIPS** #elo
- REAR DERAILLEUR** #Shimano RD-TY300, 7-Speed
- SHIFTERS** #Shimano SL-RS45, Revo Shift
- BRAKE SYSTEM** #ektro HD-M282, Hydr. Disc Brake (160/160)
- CRANKSET** #samox, 36T, 127mm with Chainguard, Alu
- CASSETTE** #Sunrace MFM300.7, 13-34T
- CHAIN** #MC HV500
- RIMS** #aluminium
- FRONT HUB** #CUBE Aluminium
- REAR HUB** #CUBE Aluminium
- TYRES** #CUBE IMPAC Smartpac
- PEDALS** #CUBE Kid
- SADDLE** #CUBE Kid
- SEAT POST** #CUBE Alu Lite
- SEATCLAMP** #CUBE
- BELL** #luvo

 **WEIGHT** #,9 kg

-  **SPARE PARTS** #
- 10146** CUBE Hanger #123
- 13532** Inner Tube 20" JUNIOR/MTB AV 35 mm
- 13533** Inner Tube 20" JUNIOR/MTB DV 40 mm



16258
CUBE HELMET ANT

11000
CUBE JUNIOR BAGGY SHORTS INCL. INNER SHORTS

10748
CUBE JUNIOR JERSEYS/S

ACID 200 SL

322180 red 'n' green 'n' black



ACID 200 SL

322190 turquoise 'n' white

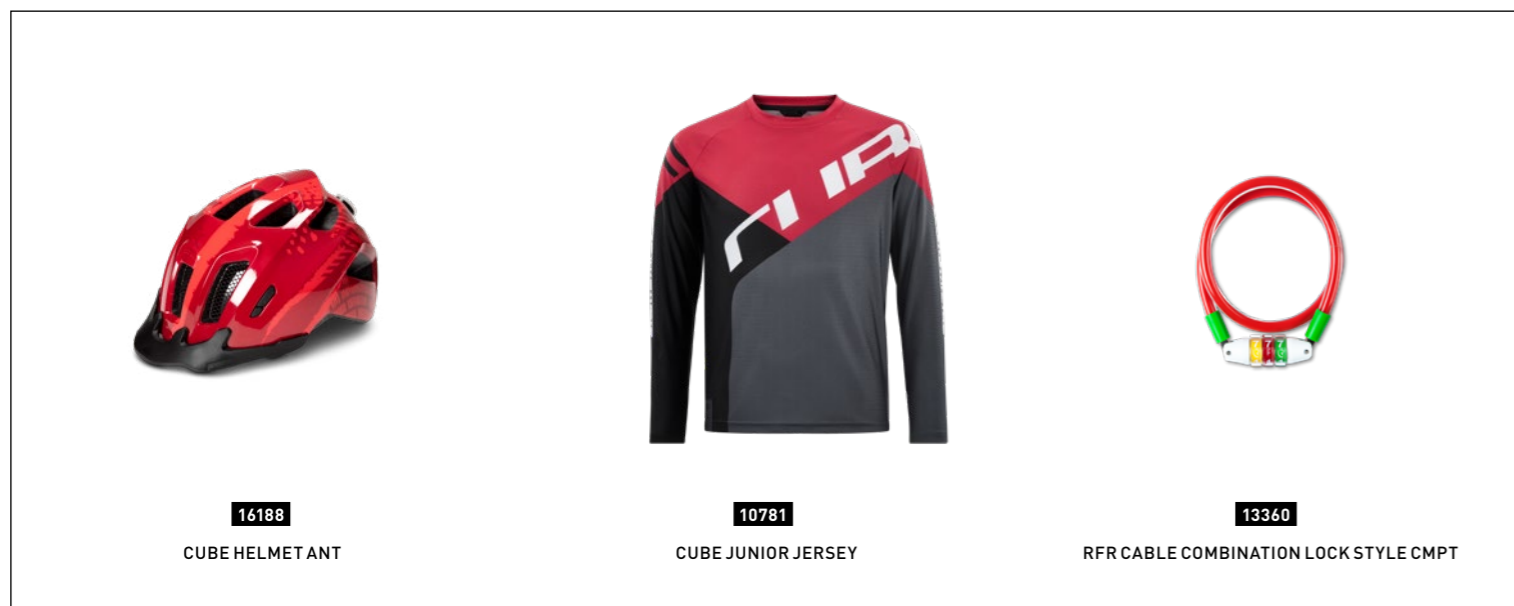
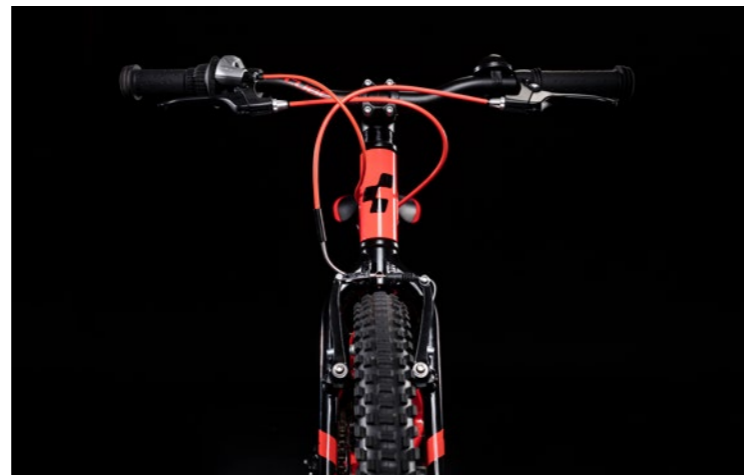

16188

CUBE HELMET ANT

10781

CUBE JUNIOR JERSEY

13360

RFR CABLE COMBINATION LOCK STYLE CMPT

Sometimes less really is more. The Acid 200 SL takes the same successful formula as the Acid 200 and trims what little fat there already was to result in an even lighter, livelier bike that your kids will love. The heat-treated 6061 aluminium frame – designed with the same attention to detail as our adult range for the ideal blend of low weight, optimum strength and safe handling – is matched with a lightweight alloy fork. We've shaved weight wherever possible, so it's livelier to ride than its competitors. The easy-shifting Shimano 7-speed transmission includes a 34-tooth bailout gear for a little help on those long, tough climbs – and we fitted a replaceable derailleur hanger to protect the frame in case of accidents. The brake levers are specially designed to work properly with smaller hands and there's a power modulator on the front brake too, so your child is always in control of their ride. And the brakes themselves? Simple, light and strong V-brakes for plenty of stopping power and super-easy maintenance and adjustment. Light, grippy and comfortable CUBE tyres – and a cool, radially-spoked front wheel – complete the package. It's everything your child needs, and nothing that she doesn't.



FRAME #Alu Lite 6061
SIZE #10"
FORK #Rigid Alloy fork



HEADSET #CUBE A-Headset
STEM #CUBE Alu Lite
HANDLEBAR #CUBE Alu Lite, 560mm
GRIPS #elo
REAR DERAILLEUR #Shimano RD-TY300, 7-Speed
SHIFTERS #Shimano SL-RS45, Revo Shift
BRAKE SYSTEM #Alloy V-Brake with Powermodulator
CRANKSET #Prowheel, 36T, 127mm with Chainguard, Alu
CASSETTE #Sunrace MFM300.7, 13-34T
CHAIN #MC HV500
RIMS #aluminium
FRONT HUB #CUBE Aluminium
REAR HUB #CUBE Aluminium
TYRES #Schwalbe Little Joe
PEDALS #CUBE Kid
SADDLE #CUBE Kid
SEAT POST #CUBE Alu Lite
SEATCLAMP #CUBE
BELL #luvo



WEIGHT #7 kg



SPARE PARTS

10146 CUBE Hanger #123
13532 Inner Tube 20" JUNIOR/MTB AV 35 mm
13533 Inner Tube 20" JUNIOR/MTB DV 40 mm

ACID 200 ALLROAD

322200 black 'n' yellow 'n' orange



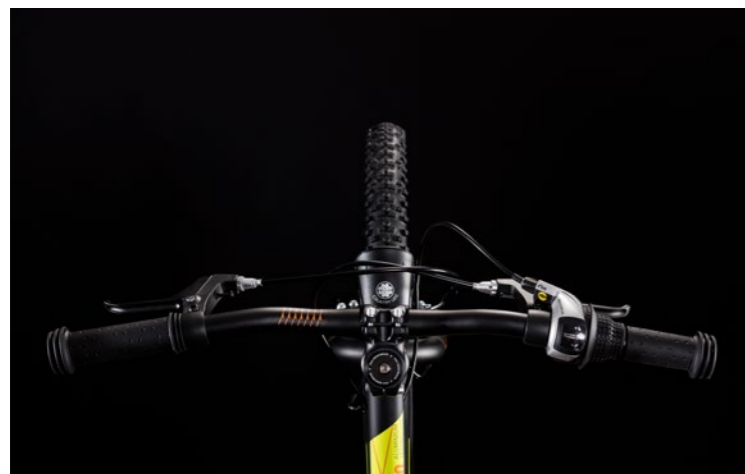

ACCESS 200 ALLROAD

322210 grey 'n' blue 'n' pink



Where can you find a roadworthy kid's bike that's also ideal for family trail rides? Our design team is one step ahead of you – allow us to introduce the Acid 200 Allroad. With all the cool factor of a real mountain bike, it also has all the safety features that parents want for peace of mind. The heat-treated 6061 aluminium frame benefits from the same attention to detail as all our bikes, so it's the ideal foundation on which to build your child's confidence and riding skills. With an easily replaceable gear hanger you can rest assured that little mishaps needn't result in expensive damage – perfect for an enthusiastic junior rider who's just finding their cycling feet. The child-specific V-brakes are specially adapted to work well with small hands and feature a power modulator on the front brake, to reduce the chance of a sudden handful resulting in an unscheduled dismount... and tears. Shimano's smooth-shifting 7-speed transmission has enough range to help tired legs up big hills and fresh legs speed down the other side. And then we added a pair of high-quality LED lights powered by a hub dynamo – which means there are no batteries to run out – and a pair of snap-on mudguards. It's everything your youngster needs to ride safely on road and off. There's no better introduction to the joys of exploring by bike...

-  **FRAME** #Alu Lite 6061
- SIZE** #20"
- FORK** #Rigid Hi-Ten fork

-  **HEADSET** #CUBE A-Headset
- STEM** #CUBE Alu Lite
- HANDLEBAR** #CUBE Alu Lite, 560mm
- GRIPS** #elo
- REAR DERAILLEUR** #Shimano RD-M300, 7-Speed
- SHIFTERS** #Shimano SL-RS45, Revo Shift
- BRAKE SYSTEM** #Alloy V-Brake with Powermodulator
- CRANKSET** #Samox, 36T, 127mm with Chainguard, Alu
- CASSETTE** #Sunrace MFM300.7, 13-34T
- CHAIN** #MC HV500
- RIMS** #aluminium
- FRONT HUB** #Shimano DH-C4001-1N
- REAR HUB** #CUBE Aluminium
- TYRES** #CUBE IMPAC Smartpac
- PEDALS** #CUBE Kid
- SADDLE** #CUBE Kid
- SEAT POST** #CUBE Alu Lite
- SEATCLAMP** #CUBE
- FRONT LIGHT** #Büchel Country LED
- REAR LIGHT** #relock Standlight
- KICKSTAND** #Center Kickstand, Adjustable
- MUDGUARDS** #Future Forms Snap on
- BELL** #luvo

 **WEIGHT** #0,8 kg

-  **SPARE PARTS** #
- 10146** CUBE Hanger #123
- 13532** Inner Tube 20" JUNIOR/MTB AV 35 mm
- 13533** Inner Tube 20" JUNIOR/MTB DV 40 mm



16262
CUBE HELMET FINK



13320
RFR CABLE LOCK HPS „DOG“ 10 X 450 MM



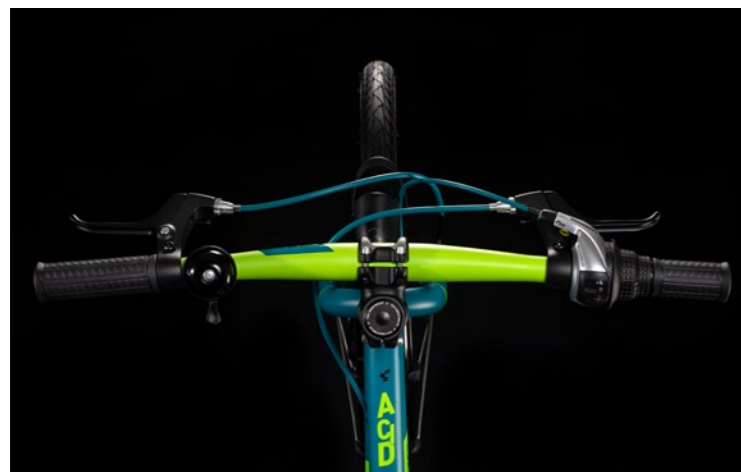

15089
CUBE BELL FRIENDS BIRD





Fun, safe and versatile – that’s our Kid 200 Street in a nutshell. Built to handle the rough-and-tumble of everyday use with the assurance of having passed our tough in-house safety tests, its light, durable, heat-treated 6061 aluminium frame is designed with the same care that we put into all our bikes. That’s why, for example, there’s a replaceable gear hanger – to reduce the chances of a mishap causing an expensive repair. But there’s more to this bike than the frame, because we’ve added smooth-rolling tyres and a host of practical add-on accessories to create a bike that’s perfect for adventurous young riders, wherever their curiosity takes them. The LED lighting system – driven from a hub dynamo, so you never have any worries about batteries running out – is permanently on and built to withstand any weather conditions, so young riders can always see and be seen. Brake levers designed for small hands make it easy to control the V-brakes, while a power modulator at the front helps prevent over-the-bars incidents caused by over-enthusiastic braking. Shimano’s 7-speed gear system is easy-to-use and reliable, giving little legs the range they need to tackle most hills. Carrying belongings is easy thanks to the included cargo rack, and full-length mudguards help keep clothes dry even when the weather isn’t cooperating. And the Kid 200 Street doesn’t even need a wall, tree or fence to stay upright, because we added a built-in kickstand. We reckon we thought of everything. All that’s missing is a young, keen rider.

-  **FRAME** #Alu Lite 6061
- SIZE** #0"
- FORK** #Rigid Hi-Ten fork

-  **HEADSET** #CUBE A-Headset
- STEM** #CUBE Alu Lite
- HANDLEBAR** #CUBE Alu Lite, 560mm
- GRIPS** #elo
- REAR DERAILLEUR** #Shimano RD-TY300, 7-Speed
- SHIFTERS** #Shimano SL-RS45 Revo Shift
- BRAKE SYSTEM** #Alloy V-Brake with Powermodulator
- CRANKSET** #Samox, 36T, 127mm with Chainguard, Alu
- CASSETTE** #Sunrace MFM300.7, 13-34T
- CHAIN** #MC HV500
- RIMS** #aluminium
- FRONT HUB** #Shimano DH-C3001-1N
- REAR HUB** #CUBE Aluminium
- TYRES** #CUBE IMPAC Streetpac
- PEDALS** #CUBE Kid
- SADDLE** #CUBE Kid
- SEAT POST** #CUBE Alu Lite
- SEATCLAMP** #CUBE
- FRONT LIGHT** #büchel Uni LED
- REAR LIGHT** #büchel Sunset Strip
- KICKSTAND** #Center Kickstand, Adjustable
- MUDGUARDS** #Future Forms
- BELL** #luvo

 **WEIGHT** #1,8 kg

-  **SPARE PARTS** #
- 13532** Inner Tube 20" JUNIOR/MTB AV 35 mm
- 13533** Inner Tube 20" JUNIOR/MTB DV 40 mm



16292
CUBE HELMET FINK



15093
CUBE BELL FRIENDS RABBIT



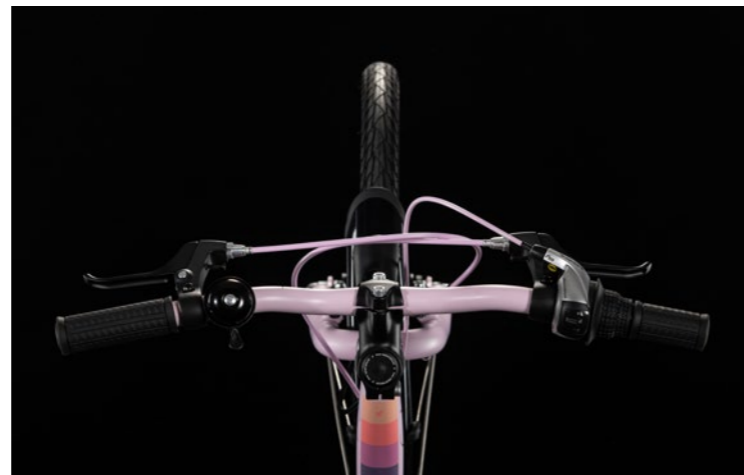

13355
RFR CABLE COMBINATION LOCK STYLE CMPT



Fun, safe and versatile – that’s our Ella 200 in a nutshell. Built to handle the rough-and-tumble of everyday use with the assurance of having passed our tough in-house safety tests, its light, durable, heat-treated 6061 aluminium frame is designed with the same care that we put into all our bikes. That’s why, for example, there’s a replaceable gear hanger – to reduce the chances of a mishap causing an expensive repair. But there’s more to this bike than the frame, because we’ve added smooth-rolling tyres and a host of practical add-on accessories to create a bike that’s perfect for adventurous young riders, wherever their curiosity takes them. The LED lighting system – driven from a hub dynamo, so you never have any worries about batteries running out – is permanently on and built to withstand any weather conditions, so young riders can always see and be seen. Brake levers designed for small hands make it easy to control the V-brakes, while a power modulator at the front helps prevent over-the-bars incidents caused by over-enthusiastic braking. Shimano’s 7-speed gear system is easy to use and reliable, giving little legs the range they need to tackle most hills. Carrying belongings is easy thanks to the included cargo rack, and full-length mudguards help keep clothes dry even when the weather isn’t cooperating. And the Ella 200 doesn’t even need a wall, tree or fence to stay upright, because we added a built-in kickstand. We reckon we thought of everything. All that’s missing is a young, keen rider.

-  **FRAME** #Cube Alu Lite 6061
- SIZE** #20"
- FORK** #Rigid Hi-Ten fork

-  **HEADSET** #Cube A-Headset
- STEM** #Cube Alu Lite
- HANDLEBAR** #Cube Alu Lite, 540mm
- GRIPS** #Velo
- REAR DERAILLEUR** #Shimano RD-TY300, 7-Speed
- SHIFTERS** #Shimano SL-RS45 Revo Shift
- BRAKE SYSTEM** #Alloy V-Brake with Powermodulator
- CRANKSET** #Samox, 36T, 127mm with Chainguard, Alu
- CASSETTE** #Sunrace MFM300.7, 13-34T
- CHAIN** #MC HV500
- RIMS** #Aluminium
- FRONT HUB** #Shimano DH-C3001-1N
- REAR HUB** #Cube Aluminium
- TYRES** #Cube IMPAC Streetpac
- PEDALS** #Cube Kid
- SADDLE** #Cube Kid
- SEAT POST** #Cube Alu Lite
- SEATCLAMP** #Cube
- FRONT LIGHT** #Büchel Uni LED
- REAR LIGHT** #Büchel Sunset Strip
- KICKSTAND** #Center Kickstand, Adjustable
- MUDGUARDS** #Future Forms
- BELL** #Luvo

 **WEIGHT** #1,9 kg

-  **SPARE PARTS** #
- 13532** Inner Tube 20" JUNIOR/MTB AV 35 mm
- 13533** Inner Tube 20" JUNIOR/MTB DV 40 mm



15089
CUBE BELL FRIENDS BIRD

13317
RFR CABLE COMBINATION LOCK HPS „CAT“

14257
CUBE HELMET ANT



Representing a halfway point between a kid's bike and a full-size adult's mountain bike, the Acid 240 is the ideal choice for growing riders who want to keep up with their friends and parents. That's because, when our engineers set out to design it, they began with the same heat-treated 6061 aluminium tubes that we use in our adult frames. The result is a frame that's every bit as durable as a full-size mountain bike, but with the right weight and proportions for a child. Mechanically formed tubes mean that it's bang up to date in terms of technology, too. The geometry is tailored to the needs of young riders, so it's stable and easily controllable with a low top tube to improve confidence and safety – and the replaceable gear hanger ensures that an accidental knock needn't result in an expensive repair. There's a Suntour suspension fork to improve comfort and control on rough surfaces, and Shimano 7-speed gears with Velo grip control bring every hill within reach. The V-brakes are powerful and easy to control, thanks to levers that are specially designed for small hands and a power modulator on the front. With a bike like this, there's nothing standing in the way of off-road adventures for your little riders...

FRAME #Alu Lite 6061
SIZE #4"
FORK #SR Suntour SF15

HEADSET #CUBE A-Headset
STEM #CUBE Alu Lite
HANDLEBAR #CUBE Alu Lite, 590mm
GRIPS #velo
REAR DERAILLEUR #Shimano RD-M310, 7-Speed
SHIFTERS #Shimano SL-RS45, Revo Shift
FRONT DERAILLEUR #Shimano FD-TY300
BRAKE SYSTEM #Alloy V-Brake with Powermodulator
CRANKSET #Frodo, 42x34x24T, 140mm with Chainguard
CASSETTE #Sunrace MFM300.7, 13-34T
CHAIN #MC HV500
RIMS #aluminium
FRONT HUB #CUBE Aluminium
REAR HUB #CUBE Aluminium
TYRES #CUBE IMPAC Smartpac
PEDALS #CUBE Kid
SADDLE #CUBE Kid
SEAT POST #CUBE Alu Lite
SEATCLAMP #CUBE
BELL #luvo

WEIGHT #1,9 kg

SPARE PARTS#
10146 CUBE Hanger #123
13534 Inner Tube 24" JUNIOR/MTB AV 35 mm
13535 Inner Tube 24" JUNIOR/MTB DV 40 mm

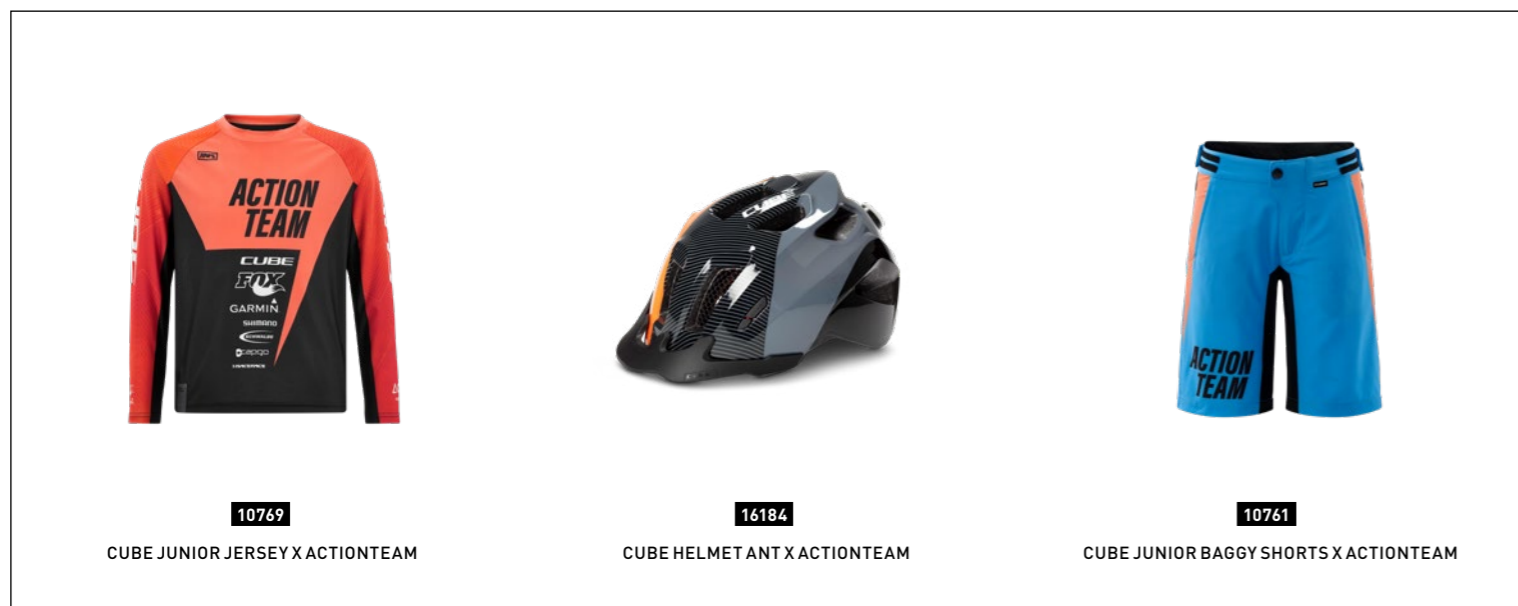

10769
 CUBE JUNIOR JERSEY X ACTIONTEAM

16184
 CUBE HELMET ANT X ACTIONTEAM

10761
 CUBE JUNIOR BAGGY SHORTS X ACTIONTEAM

ACID 240

323130 green'n'blue'n'grey

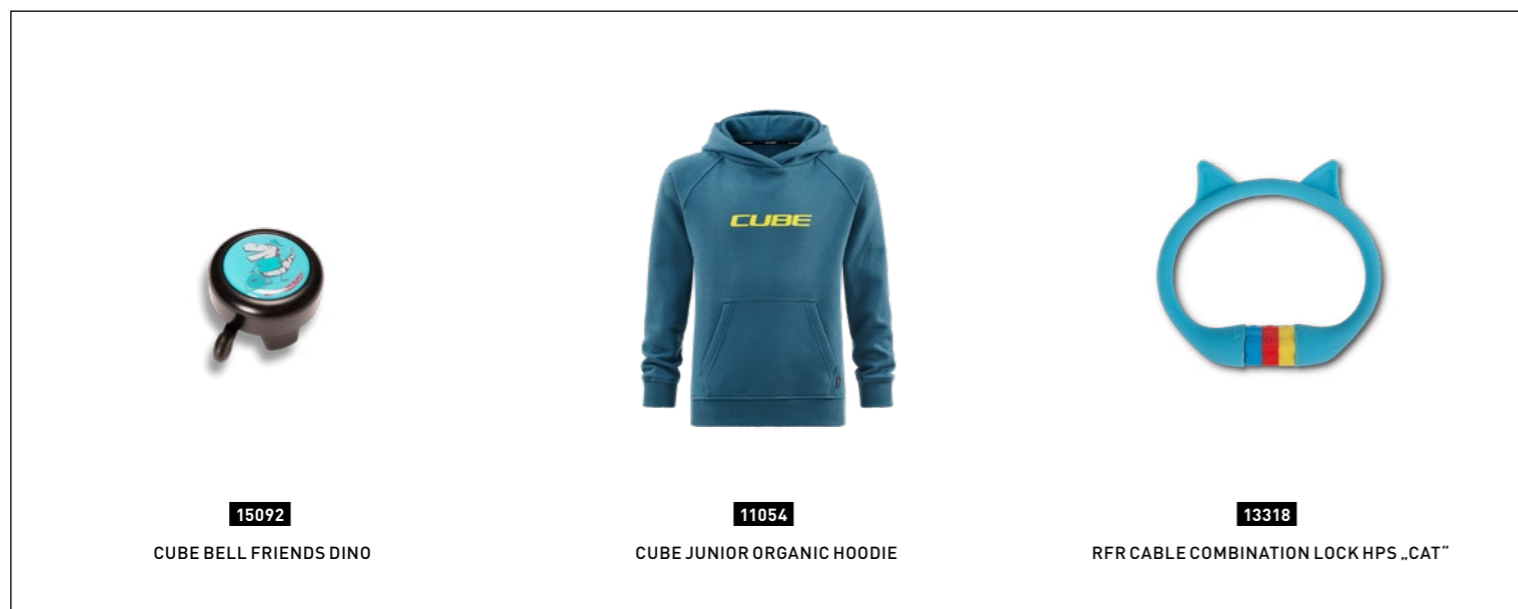

15092
CUBE BELL FRIENDS DINO

11054
CUBE JUNIOR ORGANIC HOODIE

13318
RFR CABLE COMBINATION LOCK HPS „CAT“

ACID 240

323120 green'n'lime



Representing a halfway point between a kid's bike and a full-size adult's mountain bike, the Acid 240 is the ideal choice for growing riders who want to keep up with their friends and parents. That's because, when our engineers set out to design it, they began with the same heat-treated 6061 aluminium tubes that we use in our adult frames. The result is a frame that's every bit as durable as a full-size mountain bike, but with the right weight and proportions for a child. Mechanically formed tubes mean that it's bang up to date in terms of technology, too. The geometry is tailored to the needs of young riders, so it's stable and easily controllable with a low top tube to improve confidence and safety – and the replaceable gear hanger ensures that an accidental knock needn't result in an expensive repair. There's a Suntour suspension fork to improve comfort and control on rough surfaces, and Shimano 7-speed gears with Velo grip control bring every hill within reach. The V-brakes are powerful and easy to control, thanks to levers that are specially designed for small hands and a power modulator on the front. With a bike like this, there's nothing standing in the way of off-road adventures for your little riders...

FRAME #Alu Lite 6061
SIZE #4"
FORK #R Suntour SF15

HEADSET #CUBE A-Headset
STEM #CUBE Alu Lite
HANDLEBAR #CUBE Alu Lite, 590mm
GRIPS #elo
REAR DERAILLEUR #Shimano RD-M310, 7-Speed
SHIFTERS #Shimano SL-RS45, Revo Shift
BRAKE SYSTEM #Alloy V-Brake with Powermodulator
CRANKSET #Samox, 32T, 152mm with Chainguard, Alu
CASSETTE #Sunrace MFM300.7, 13-34T
CHAIN #MC HV500
RIMS #aluminium
FRONT HUB #CUBE Aluminium
REAR HUB #CUBE Aluminium
TYRES #CUBE IMPAC Smartpac
PEDALS #CUBE Kid
SADDLE #CUBE Kid
SEAT POST #CUBE Alu Lite
SEATCLAMP #CUBE
BELL #luvo

WEIGHT #1,7 kg

SPARE PARTS
10146 CUBE Hanger #123
13534 Inner Tube 24" JUNIOR/MTB AV 35 mm
13535 Inner Tube 24" JUNIOR/MTB DV 40 mm



Representing a halfway point between a kid's bike and a full-size adult's mountain bike, the Access 240 is the ideal choice for growing riders who want to keep up with their friends and parents. That's because, when our engineers set out to design it, they began with the same heat-treated 6061 aluminium tubes that we use in our adult frames. The result is a frame that's every bit as durable as a full-size mountain bike, but with the right weight and proportions for a child. Mechanically formed tubes mean that it's bang up to date in terms of technology, too. The geometry is tailored to the needs of young riders, so it's stable and easily controllable with a low top tube to improve confidence and safety – and the replaceable gear hanger ensures that an accidental knock needn't result in an expensive repair. There's a Suntour suspension fork to improve comfort and control on rough surfaces, and Shimano 7-speed gears with Velo grip control bring every hill within reach. The V-brakes are powerful and easy to control, thanks to levers that are specially designed for small hands and a power modulator on the front. With a bike like this, there's nothing standing in the way of off-road adventures for your little riders...

FRAME #Alu Lite 6061
SIZE #4"
FORK #R Suntour SF15

HEADSET #CUBE A-Headset
STEM #CUBE Alu Lite
HANDLEBAR #CUBE Alu Lite, 580mm
GRIPS #elo
REAR DERAILLEUR #Shimano RD-M310, 7-Speed
SHIFTERS #Shimano SL-RS45, Revo Shift
BRAKE SYSTEM #Alloy V-Brake with Powermodulator
CRANKSET #rowheel, 32T, 140mm with Chainguard
CASSETTE #Sunrace MFM300.7, 13-34T
CHAIN #MC HV500
RIMS #aluminium
FRONT HUB #CUBE Aluminium
REAR HUB #CUBE Aluminium
TYRES #CUBE IMPAC Smartpac
PEDALS #CUBE Kid
SADDLE #CUBE Kid
SEAT POST #CUBE Alu Lite
SEATCLAMP #CUBE
BELL #luvo

WEIGHT #1,7 kg

SPARE PARTS
10123 CUBE Hanger #123
13534 Inner Tube 24" JUNIOR/MTB AV 35 mm
13535 Inner Tube 24" JUNIOR/MTB DV 40 mm

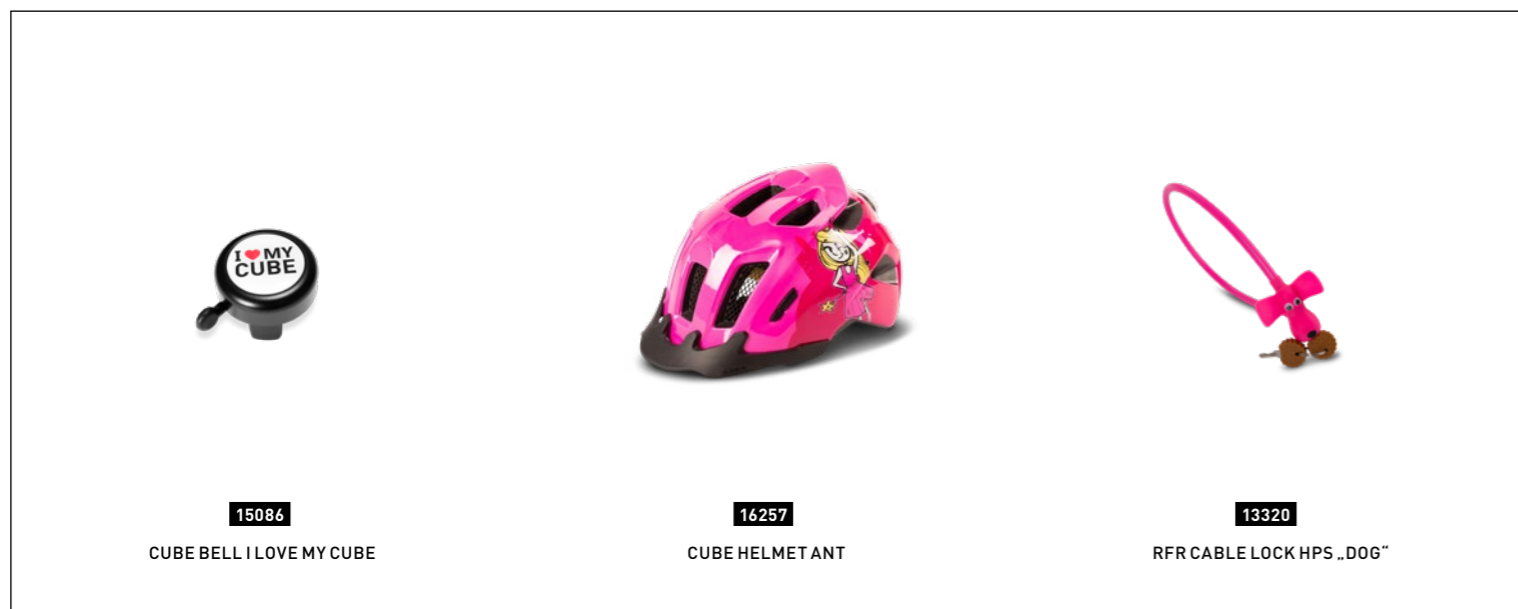

15086
 CUBE BELL I LOVE MY CUBE

16257
 CUBE HELMET ANT

13320
 RFR CABLE LOCK HPS „DOG“

ACID 240 DISC

323190 grey'n'neongreen



ACID 240 DISC

323200 reefblue'n'kiwi'n'red



The Acid 240 Disc is the bike that all youngsters will want. Light, strong and equipped with everything they'll need to help them keep up with their friends and family, it's got all the features you'll find on our adult mountain bikes. Hydraulic disc brakes are powerful and easy to control, with levers designed specifically for small hands. The Suntour suspension fork improves comfort and control on rough surfaces, and a wide-ranging 7-speed Shimano transmission gives a huge range of gears for tackling any terrain. From the heat-treated, mechanically formed 6061 aluminium tubes to the child-tailored geometry, our engineering team lavished the same attention to detail and perfectionist approach on this bike as they do on every bike they design. The low top tube improves confidence and safety, while a replaceable gear hanger makes the inevitable mishaps and knocks less costly. And, as you'd expect, the entire bike has passed our stringent in-house safety tests with flying colours. With a bike like this, there's nothing standing in the way of epic off-road adventures for the little mountain bikers in your family...

-  **FRAME** #Alu Lite 6061
- SIZE** #4"
- FORK** #R Suntour SF12 XCT JR, 50mm

- HEADSET** #CUBE A-Headset
- STEM** #CUBE Alu Lite
- HANDLEBAR** #CUBE Alu Lite, 580mm
- GRIPS** #elo
- REAR DERAILLEUR** #Shimano RD-M310, 7-Speed
- SHIFTERS** #Shimano SL-RS45, Revo Shift
- BRAKE SYSTEM** #ektro HDM-282, Hydr. Disc Brake (160/160)
- CRANKSET** #rowheel, 32T, 140mm with Chainguard
- CASSETTE** #Sunrace MFM300.7, 13-34T
- CHAIN** #MC HV500
- RIMS** #aluminium
- FRONT HUB** #CUBE Aluminium
- REAR HUB** #CUBE Aluminium
- TYRES** #CUBE IMPAC Smartpac
- PEDALS** #CUBE Kid
- SADDLE** #CUBE Kid
- SEAT POST** #CUBE Alu Lite
- SEATCLAMP** #CUBE
- BELL** #luvo

 **WEIGHT** #1,9 kg

-  **SPARE PARTS**
- 10146** CUBE Hanger #123
- 13534** Inner Tube 24" JUNIOR/MTB AV 35 mm
- 13535** Inner Tube 24" JUNIOR/MTB DV 40 mm



13355

RFR CABLE COMBINATION LOCK STYLE CMPT



16277

CUBE HELMET TALOK



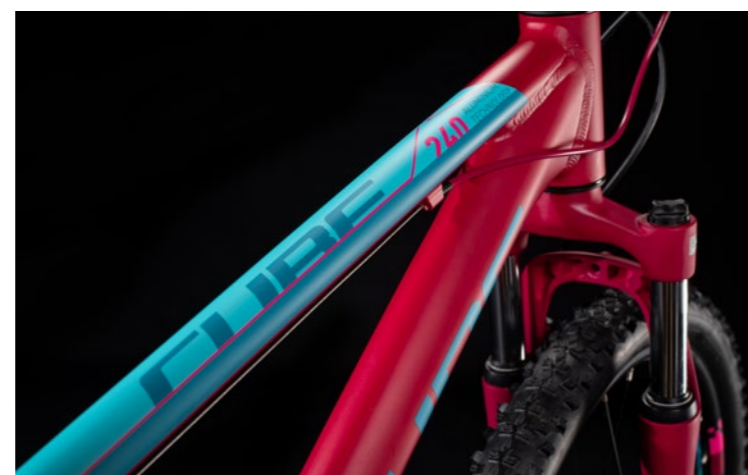
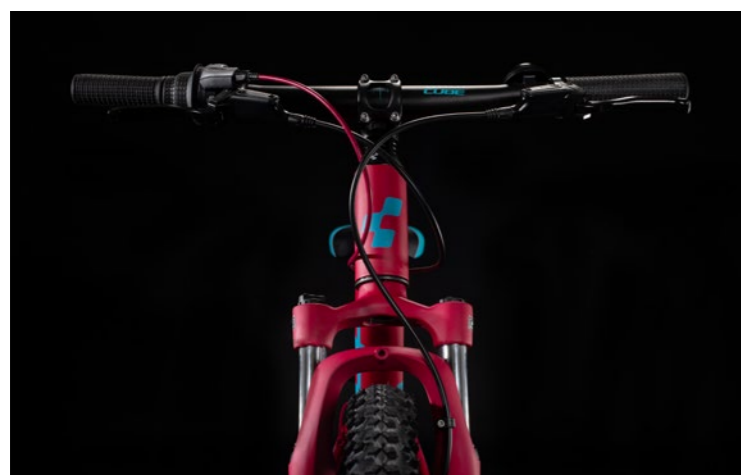

12802

CUBE BOTTLE CAGE HPP





The Access 240 Disc is the bike that all youngsters will want. Light, strong and equipped with everything they'll need to help them keep up with their friends and family, it's got all the features you'll find on our adult mountain bikes. Hydraulic disc brakes are powerful and easy to control, with levers designed specifically for small hands. The Suntour suspension fork improves comfort and control on rough surfaces, and a wide-ranging 7-speed Shimano transmission gives a huge range of gears for tackling any terrain. From the heat-treated, mechanically formed 6061 aluminium tubes to the child-tailored geometry, our engineering team lavished the same attention to detail and perfectionist approach on this bike as they do on every bike they design. The low top tube improves confidence and safety, while a replaceable gear hanger makes the inevitable mishaps and knocks less costly. And, as you'd expect, the entire bike has passed our stringent in-house safety tests with flying colours. With a bike like this, there's nothing standing in the way of epic off-road adventures for the little mountain bikers in your family...

-  **FRAME** #Alu Lite 6061
- SIZE** #4"
- FORK** #SR Suntour SF12 XCT JR, 50mm

-  **HEADSET** #CUBE A-Headset
- STEM** #CUBE Alu Lite
- HANDLEBAR** #CUBE Alu Lite, 580mm
- GRIPS** #elo
- REAR DERAILLEUR** #Shimano RD-M310, 7-Speed
- SHIFTERS** #Shimano SL-RS45, Revo Shift
- BRAKE SYSTEM** #ektro HDM-282, Hydr. Disc Brake (160/160)
- CRANKSET** #rowheel, 32T, 140mm with Chainguard
- CASSETTE** #Sunrace MFM300.7, 13-34T
- CHAIN** #MC HV500
- RIMS** #aluminium
- FRONT HUB** #CUBE Aluminium
- REAR HUB** #CUBE Aluminium
- TYRES** #CUBE IMPAC Smartpac
- PEDALS** #CUBE Kid
- SADDLE** #CUBE Kid
- SEAT POST** #CUBE Alu Lite
- SEATCLAMP** #CUBE
- BELL** #luvo

 **WEIGHT** #1,9 kg

-  **SPARE PARTS**
- 10146** CUBE Hanger #123
- 13534** Inner Tube 24" JUNIOR/MTB AV 35 mm
- 13535** Inner Tube 24" JUNIOR/MTB DV 40 mm



16274
CUBE HELMET LINOK



13099
CUBE FLASCHENHALTER HPP



13321
RFR CABLE LOCK HPS „DOG“

ACID 240 SL

323100 red 'n' green 'n' black



93052
ACID LIGHT SET PRO 30

11083
CUBE JUNIOR ORGANIC T-SHIRT MONSTER

14188
CUBE HELMET ANT

ACID 240 SL

323110 purple 'n' blue



Sometimes less can be more. With our Acid 240 SL we've created a kid's bike that's pared down to the essentials to make a light, strong and capable mountain bike for the junior riders in your family. When our engineers set out to design it, they began with the same heat-treated 6061 aluminium tubes that we use in our adult frames. The result is a frame that's every bit as durable as a full-size mountain bike, but with the right weight and proportions for a child. Mechanically formed tubes mean that it's bang up to date in terms of technology, too. The matching rigid alloy fork is lighter than a suspension fork and matches the frame's sleek looks, making a virtue out of simplicity. Geometry is tailored to the needs of young riders, so it's stable and easily controllable with a low top tube to improve confidence and safety – and the replaceable gear hanger ensures that a crash or knock needn't result in an expensive repair. Smooth-shifting Shimano 7-speed gears give your youngsters the range they need to keep up with the grown-ups, while powerful V-brakes – fitted with a power modulator at the front to minimise the risk of accidents – are equipped with brake levers especially designed for small hands. Schwalbe tyres have the grip needed to tackle any adventure and, of course, the whole lot is put together with the same fastidious attention to detail that we lavish on all our bikes.

-  **FRAME** #Alu Lite 6061
- SIZE** #4"
- FORK** #Rigid Alloy fork

-  **HEADSET** #CUBE A-Headset
- STEM** #CUBE Alu Lite
- HANDLEBAR** #CUBE Alu Lite, 590mm
- GRIPS** #elo
- REAR DERAILLEUR** #Shimano ARD-M310, 7-Speed
- SHIFTERS** #Shimano ASL RS45R7A
- BRAKE SYSTEM** #Alloy V-Brake with Powermodulator
- CRANKSET** #Alloy Crank, 32T, 140mm, with Chainguard
- CASSETTE** #Sunrace MFM300.7, 13-34T
- CHAIN** #MC HV500
- RIMS** #CUBE ACE17, 24H
- FRONT HUB** #CUBE Aluminium
- REAR HUB** #CUBE Aluminium
- TYRES** #Schwalbe Smart Sam, Folding
- PEDALS** #CUBE Kid
- SADDLE** #CUBE Kid
- SEAT POST** #CUBE Alu Lite
- SEATCLAMP** #CUBE
- BELL** #luvo

 **WEIGHT** #8 kg

-  **SPARE PARTS**
- 10146** CUBE Hanger #123
- 13534** Inner Tube 24" JUNIOR/MTB AV 35 mm
- 13535** Inner Tube 24" JUNIOR/MTB DV 40 mm

ACID 240 ALLROAD

323500 black 'n' blue 'n' green



ACCESS 240 ALLROAD

323510 grey 'n' blue 'n' pink



Should you have to modify a bike you've just bought for your child in order to make it safer on the road? No, we don't think so either. It's the reason we developed the Acid 240 Allroad – the kind of mountain bike that kids have always wanted, with the safety features that mean parents can relax. The package includes mudguards for wet weather, LED lights so that your child can see and be seen at any time of day, and a front brake modulator to prevent over-keen braking resulting in an over-the-bars accident. Brake levers are specially designed for the shorter reach of children's hands, and the Shimano 7-speed gears are easy to use. There's even a Suntour suspension fork for better comfort and control on rough surfaces. The frame onto which all this carefully selected equipment is bolted is equally impressive, boasting youth-specific geometry with a low top tube for the ideal blend of agility and stability. Heat-treated, mechanically formed 6061 aluminium frame tubes are of the same type that we use in our adult bikes, allowing our engineers to build a frame that easily passes our stringent in-house safety tests. Add it all up and it's everything that your young rider needs to conquer roads and trails, all on the same bike.

FRAME #Alu Lite 6061
SIZE #4"
FORK #SR Suntour SF15

HEADSET #CUBE A-Headset
STEM #CUBE Alu Lite
HANDLEBAR #CUBE Alu Lite, 580mm
GRIPS #elo
REAR DERAILLEUR #Shimano RD-M310, 7-Speed
SHIFTERS #Shimano SL-RS45 Revo Shift
BRAKE SYSTEM #Alloy V-Brake with Powermodulator
CRANKSET #Prowheel, 32T, 140mm with Chainguard
CASSETTE #Sunrace MFM300.7, 13-34T
CHAIN #MC HV500
RIMS #aluminium
FRONT HUB #Shimano DH-C4000-1N
REAR HUB #CUBE Aluminium
TYRES #CUBE IMPAC Smartpac
PEDALS #CUBE Kid
SADDLE #CUBE Kid
SEAT POST #CUBE Alu Lite
SEATCLAMP #CUBE
FRONT LIGHT #Büchel Country LED
REAR LIGHT #relock Standlight
KICKSTAND #center Kickstand, Adjustable
MUDGUARDS #Future Forms Snap on
BELL #luvo

WEIGHT #2,8 kg

SPARE PARTS
10146 CUBE Hanger #123
13534 Inner Tube 24" JUNIOR/MTB AV 35 mm
13535 Inner Tube 24" JUNIOR/MTB DV 40 mm



10991
CUBE JUNIOR BAGGY SHORTS



16258
CUBE HELMET ANT





10748
CUBE JUNIOR JERSEY



Safety for parents' peace of mind and fun for adventurous kids, all rolled into a single bike. Too good to be true? Not at all. Meet the Acid 240 Street – a road-safe kid's mountain bike that's as well suited to daily use as it is to occasional trail ride fun with the family at the weekends. Safety features include a dynamo-powered lighting system, so your child can see and be seen without any worry about running out of power. Added functionality comes courtesy of the included luggage carrier, mudguards and kickstand. And of course, the heat-treated 6061 aluminium frame goes through the same rigorous in-house testing process as our adult bikes, to ensure that it's more than strong and durable enough for the job. That gives you the peace of mind of knowing that your young rider is as safe as they can be on a bike that's been beautifully engineered. It also means it just rides better. Combined with the 21-speed Shimano gear system, Suntour suspension fork and powerful V-brakes, it adds up to performance that young riders will love and safety that parents will appreciate. At CUBE, we reckon you really can have your cake and eat it.

-  **FRAME**#Alu Lite 6061
- SIZE**#4"
- FORK**#SR Suntour SF15

-  **HEADSET**#CUBE A-Headset
- STEM**#CUBE Alu Lite
- HANDLEBAR**#CUBE Alu Lite, 590mm
- GRIPS**#elo
- REAR DERAILLEUR**#Shimano RD-M310, 7-Speed
- SHIFTERS**#Shimano SL-RS45 Revo Shift
- FRONT DERAILLEUR**#Shimano FD-TY500
- BRAKE SYSTEM**#Alloy V-Brake with Powermodulator
- CRANKSET**#Prowheel, 42x34x24T, 140mm with Chainguard
- CASSETTE**#Sunrace MFM300.7, 13-34T
- CHAIN**#MC HV500
- RIMS**#aluminium
- FRONT HUB**#Shimano DH-C4000-1N
- REAR HUB**#CUBE Aluminium
- TYRES**#CUBE IMPAC Tourpac
- PEDALS**#CUBE Kid
- SADDLE**#CUBE Kid
- SEAT POST**#CUBE Alu lite
- SEATCLAMP**#CUBE
- FRONT LIGHT**#Büchel Country LED
- REAR LIGHT**#Büchel Sunset Strip
- KICKSTAND**#Center Kickstand, Adjustable
- MUDGUARDS**#Future Forms
- BELL**#luvo

 **WEIGHT**#4,2 kg

-  **SPARE PARTS**
- 10146** CUBE Hanger #123
- 13534** Inner Tube 24" JUNIOR/MTB AV 35 mm
- 13535** Inner Tube 24" JUNIOR/MTB DV 40 mm



16276
CUBE HELMET TALOK

13360
RFR CABLE COMBINATION LOCK STYLE CMPT

13015
CUBE BOTTLE CAGE HPP



Safety for parents' peace of mind and fun for adventurous kids, all rolled into a single bike. Too good to be true? Not at all. Meet the Ella 240 – a road-safe kid's mountain bike that's as well suited to daily use as it is to occasional trail ride fun with the family at the weekends. Safety features include a dynamo-powered lighting system, so your child can see and be seen without any worry about running out of power. Added functionality comes courtesy of the included luggage carrier, mudguards and kickstand. And of course, the heat-treated 6061 aluminium frame goes through the same rigorous in-house testing process as our adult bikes, to ensure that it's more than strong and durable enough for the job. That gives you the peace of mind of knowing that your young rider is as safe as they can be on a bike that's been beautifully engineered. It also means it just rides better. Combined with the 21-speed Shimano gear system, Suntour suspension fork and powerful V-brakes, it adds up to performance that young riders will love and safety that parents will appreciate. At CUBE, we reckon you really can have your cake and eat it.

-  **FRAME**#Alu Lite 6061
- SIZE**#4"
- FORK**#Rigid Hi-Ten fork

-  **HEADSET**#CUBE A-Headset
- STEM**#CUBE Alu Lite
- HANDLEBAR**#CUBE Alu Lite, 580mm
- GRIPS**#elo
- REAR DERAILLEUR**#Shimano RD-M310, 7-Speed
- SHIFTERS**#Shimano SL-RS45 Revo Shift
- FRONT DERAILLEUR**#Shimano FD-TY500
- BRAKE SYSTEM**#Alloy V-Brake with Powermodulator
- CRANKSET**#Prowheel, 42x34x24T, 140mm with Chainguard
- CASSETTE**#Surnace MFM300.7, 13-34T
- CHAIN**#MC HV500
- RIMS**#aluminium
- FRONT HUB**#Shimano DH-C4000-1N
- REAR HUB**#CUBE Aluminium
- TYRES**#CUBE IMPAC Tourpac
- PEDALS**#CUBE Kid
- SADDLE**#CUBE Kid
- SEAT POST**#CUBE Alu Lite
- SEATCLAMP**#CUBE
- FRONT LIGHT**#Büchel Country LED
- REAR LIGHT**#Büchel Sunset Strip
- KICKSTAND**#Center Kickstand, Adjustable
- MUDGUARDS**#Future Forms
- BELL**#luvo

 **WEIGHT**#3,7 kg

-  **SPARE PARTS**#
- 13534** Inner Tube 24" JUNIOR/MTB AV 35 mm
- 13535** Inner Tube 24" JUNIOR/MTB DV 40 mm



16263
CUBE HELMET FINK

13318
RFR CABLE COMBINATION LOCK HPS „CAT“

15092
CUBE BELL FRIENDS DINO

FOR us #Pioneers

We don't believe in cutting corners at CUBE. It's the reason that our junior frames use the same kind of heat-treated 6061 aluminium tubes that you'll find in our adult bikes, as well as the same mechanical tube forming process to adjust tube shapes for the best combination of strength and weight. A low top tube – and geometry tailored to provide a blend of confidence-inspiring stability and fun-enhancing rigidity – work together to make the Reaction 240 SL both zippy and safe. Your child will love it and you will too, safe in the knowledge that we've sweated the details. A replaceable derailleur hanger means that little accidents needn't result in a large repair bill, and our engineering team made room for wide tyres for the best in grip, comfort and safety.



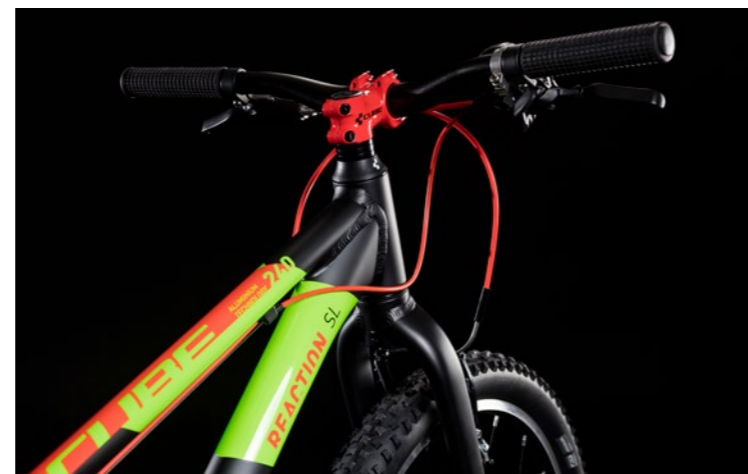

REACTION 240 SL

323300 red 'n' green 'n' black



Light, strong, simple, versatile... and perfectly proportioned for a keen young rider to get the best from it. That's the Reaction 240 SL, our no-compromise junior hardtail built with aspiring racers in mind. Featuring a heat-treated 6061 aluminium frame and matching lightweight aluminium rigid fork, our design team took a minimalist approach to build the lightest, most reliable and most capable kid's mountain bike they could imagine. Mechanical tube forming allowed our engineers to tailor tube shapes for the best combination of strength and weight, whilst a low top tube – and geometry tailored to provide a blend of confidence-inspiring stability and fun-enhancing agility – work together to make the Reaction 240 SL both fun and safe. The powerful V-brakes are easy to control thanks to levers designed for small hands, and a power modulator on the front brake reduces the risk of an unscheduled over-the-bars dismount caused by over-enthusiastic braking. Shimano's slick-shifting SLX 11-speed gears cover an enormous range, putting even the steepest of climbs within reach of a determined youngster. And big-volume, super lightweight folding Schwalbe tyres offer loads of grip and comfort for confidence-inspiring handling in the dirt, whilst wheels with a reduced spoke count save even more weight. Your child will love it and you will too, safe in the knowledge that we've sweated all the details.

-  **FRAME** #CUBE Alu Lite 6061
 - SIZE** #4"
 - FORK** #Rigid Alloy Fork
-
-  **HEADSET** #CUBE A-Headset
 - STEM** #CUBE Alu Lite
 - HANDLEBAR** #CUBE Alu Lite, 560mm, 25mm Rise
 - GRIPS** #elo
 - REAR DERAILLEUR** #Shimano SLX RD-M7000, 11-Speed
 - SHIFTERS** #Shimano SLX SL-M7000
 - BRAKE SYSTEM** #Alloy V-Brake with Powermodulator
 - CRANKSET** #CUBE Crankset, 32T, 152mm, with Chainguard, Token BB
 - CASSETTE** #Sunrace CSMS8, 11-42T
 - CHAIN** #MC X11
 - RIMS** #CUBE ACE17, Alloy Nipples
 - FRONT HUB** #CUBE Aluminium
 - REAR HUB** #CUBE Aluminium
 - TYRES** #Schwalbe Rocket Ron 2.1, Folding
 - PEDALS** #CUBE Kid
 - SADDLE** #CUBE Kid
 - SEAT POST** #CUBE Alu Lite
 - SEATCLAMP** #CUBE
 - BELL** #luvo

 **WEIGHT** #,8 kg

-  **SPARE PARTS** #
- 10146** CUBE Hanger #123
- 13536** Inner Tube 24" JUNIOR/MTB SV 40 mm



12802
CUBE BOTTLE CAGE HPP



14139
RFR PEDALS FLAT ETP



16277
CUBE HELMET TALOK

REACTION 240 TM

323400 black'n'orange



If there's an aspiring young mountain biker in your family, chances are they're already pushing their boundaries. The Reaction 240 TM will be right there with them, building their skills and confidence as they get faster and bolder out on the trails. Shimano's 1x11 SLX transmission provides a simple, reliable and incredibly wide-ranging choice of gears via its 11-46 tooth cassette, putting the right gear selection for any trail situation a click or two away. Powerful hydraulic disc brakes add easily controllable, all-weather stopping ability, and we selected a Suntour air-sprung suspension fork with 70mm of travel, rebound adjustment and a lighter negative spring specifically designed for lighter riders. It's easy to set up and offers noticeably improved comfort, grip and control. Schwalbe's Smart Sam 2.35in tyres add confidence-inspiring grip and comfort. And, of course, the frame is designed with the same devotion and fanatical attention to detail that our engineering team puts into every CUBE chassis. From its heat-treated, mechanically formed 6061 aluminium tubes to the child-focussed geometry, it's the perfect foundation for a trail-shredding junior explorer. It's ready to rock...



FRAME #CUBE Alu Lite 6061
SIZE #4"
FORK #SR Suntour Raidon LO-R, 70mm



HEADSET #CUBE A-Headset
STEM #CUBE Alu Lite
HANDLEBAR #CUBE Alu Lite, 560mm, 25mm Rise
GRIPS #elo
REAR DERAILLEUR #Shimano SLX RD-M7000-GS, Shadow, 11-Speed
SHIFTERS #Shimano SLX SL-M7000
BRAKE SYSTEM #ektro HDM-282, Hydr. Disc Brake (160/160)
CRANKSET #CUBE Crankset, 32T, 152mm, with Chainguard
CASSETTE #Sunrace CSMS8, 11-46T
CHAIN #MC X11
RIMS #CUBE DP23, 28H, Disc, Tubeless Ready, Alloy Nipples
FRONT HUB #CUBE Aluminium
REAR HUB #CUBE Aluminium
TYRES #Schwalbe Smart Sam 2.35, Folding
PEDALS #CUBE Kid
SADDLE #DG 19 Fly Jr.
SEAT POST #CUBE Alu Lite
SEATCLAMP #CUBE
BELL #luvo



WEIGHT #1,3 kg



SPARE PARTS
10146 CUBE Hanger #123
13536 Inner Tube 24" JUNIOR/MTB SV 40 mm

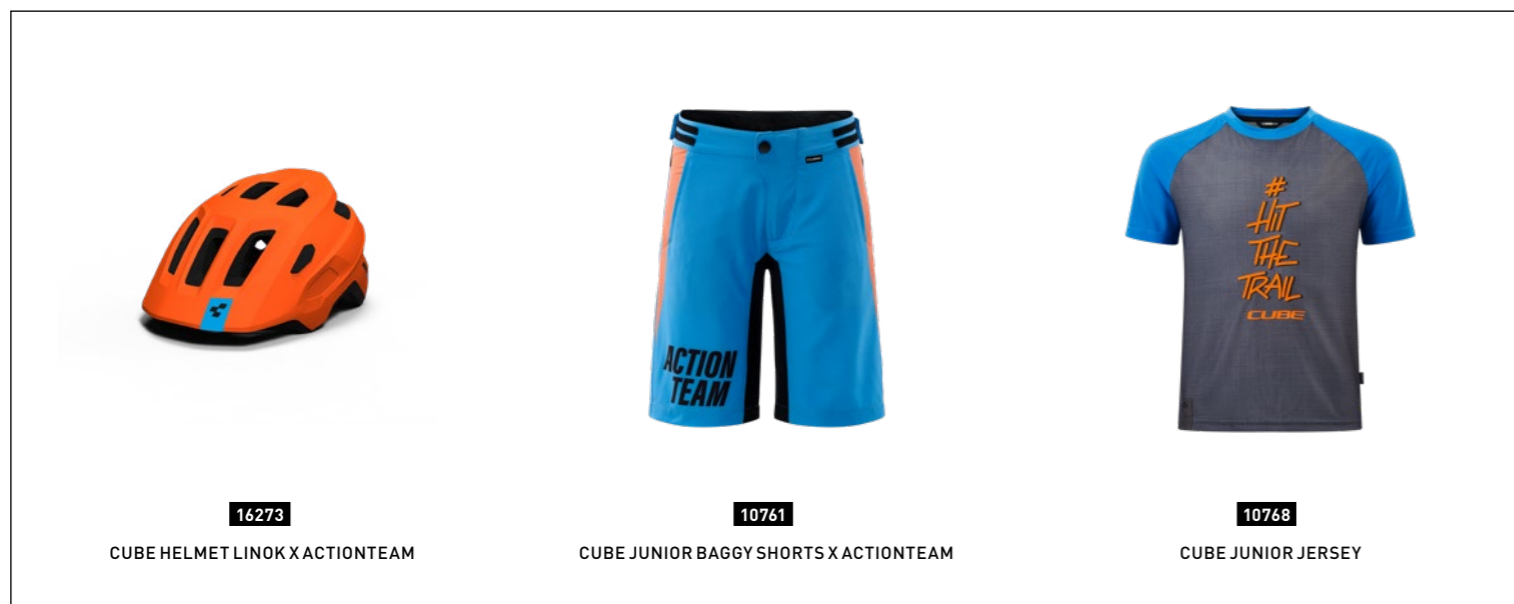

16273
 CUBE HELMET LINOK X ACTIONTEAM

10761
 CUBE JUNIOR BAGGY SHORTS X ACTIONTEAM

10748
 CUBE JUNIOR JERSEY

ACID 260

323700 black 'n' yellow



ACID 260

323710 blue 'n' red



Keen young riders will benefit from a bike that fits their needs – literally. The new Acid 260 borrows heavily from our adult hardtail range to create a 26in-wheeled bike with a low standover for confidence and safety. It uses the same mechanical tube forming process as our full-size bikes and, as you'd expect, the 6061 aluminium chassis has passed all our in-house tests to ensure it's strong, durable and safe in the hands of your youngsters. Internal cable routing reduces clutter and maintenance, and there's an integrated kickstand mount so you can add this handy extra without ruining the bike's clean looks. The Suntour XCT suspension fork has 80mm of bump-absorbing travel for rough trails, and the 24-speed Shimano gears cover a wide range to put every climb within reach. Light, powerful and easy to adjust V-brakes keep it all in control, and grippy tyres help keep the rubber side down. It's every inch a proper mountain bike, for your proper little mountain biker.

-  **FRAME** #CUBE Alu Lite 6061
- SIZE** #6"
- FORK** #R Suntour SF18 XCE, 80mm

- HEADSET** #CUBE A-Headset
- STEM** #CUBE Alu Lite
- HANDLEBAR** #CUBE Alu Lite, 660mm
- GRIPS** #CUBE Grips
- REAR DERAILLEUR** #Shimano RD-TX800, 8-Speed
- SHIFTERS** #Shimano ST-TX800
- FRONT DERAILLEUR** #Shimano FD-TY700
- BRAKE SYSTEM** #Alloy V-Brake with Powermodulator
- CRANKSET** #Shimano FC-TY301, 42x34x24, 170mm
- CASSETTE** #Shimano CS-HG200, 13-32T
- CHAIN** #MC CU8.3
- RIMS** #CUBE ACE17,
- FRONT HUB** #CUBE Aluminium
- REAR HUB** #CUBE Aluminium
- TYRES** #CUBE IMPAC Smartpac 26x2.1
- PEDALS** #CUBE Kid
- SADDLE** #CUBE Kid
- SEAT POST** #CUBE Alu Lite, 27,2 x 300mm
- SEATCLAMP** #CUBE

 **WEIGHT** #3,6 kg

- SPARE PARTS**
-  **10148** CUBE Hanger #148 short version
- 13537** Inner Tube 26" MTB AGV 40 mm
- 13539** Inner Tube 26" MTB DV 40 mm

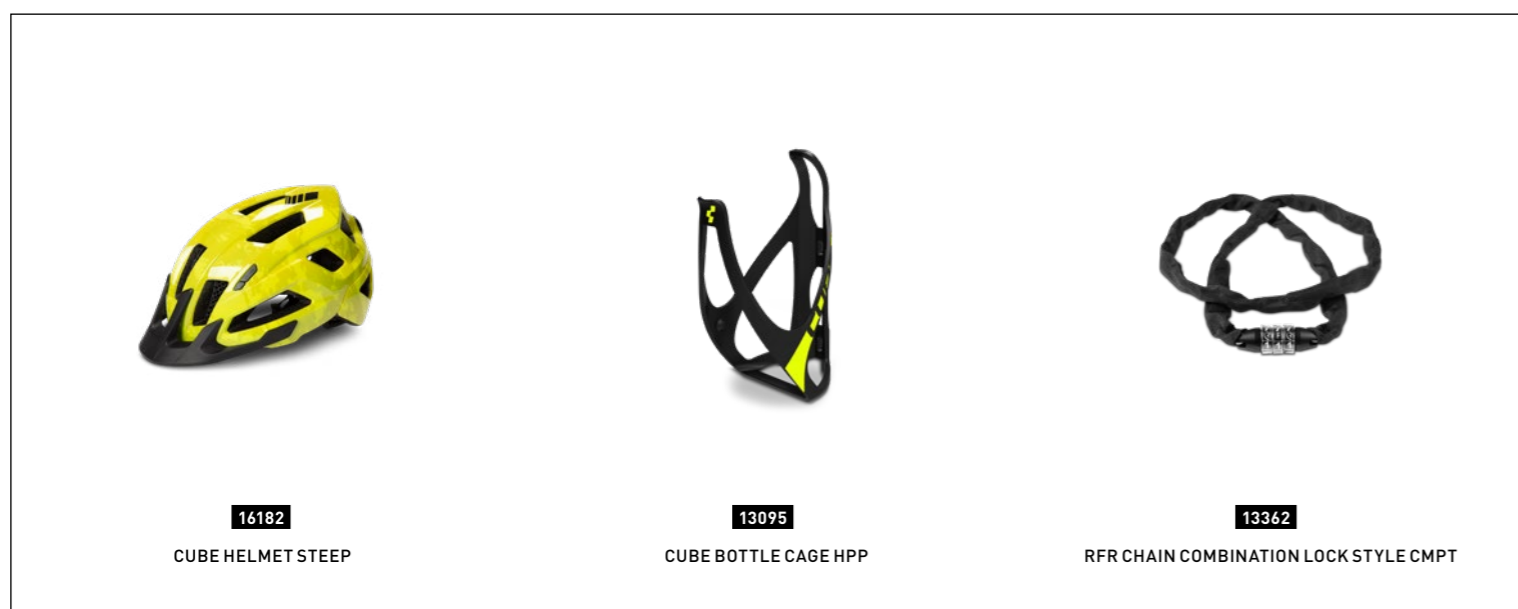

16182

CUBE HELMET STEEP

13095

CUBE BOTTLE CAGE HPP

13362

RFR CHAIN COMBINATION LOCK STYLE CMPT

ACID 260 DISC

323750 green'n'blue



ACID 260 DISC

323760 mint'n'blue



It may be an unusual approach, but we treat the design of our kid's bikes every bit as seriously as we do our adult range. That's why the Acid 260 Disc features the same mechanically formed 6061 aluminium tubes as our full-size Acid hardtails, but built around smaller 26in wheels and an 80mm suspension fork for the best possible standover height. Lower standover is important for young riders, since it helps boost confidence – and it's safer, too. We fitted Tektro hydraulic disc brakes for strong, dependable all-weather stopping ability and Shimano 3x8 gears for their reliable performance and wide range. Internal cable routing looks great and keeps gear shifts clean and crisp with the minimum of maintenance, whilst an integrated kickstand mount means you can easily add this useful accessory. We've thoroughly tested every aspect of the Acid 260 Disc in our in-house lab, so you can be sure it's more than strong and durable enough to withstand lots of enthusiastic use. And the Suntour suspension fork is the finishing touch that your kids will love, matching mum and dad's bike and adding a useful dose of extra comfort and control. Feed their curiosity and enthusiasm with a bike that's up to the task...

FRAME #Alu Lite 6061
SIZE #6"
FORK #SR Suntour SF18 XCE, 80mm

HEADSET #CUBE A-Headset
STEM #CUBE Alu Lite
HANDLEBAR #CUBE Alu Lite, 660mm
GRIPS #CUBE Grips
REAR DERAILLEUR #Shimano RD-M360, 8-Speed
SHIFTERS #Shimano SL-M315
FRONT DERAILLEUR #Shimano FD-TY700
BRAKE SYSTEM #Tektro HD-M276, Hydr. Disc Brake (160/160)
CRANKSET #Shimano FC-TY301, 42x34x24, 170mm
CASSETTE #Shimano CS-HG200, 13-32T
CHAIN #MC CU8.3
RIMS #CUBE SD20,
FRONT HUB #CUBE Aluminium
REAR HUB #CUBE Aluminium
TYRES #CUBE IMPAC Smartpac 26x2.1
PEDALS #CUBE Kid
SADDLE #CUBE Kid
SEAT POST #CUBE Alu Lite, 27,2 x 300mm
SEATCLAMP #CUBE

WEIGHT #3,9 kg

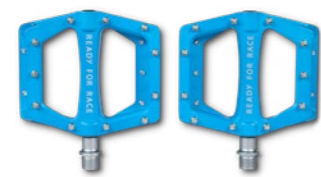

14141

RFR PEDALS FLAT CMPT



16229

CUBE HELMET DIRT 2.0



13851

RFR POWER LIGHT 300 USB „WHITE“

SPARE PARTS
10148 CUBE Hanger #148 short version
13537 Inner Tube 26" MTB AGV 40 mm
13539 Inner Tube 26" MTB DV 40 mm



FOR us #YoungGuns

Small, but perfectly formed: that's the Reaction C:62 Youth. Boasting the same frame features and attention to detail as our full-size Reaction C:62 frames, it's the light, stiff and responsive frame that'll make the most of your young racer's energy and enthusiasm. The tapered head tube, short rear end and stiff chain stays ensure that every single watt expended at the pedals goes towards propelling the bike forwards, but slim seat stays and a narrow 27.2mm seat post work with carbon's natural vibration-damping properties to deliver a ride that's surprisingly comfortable, too. Internal cable routing keeps gears shifting cleanly and reliably through the worst trail and weather conditions – and dad won't have to spend his time fiddling with adjustments. It's a full-blown junior racer, and it should give your own junior racer all the excuse they need to pedal their heart out... and have fun.





If your junior mountain biker has caught the racing bug, they'll need a bike to make the most of their evolving skills and fitness. That's why we built the Reaction C:62 Youth – a light, fast, carbon-framed hardtail built to the same standards as our adult race bikes. Crafted from our premium C:62 carbon using our Advanced Twin Mold process, it boasts exactly the same features you'd expect to see on a World Cup athlete's bike. The tapered head tube and 12mm thru rear axle combine to create a stiff, precise frame. At the same time, slender seat stays and a narrow 27.2mm seat post make the most of carbon's inherent vibration-damping properties to improve comfort. The result is a bike that's as fast as it is good-looking – so, of course, we needed to give it the best components. The air-sprung Manitou Markhor fork works with wide, grippy Schwalbe tyres to deliver impeccable comfort and control, while Sram's NX Eagle drivetrain serves up 12 wide-ranging, perfectly-spaced gears for tackling even the toughest of tracks. Answer Attack MA rims are light enough for racing but tough enough to stay the course, and Magura MT4 hydraulic disc brakes offer fantastic stopping power in all weathers. All that's needed for a podium finish is a keen young rider with the will to win...

FRAME#C:62 Monocoque Advanced Twin Mold Technology, ARG2, Tapered Headtube, PressFit Boost BB, Integrated Cable Routing, Boost 148, Dropper Post Ready
SIZE#Size Split: 27.5: 13,5" // 29: 15"
FORK#Manitou Markhor TS Air, Tapered, 100mm, Remote Lockout

HEADSET#SA Orbit I-t, Integrated, Top 1 1/8", Bottom 1 1/2"
STEM#Newmen Evolution 318.4, 31.8mm
HANDLEBAR#CUBE Flat Race Bar, 660mm
GRIPS#CUBE Race SL Grip 29.5mm, 1-Clamp
REAR DERAILLEUR#Sram NX Eagle™, 12-Speed
SHIFTERS#Sram NX Eagle™ Trigger
BRAKE SYSTEM#Magura MT4, Hydr. Disc Brake (180/160)
CRANKSET#Sram Stylo Eagle™, 32T, Boost, 170mm
CASSETTE#Sram XG-1230, 11-50T
CHAIN#Sram NX Eagle™
WHEELSET#Answer Attack MA, 28/28 Spokes, QR/12x148mm, Tubeless Ready
TYRES#Schwalbe Rocket Ron, Addix Speed, Kevlar, 2.10, LiteSkin
SADDLE#Natural Fit Venec
SEAT POST#CUBE Prolight, 27.2mm
SEATCLAMP#CUBE Varioclose, 31.8mm

WEIGHT#,9 kg

SPARE PARTS#
8651 CUBE HANGER_mtb-x12-std-2020 (18-05516)
10339 CUBE Headset Orbit I-T + 1 1/8 crown race
13457 RFR Seatclamp with Quick Release 34,9 mm

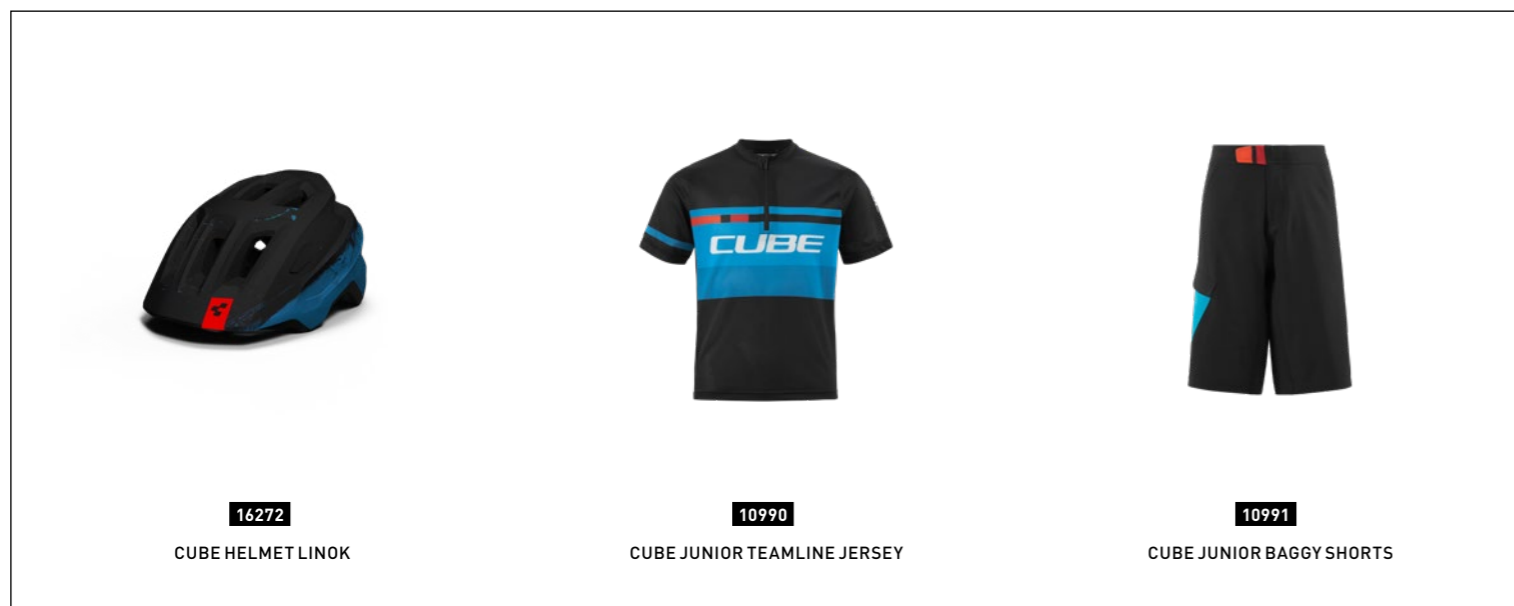

16272
CUBE HELMET LINOK

10990
CUBE JUNIOR TEAMLINE JERSEY

10991
CUBE JUNIOR BAGGY SHORTS

FOR us #Heroes

Building a great-looking full-suspension bike for youngsters is one thing. Building one that works brilliantly is quite another. It's a good job, then, that our design team's long experience with suspension kinematics means that the Stereo 120 Youth is every bit as good to ride on fast, rough trails as it is easy on the eye. You'll recognise the same kind of hydroformed frame tubes as we use on our adult bikes, carefully honed into two perfectly proportioned smaller frame sizes for younger riders. The short linkage, covered pivots and smooth suspension kinematics are straight from the Stereo 120 playback, too. Internal cable routing for reliable gear shifts, a replaceable gear hanger in case of accidents and a tapered head tube for ultra-precise steering are all standard. The ride and handling, on the other hand, definitely aren't. Your young ripper is going to be stoked on this...



STEREO 120 YOUTH

359100 actionteam



The enthusiasm of youth is something that's worth tapping into. So when your youngster is really ready to build their skills, what better way than aboard the brand-new Stereo 120 Youth? A full-on, no-compromise version of our acclaimed Stereo 120 full-suspension platform, it's designed and equipped to allow your young trail ripper to explore their limits... and come back for more. Available in two frame sizes, the hidden frame pivots, internal cable routing and compact rocker design contribute to this bike's super-clean looks. Just like the adult model on which it's based, it's stiff and strong where it needs to be, whilst remaining light and comfortable enough for day-long adventures. Triple-butted tubes help save weight, and hydroforming ensures there's rigidity and strength where it's needed – backed up, of course, by our rigorous in-house testing. A 12-speed Sram Eagle transmission gives even young legs the gear range they need to tackle any trail, while powerful hydraulic disc brakes make sure they're always in control on the descents. The suspension is handled by a Suntour air shock and fork, making it easy to adjust its performance to suit even the lightest riders so that they can enjoy the full benefit of our four-bar design. It's a package that's guaranteed to tap into their enthusiasm and bring them back with a smile on their face, ride after ride.

FRAME#HPA Ultralight, Advanced Hydroform, Triple Butted, ETC 4-Link, ISCG Mount
SIZE#3,5", 16"
FORK#R Suntour XCR34 Air, Tapered, 15x110mm, 120mm
SHOCK#R Suntour Edge R 190x45mm
SHOCK HARDWARE#op: 40x8mm, Bottom: 22x8mm

HEADSET#SA Orbit 1.5B ZS-1, Semi-Integrated, Top 1 1/8" Bottom 1 1/2"
STEM#UBE Performance Stem Pro, 31.8mm
HANDLEBAR#UBE Rise Trail Bar, 720mm
GRIPS#UBE Race SL Grip 29.5mm, 1-Clamp
REAR DERAILLEUR#Sram NX Eagle™, 12-Speed
SHIFTERS#Sram SX Eagle™ Trigger
BRAKE SYSTEM#Magura MT Thirty, Hydr. Disc Brake (180/180)
CRANKSET#Sram X1 1000 Eagle™ DUB 30T, Boost, 170mm
CASSETTE#Sram PG-1210 Eagle™, 11-50T
CHAIN#Sram SX Eagle™
RIMS#UBE MD23, 32H, Disc, Tubeless Ready
FRONT HUB#Shimano HB-MT400-B, 15mm, Boost, Centerlock
REAR HUB#Shimano FH-MT400-B, 12mm, Boost, Centerlock
TYRES#Schwalbe Hans Dampf, APerfL, 2.35
SADDLE#Natural Fit Venec Lite
SEAT POST#UBE Performance Post, 31.6mm
SEATCLAMP#UBE Varioclose, 34.9mm

WEIGHT#3,9 kg

SPARE PARTS#
8654 CUBE HANGER_mtb/rr-x12-std (18-06267)
10040 CUBE Disc Brake Pad Magura MT-2-4-6-8
10056 CUBE Disc Brake Pad Magura MT5

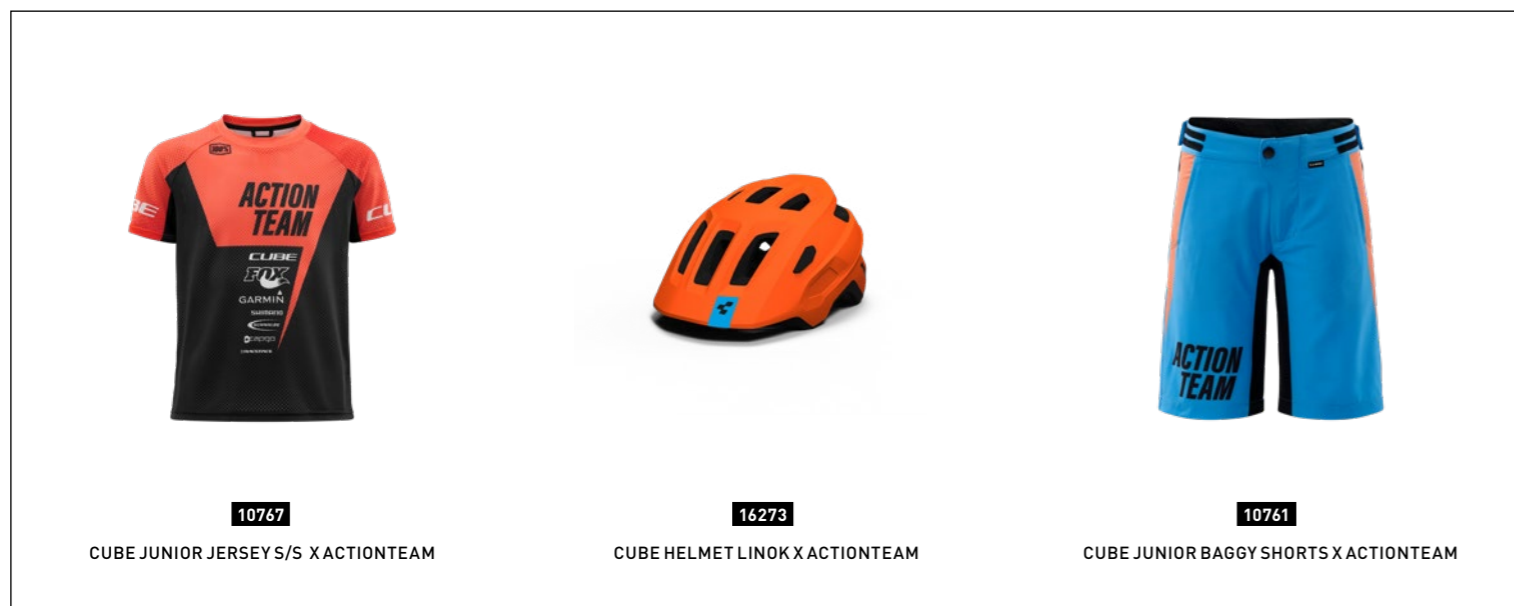

10767
 CUBE JUNIOR JERSEY S/S X ACTIONTEAM

16273
 CUBE HELMET LINOK X ACTIONTEAM

10761
 CUBE JUNIOR BAGGY SHORTS X ACTIONTEAM

GEO METRY

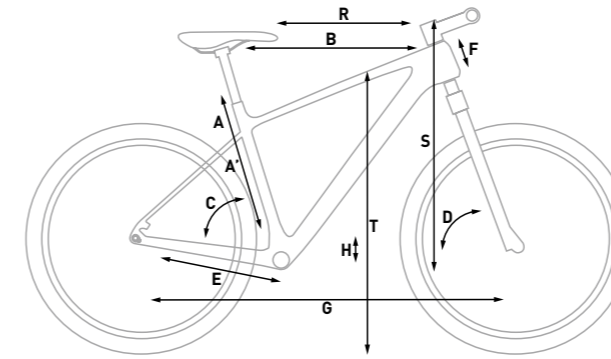

■ ELITE C:68 X

	A	A'	B	C	D	E	F	G	H	R	S	T
16"	370	332	575	73,8	69	424	90	1077	-63	402	602	739
18"	420	350	600	73,8	69	424	98	1103	-63	424	610	750
20"	470	400	625	73,8	69	424	111	1128	-63	446	622	781
22"	515	430	650	73,8	69	424	129	1155	-63	465	639	804

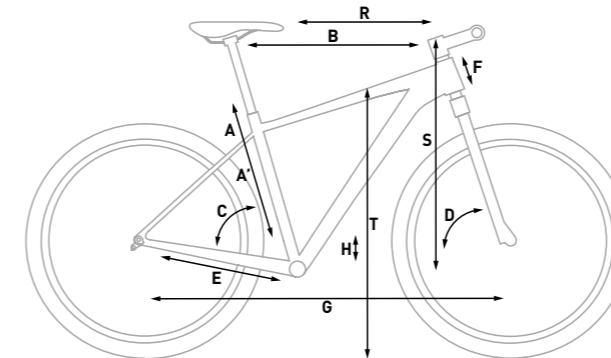

■ REACTION C:62

	A	A'	B	C	D	E	F	G	H	R	S	T
15"	370	315	567	73,5	69	423	100	1070	-65	388,8	609	726
17"	420	365	588	73,5	69	423	110	1091	-65	406,3	618	755
19"	470	415	609	73,5	69	423	120	1113	-65	424,8	627	791
21"	515	460	628	73,5	69	423	130	1133	-65	440,8	637	823
23"	565	515	648	73,5	69	423	145	1154	-65	456,4	651	859

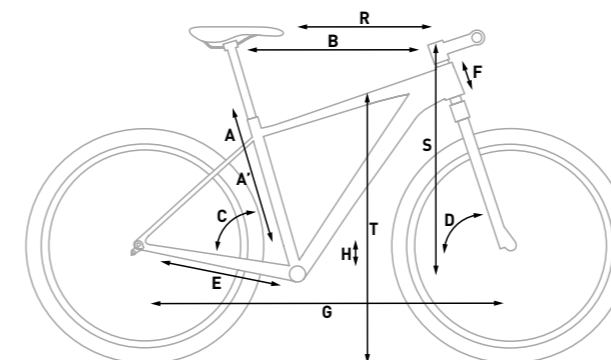

■ REACTION TM

	A	A'	B	C	D	E	F	G	H	R	S	T
16"	405	355	551	73,5	67	427	101,5	1115	-60,5	395	622	755
18"	450	407	568	73,5	67	427	106,5	1136	-60,5	415	627	785
20"	490	446	591	73,5	67	427	118,5	1161	-60,5	435	638	814
22"	540	511	618	73,5	67	427	134,5	1188	-60,5	455	653	850

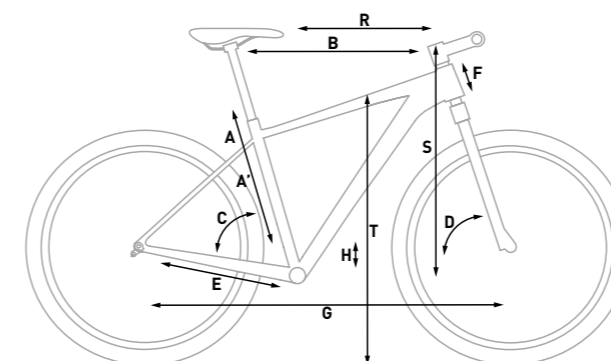

■ REACTION RACE

	A	A'	B	C	D	E	F	G	H	R	S	T
15"	370	320	558	73,5	69	410	103	1047	-51,5	387	610	718
17"	420	379	580	73,5	69	423	108,5	1084	-65	400	617	766
19"	470	429	600	73,5	69	423	119,5	1105	-65	416	627	802
21"	515	474	620	73,5	69	423	129,5	1125	-65	433	636	833
23"	565	524	640	73,5	69	423	144,5	1146	-65	449	650	869

LEGEND

- A SEAT TUBE MM
- A' SEAT TUBE CENTER-CENTER MM
- B TOP TUBE HORIZONTAL MM
- C SEAT TUBE DEGREE
- D HEAD TUBE ANGLE DEGREE
- E CHAIN STAYS MM
- F HEAD TUBE MM
- G WHEELSBASE MM
- H BB-HEIGHT TO HUB MM
- I REAR TRAVEL MM
- R REACH MM
- S STACK MM
- T STANDOVER HEIGHT - 80MM FROM THE BB MM



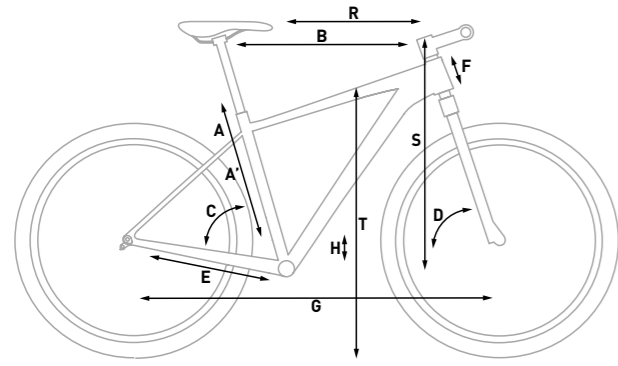

■ AIM / ANALOG / ATTENTION

	A	A'	B	C	D	E	F	G	H	R	S	T
14"	355	310	545	74	69	427	106	1052	-51,5	374	595	710
16"	405	363	561	73,5	69	427	109	1063	-51,5	384	608	745
18"	450	406	585	73,5	69	427	129	1088	-51,5	402	617	780

	A	A'	B	C	D	E	F	G	H	R	S	T
17"	420	375	575	73,5	69	450	108,5	1105	-65	391	623	769
19"	470	425	595	73,5	69	450	119,5	1125	-65	407	633	805
21"	515	470	615	73,5	69	450	129,5	1146	-65	425	642	836
23"	565	520	635	73,5	69	450	144,5	1167	-65	441	657	871

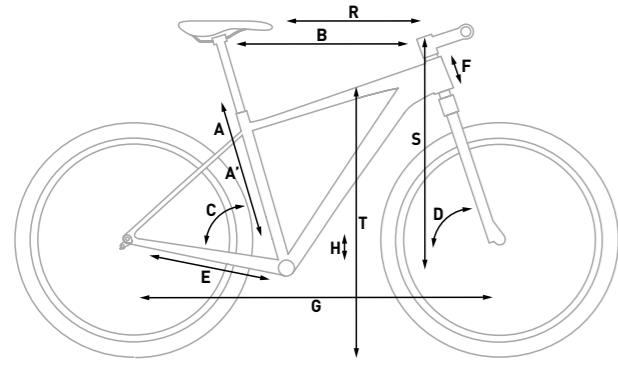

■ ACID / RACE ONE / REACTION PRO

	A	A'	B	C	D	E	F	G	H	R	S	T
14"	355	310	545	74	69	427	106	1052	-51,5	374	595	712
16"	405	363	561	73,5	69	427	109	1063	-51,5	380	608	746
18"	450	406	585	73,5	69	427	129	1088	-51,5	402	617	788

	A	A'	B	C	D	E	F	G	H	R	S	T
17"	420	375	575	73,5	69	450	108,5	1105	-65	389	627	772
19"	470	425	595	73,5	69	450	119,5	1125	-65	407	637	805
21"	515	470	615	73,5	69	450	129,5	1146	-65	425	643	847
23"	565	520	635	73,5	69	450	144,5	1167	-65	440	660	871

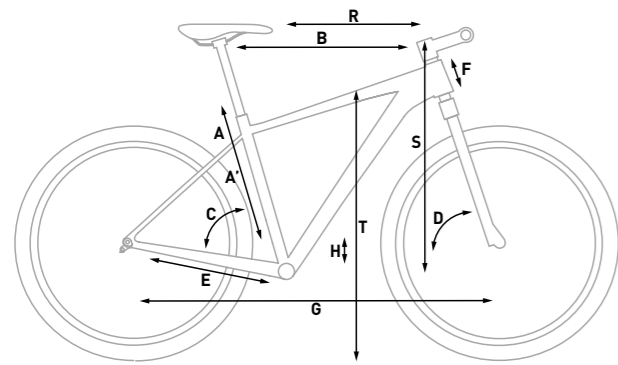

■ NUTRIL

	A	A'	B	C	D	E	F	G	H	R	S	T
15"	370	316	570	73	69	443	105	1089	-65	381	625	738
17"	420	368	588	73	69	443	105	1106	-65	398	625	771
19"	470	418	609	73	69	443	115	1128	-65	417	634	807
21"	515	465	628	73	69	443	125	1148	-65	433	643	837

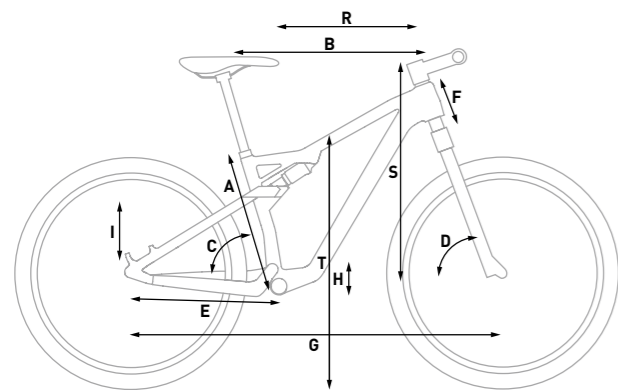

■ AMS 100 C:68

	A	B	C	D	E	F	G	H	I	R	S	T
16"	370	565	74,5	70	443	97	1099	-42	100	405	590	740
18"	420	590	74,5	70	443	107	1125	-42	100	427	600	738
20"	470	613	74,5	70	443	117	1149	-42	100	447	609	739
22"	520	636	74,5	70	443	127	1172	-42	100	467	618	743

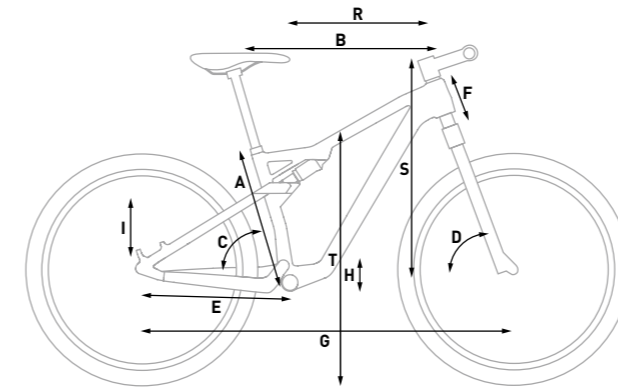

■ AMS 100 C:68 TM / RACE

	A	B	C	D	E	F	G	H	I	R	S	T
16"	370	569	73,2	68,7	443	97	1109	-32	100	391	599	750
18"	420	594	73,2	68,7	443	107	1134	-32	100	414	609	748
20"	470	617	73,2	68,7	443	117	1158	-32	100	434	618	749
22"	520	640	73,2	68,7	443	127	1181	-32	100	454	628	753

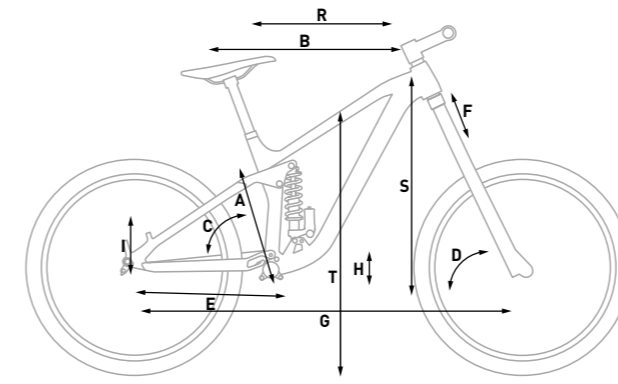

■ STEREO 170 HPA 29 | ANGLE SET +

	A	B	C	D	E	F	G	H	I	R	S	T
18"	420	582	76,5	65	434,5	103	1212	-25	170	444	621	745
20"	470	606	76,5	65	434,5	113	1237	-25	170	464	630	752
22"	520	632	76,5	65	434,5	133	1265	-25	170	484	648	794

■ STEREO 170 HPA 29 | ANGLE SET -

	A	B	C	D	E	F	G	H	I	R	S	T
18"	420	581	76,7	64,4	434,5	103	1220	-26,6	170	446	619	743
20"	470	604	76,7	64,4	434,5	113	1244	-26,6	170	466	628	750
22"	520	631	76,7	64,4	434,5	133	1273	-26,5	170	486	646	792

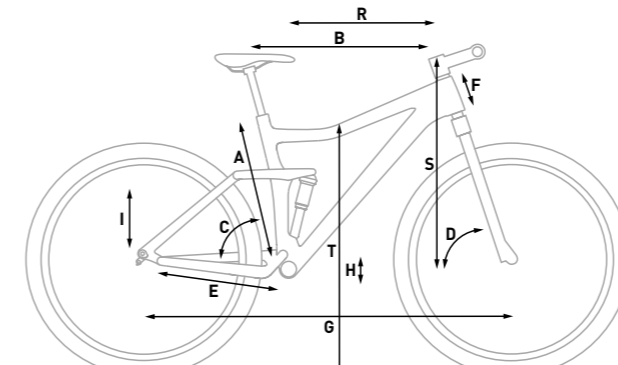

■ STEREO 150 C:68 / C:62

	A	B	C	D	E	F	G	H	I	R	S	T
16"	375	571	75,5	66	435	95	1167	-34	150	417	619	736
18"	425	592	75,5	66	435	100	1189	-34	150	437	624	752,6
20"	470	616	75,5	66	435	110	1213	-34	150	457	633	766
22"	520	643	75,5	66	435	130	1241	-34	150	477	651	801

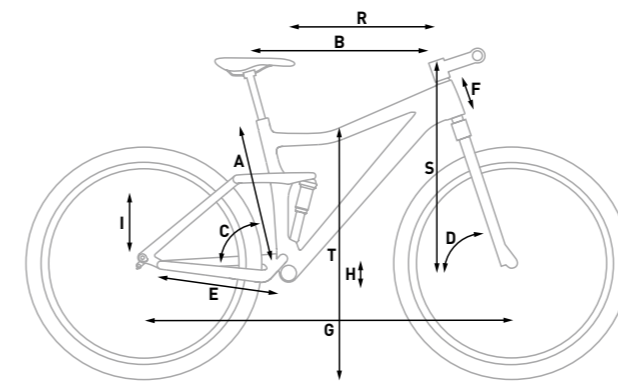

■ STEREO 140 HPC

	A	B	C	D	E	F	G	H	I	R	S	T
16"	370	568	75,2	66,5	425	107	1141	-15,5	140	418	592	733
18"	420	591	75,2	66,5	425	117	1165	-15,5	140	438	601	734
20"	470	614	75,2	66,5	425	127	1189	-15,5	140	458	610	756
22"	520	640	75,2	66,5	425	147	1217	-15,5	140	478	628	765

LEGEND

- A SEAT TUBE MM
- A' SEAT TUBE CENTER-CENTER MM
- B TOP TUBE HORIZONTAL MM
- C SEAT TUBE DEGREE
- D HEAD TUBE ANGLE DEGREE
- E CHAIN STAYS MM
- F HEAD TUBE MM
- G WHEELBASE MM
- H BB-HEIGHT TO HUB MM
- I REAR TRAVEL MM
- R REACH MM
- S STACK MM
- T STANDOVER HEIGHT - 80MM FROM THE BB MM

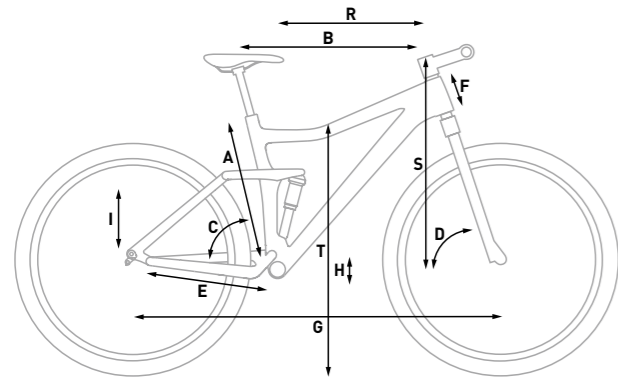

■ STEREO 120

	A	B	C	D	E	F	G	H	I	R	S	T
16"	370	569,9	75,3	67	435,5	100	1145	-40	120	420	603	696
18"	420	590,8	75,3	67	435,5	103	1166	-40	120	440	606	739
20"	470	614	75,3	67	435,5	113	1190	-40	120	460	615	769,8
22"	520	640,3	75,3	67	435,5	133	1218	-40	120	480	634	810,4

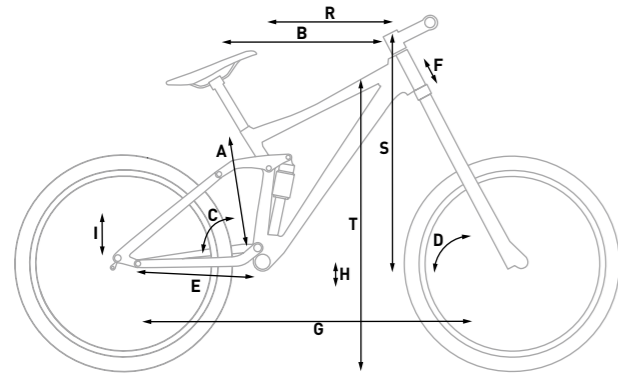

■ TWO 15

M	A	B	C	D	E	F	G	H	I	R	S	T
	420	592	72,5	63	436	124	1221	-8	215	415	620	789,8

L	A	B	C	D	E	F	G	H	I	R	S	T
	420	564	78,2	63,8	445	124	1253	-27,5	200	435	656,6	787,5

XL	A	B	C	D	E	F	G	H	I	R	S	T
	420	584	78,2	63,8	445	124	1273	-27,5	200	455	656	784,9

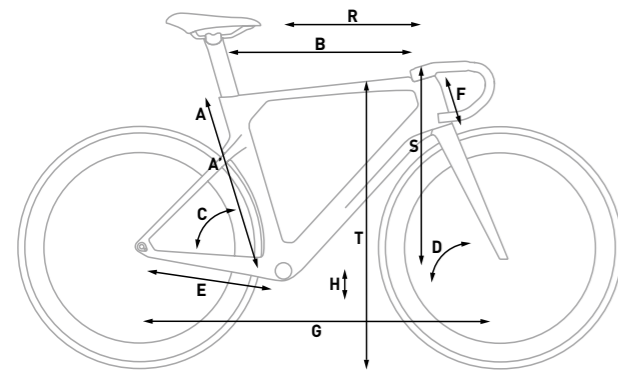

■ LITENING C:68 X

	A	A'	B	C	D	E	F	G	H	R	S	T
50CM	460	458	527	75	72,3	410	95	981	-72	389	514	814
52CM	480	478	537	74,2	72,5	410	105	981	-72	388	524	829
54CM	500	500	550	73,5	73	410	125	980	-69	389	542	848
56CM	520	519	565	73,5	73,5	410	145	990	-69	398	563	867
58CM	540	538	580	73	73,5	410	165	1001	-67	403	580	885
60CM	560	560	592	72,5	73,5	410	180	1010	-67	405	595	902

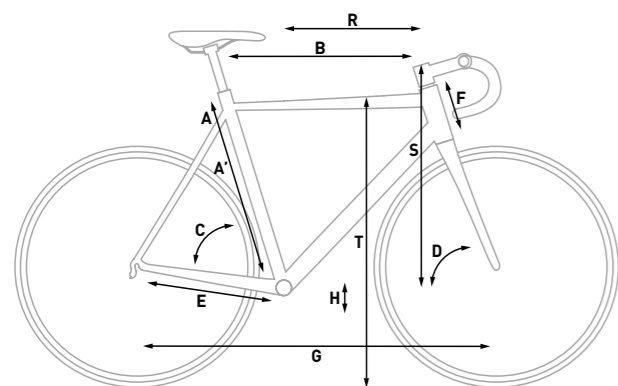

■ AGREE C:62

	A	A'	B	C	D	E	F	G	H	R	S	T
50CM	440	428	522	74,6	71,5	412	120	984	-73	378	523	732
53CM	470	458	539	74	72	412	140	992	-73	383	544	758
56CM	500	488	560	73,5	72,5	412	170	1006	-71	390	573	788
58CM	520	508	575	73	72,5	412	190	1014	-71	394	592	807
60CM	540	528	590	72,5	72,5	412	208	1025	-69	399	607	826
62CM	560	548	600	72,5	72,5	412	231	1036	-69	402	629	846

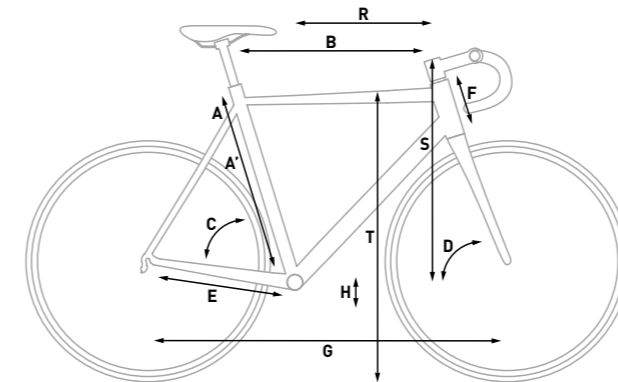

■ ATTAIN (* KEIN 47CM BEI RACE / SL)

	A	A'	B	C	D	E	F	G	H	R	S	T
47CM	430	380	510	74,6	70,6	410	120	980	-74	365	525	700
50CM	460	410	517	74,6	71,5	410	130	980	-74	369	538	723
53CM	490	440	537	74	72	410	152	990	-74	376	561	750
56CM	520	470	560	73,5	72,5	410	182	1004	-74	385	591	780
58CM	540	490	575	73	72,5	410	202	1013	-74	388	610	799
60CM	560	510	590	72,5	72,5	412	222	1022	-74	392	629	818
62CM	580	530	595	72,5	72,5	412	242	1027	-74	391	649	838

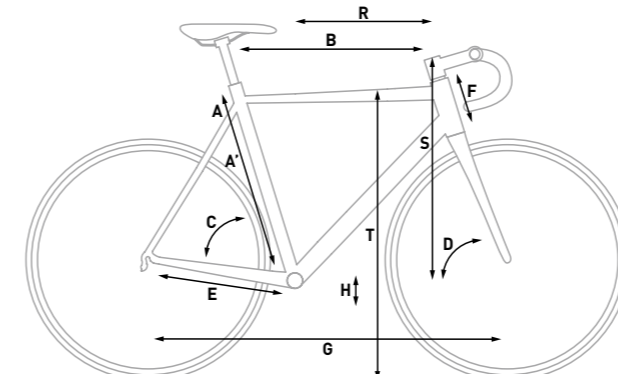

■ ATTAIN 6TC

	A	A'	B	C	D	E	F	G	H	R	S	T
50CM	460	410	517	74,6	71,5	415	130	985	-74	369	538	723
53CM	490	440	537	74	72	415	152	995	-74	376	561	750
56CM	520	470	560	73,5	72,5	415	182	1009	-74	385	591	780
58CM	540	490	575	73	72,5	415	202	1018	-74	388	610	799
60CM	560	510	590	72,5	72,5	417	222	1030	-74	392	629	818
62CM	580	530	595	72,5	72,5	417	242	1034	-74	391	649	838

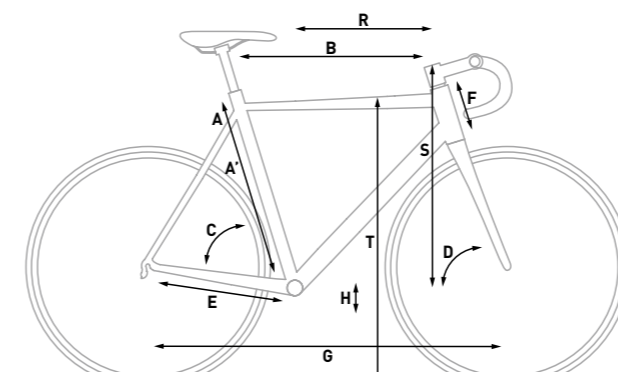

■ CROSS RACE C:62

	A	A'	B	C	D	E	F	G	H	R	S	T
50CM	500	460	518	75	70,5	430	115	1013	-68	376	530	762
53CM	530	490	536	74	70,8	430	140	1019	-68	377	555	789
56CM	560	520	554	73,5	72	430	160	1021	-68	383	578	816
58CM	580	540	570	73	72,5	430	180	1027	-68	387	599	835
61CM	610	570	588	73	73	430	205	1040	-68	397	625	862

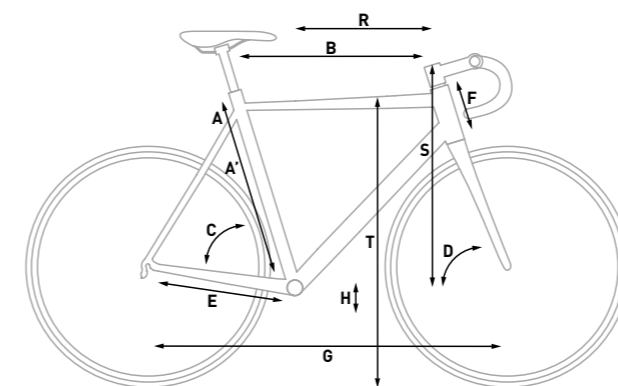

■ CROSS RACE

	A	A'	B	C	D	E	F	G	H	R	S	T
50CM	470	459	525	75	71	422	107	1009	-64	387	520	762
53CM	500	489	539	74,5	71,5	422	130	1016	-64	390	544	789
56CM	530	515	558	73,5	72	422	152	1020	-64	393	566	816
58CM	550	538	575	73	72	422	172	1033	-64	398	585	835
61CM	580	568	590	73	72,5	422	195	1043	-64	406	609	862

LEGEND

A SEAT TUBE MM	E CHAIN STAYS MM	R REACH MM
A' SEAT TUBE CENTER-CENTER MM	F HEAD TUBE MM	S STACK MM
B TOP TUBE HORIZONTAL MM	G WHEELBASE MM	T STANDOVER HEIGHT - 80MM FROM THE BB MM
C SEAT TUBE DEGREE	H BB-HEIGHT TO HUB MM	
D HEAD TUBE ANGLE DEGREE	I REAR TRAVEL MM	

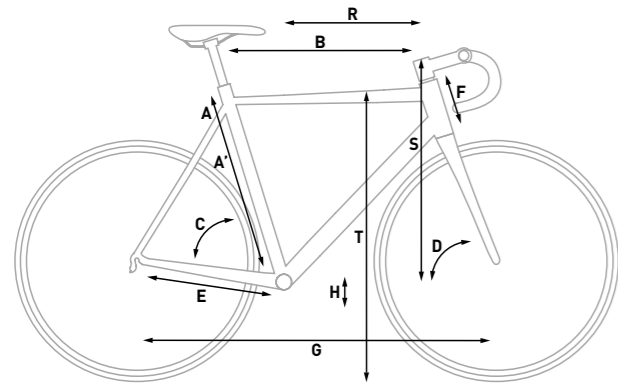

■ NUROAD

	A	A'	B	C	D	E	F	G	H	R	S	T
50CM	470	425	517	75,2	70	430	118	1018	-70	376	533	744
53CM	500	455	537	74,5	71	430	140	1023	-70	382	557	771
56CM	530	485	560	73,5	71,5	430	170	1032	-70	386	588	801
58CM	550	505	575	73	72	430	190	1037	-70	389	609	821
61CM	580	535	592	73	72,5	430	213	1048	-70	398	632	848

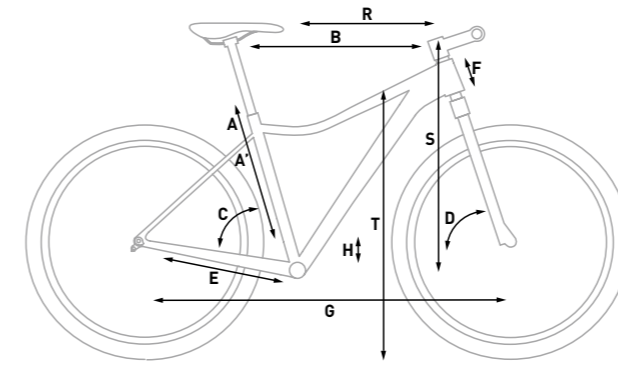

■ ACCESS WS C:62

	A	A'	B	C	D	E	F	G	H	R	S	T
13,5"	355	305	548	73,5	69	410	95	1036	-51,5	379	581	705
15"	370	315	567	73,5	69	423	100	1070	-65	389	609	726
17"	420	365	588	73,5	69	423	110	1091	-65	406	618	755
19"	470	415	609	73,5	69	423	120	1113	-65	425	627	791

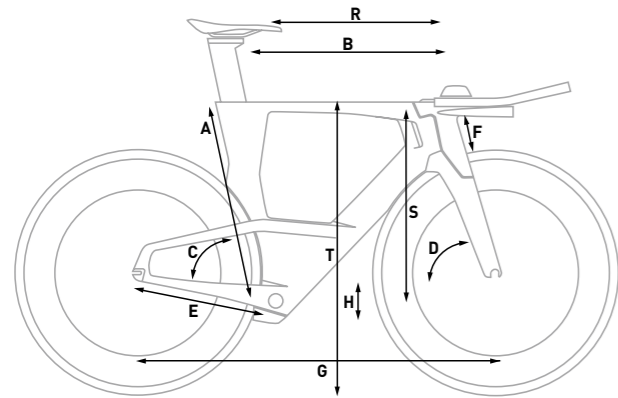

■ AERIUM C:68 SL / SLT

	A	B	C	D	E	F	G	H	R	S	T
XS	535	499	78	72	395	74	964	-78	396	487	782
S	545	511	78	72	395	85	977	-78	405	498	798
M	566	531	78	72	395	106	999	-78	421	518	818
L	588	557	78	72	395	129	1028	-78	442	540	840

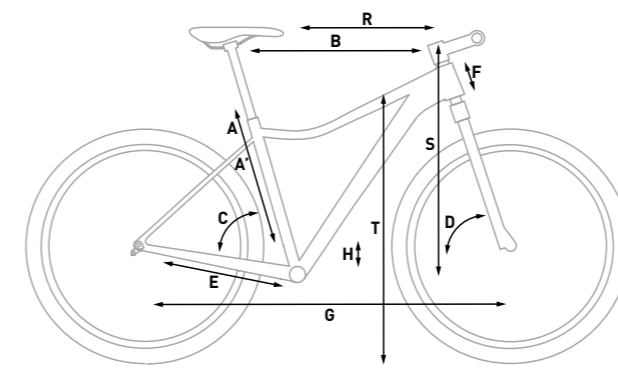

■ ACCESS WS SL

	A	A'	B	C	D	E	F	G	H	R	S	T
13,5"	355	315	540	74	69	427	111	1047	-51,5	367,9	597	671
16"	405	367	556	73,5	69	427	114	1058	-51,5	377,4	602,8	707
17"	420	382	570	73	69,5	450	113,5	1100	-65	384	627,6	717
19"	470	433	590	73	70	450	124,5	1121	-65	401	637,8	747

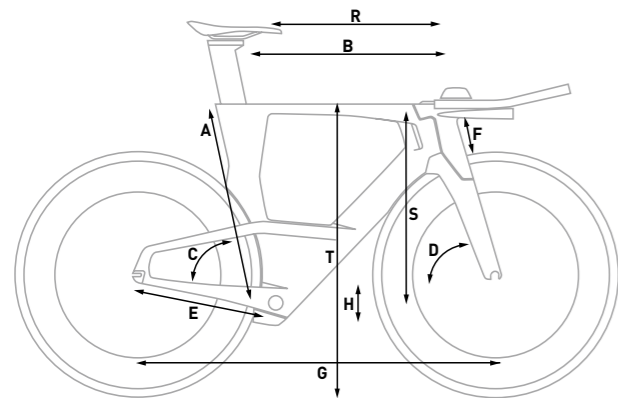

■ AERIUM C:68 TT

	A	B	C	D	E	F	G	H	R	S	T
XS	535	499	78	72	408	74	977	-78	396	487	782
S	545	511	78	72	408	85	990	-78	405	498	798
M	566	531	78	72	408	106	1013	-78	421	518	818
L	588	557	78	72	408	129	1041	-78	442	540	840

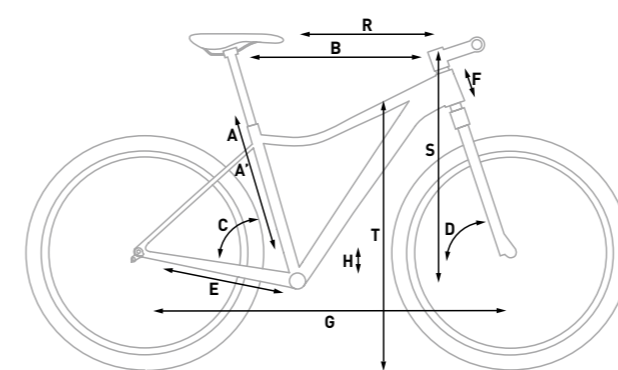

■ ACCESS WS

	A	B	C	D	E	F	G	H	R	S	T
13,5"	355	540	74	69	427	111	1047	-51,5	367,9	597	671
16"	405	556	73,5	69	427	114	1058	-51,5	377,4	602,8	707
17"	420	570	73	69,5	450	113,5	1100	-65	384	627,6	717
19"	470	590	73	70	450	124,5	1121	-65	401	637,9	747

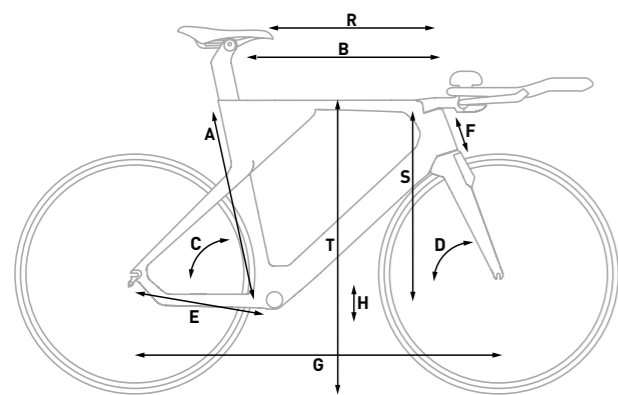

■ AERIUM C:68 RACE

	A	B	C	D	E	F	G	H	R	S	T
S	544	510	77	71,5	395	95	976	-70	395	498	800
M	559	530	77,5	72	395	110	998	-70	416	514	817
L	574	550	78	72,5	395	125	1019	-70	437	530	832

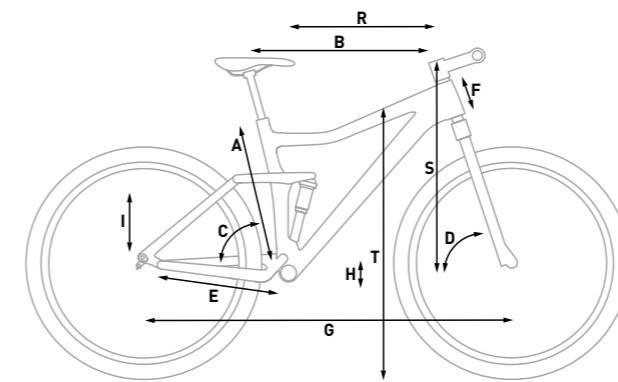

■ STING WS 140 HPC 27.5"

	A	B	C	D	E	F	G	H	I	R	S	T
13,5"	350	546	75,2	66,5	425	140	102	1119	-15,5	398	587	732
16"	370	568	75,2	66,5	425	140	107	1141	-15,5	418	592	733
18"	420	591	75,2	66,5	425	140	117	1165	-15,5	438	601	734
20"	470	614	75,2	66,5	425	140	127	1189	-15,5	458	610	756

LEGEND

A SEAT TUBE MM	E CHAIN STAYS MM	R REACH MM
A' SEAT TUBE CENTER-CENTER MM	F HEAD TUBE MM	S STACK MM
B TOP TUBE HORIZONTAL MM	G WHEELBASE MM	T STANDOVER HEIGHT - 80MM FROM THE BB MM
C SEAT TUBE DEGREE	H BB-HEIGHT TO HUB MM	
D HEAD TUBE ANGLE DEGREE	I REAR TRAVEL MM	

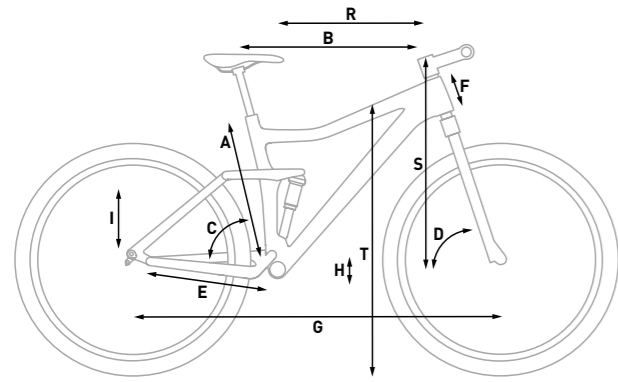

■ STING WS 120

	A	B	C	D	E	F	G	H	I	R	S	T
13,5"	340	547	75,3	67,5	417	120	100	1096	-20	405	567,3	699
16"	370	570	75,3	67	432,5	120	100	1145	-40	420	603	706
18"	420	590,8	75,3	67	432,5	120	103	1166	-40	440	606	739
20"	470	614	75,3	67	432,5	120	113	1190	-40	460	615	769,8

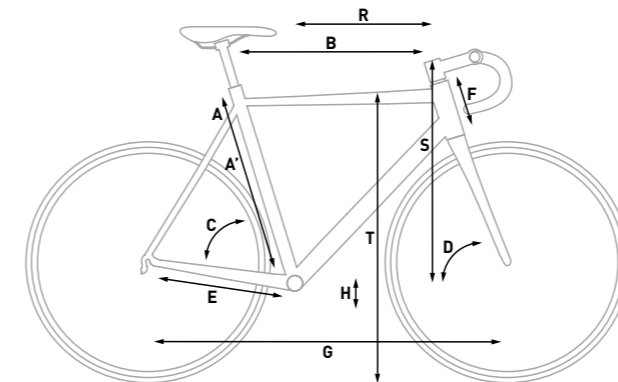

■ AXIAL WS

	A	A'	B	C	D	E	F	G	H	R	S	T
47CM	430	380	510	74,6	70,6	410	120	980	-74	365	525	700
50CM	460	410	517	74,6	71,5	410	130	980	-74	369	538	723
53CM	490	440	537	74	72	410	152	990	-74	376	561	750
56CM	520	470	560	73,5	72,5	410	182	1004	-74	385	591	780

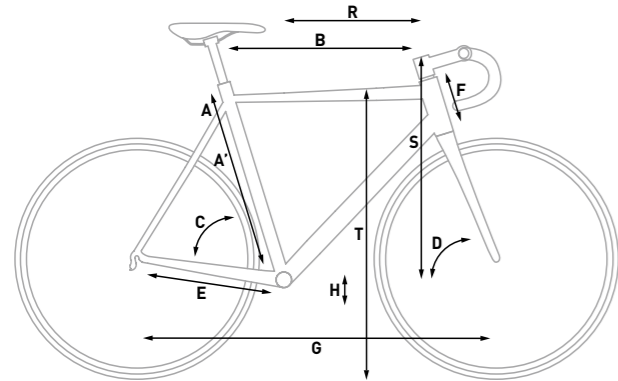

■ AXIAL WS C:62 SL DISC

	A	A'	B	C	D	E	F	G	H	R	S	T
47CM	410	398	517	74,6	71	412	112	984	-73	374	514	710
50CM	440	428	522	74,6	71,5	412	120	984	-73	378	523	732
53CM	470	458	539	74	72	412	140	992	-73	383	544	758
56CM	500	488	560	73,5	72,5	412	170	1006	-71	390	573	788

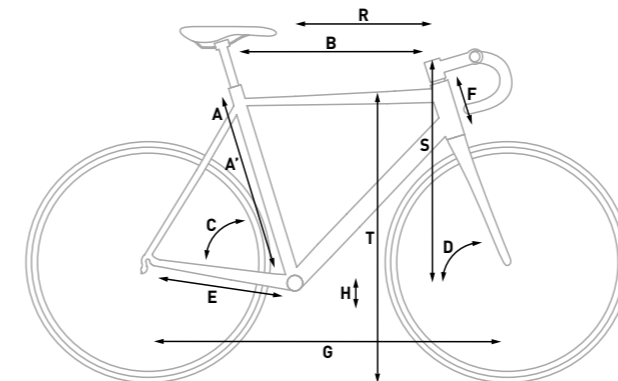

■ NUROAD WS

	A	A'	B	C	D	E	F	G	H	R	S	T
50CM	470	425	517	75,2	70	430	118	1018	-70	376	533	744
53CM	500	455	537	74,5	71	430	140	1023	-70	382	557	771
56CM	530	485	560	73,5	71,5	430	170	1032	-70	386	588	801
58CM	550	505	575	73	72	430	190	1037	-70	389	609	821

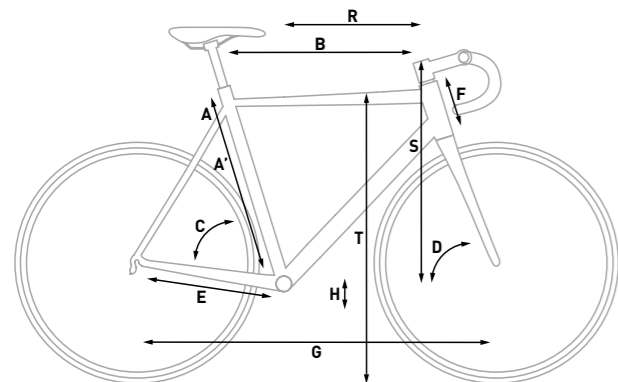

■ AXIAL WS GTC

	A	A'	B	C	D	E	F	G	H	R	S	T
47CM	430	380	510	74,6	70,6	415	120	980	-74	365	525	700
50CM	460	410	517	74,6	71,5	415	130	985	-74	369	538	723
53CM	490	440	537	74	72	415	152	995	-74	376	561	750
56CM	520	470	560	73,5	72,5	415	182	1009	-74	385	591	780

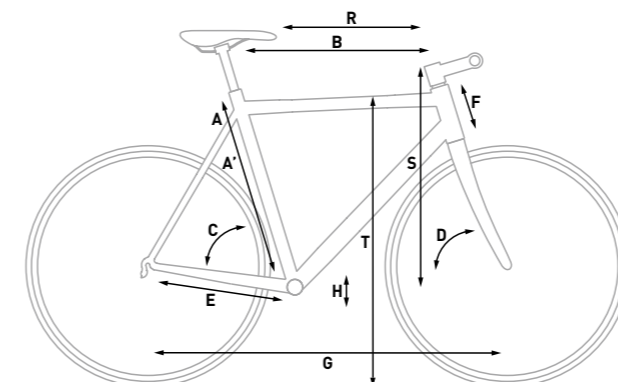

■ CROSS / SL / EXC / PRO / ALLROAD

	A	A'	B	C	D	E	F	G	H	R	S	T
46CM	460	415	570	73	71	445	105	1057	-60	389	591	776
50CM	500	455	585	73	71	445	120	1078	-60	401	607	805
54CM	540	495	600	73	71	445	140	1088	-60	410	622	837
58CM	580	535	615	73	71	445	155	1104	-60	421	636	866
62CM	620	575	622	73	71	445	170	1112	-60	423	650	895

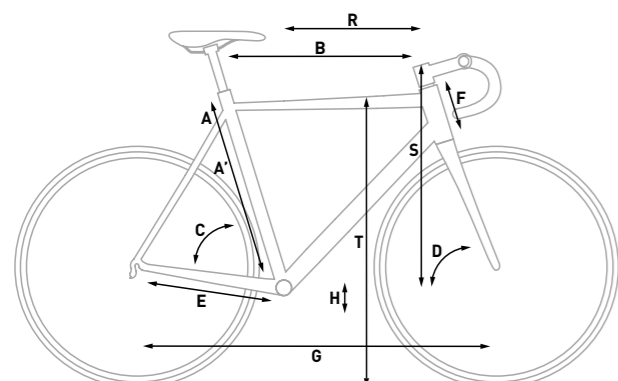

■ AXIAL WS PRO / AXIAL WS RACE

	A	A'	B	C	D	E	F	G	H	R	S	T
47CM	430	380	510	74,6	70,6	415	120	980	-74	365	525	700
50CM	460	410	517	74,6	71,5	415	130	985	-74	369	538	723
53CM	490	440	537	74	72	415	152	995	-74	376	561	750
56CM	520	470	560	73,5	72,5	415	182	1009	-74	385	591	780

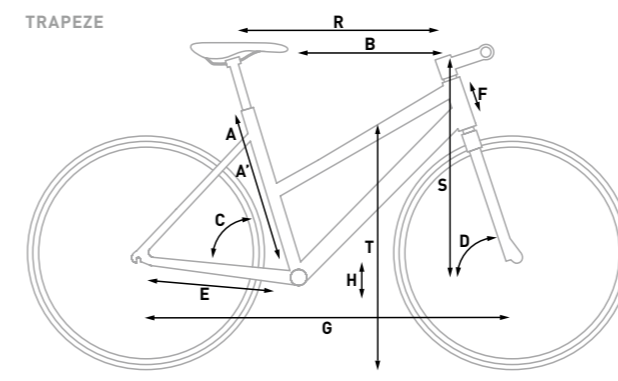

■ CROSS / SL / EXC / PRO / ALLROAD

	A	B	C	D	E	F	G	H	R	S	T
Z46CM	460	570	73	71	445	130	1058	-60	382	614	642
Z50CM	500	585	73	71	445	140	1078	-60	390	623	651
Z54CM	540	600	73	71	445	160	1088	-60	410	643	668

LEGEND

- A SEAT TUBE MM
- A' SEAT TUBE CENTER-CENTER MM
- B TOP TUBE HORIZONTAL MM
- C SEAT TUBE DEGREE
- D HEAD TUBE ANGLE DEGREE
- E CHAIN STAYS MM
- F HEAD TUBE MM
- G WHEELSBASE MM
- H BB-HEIGHT TO HUB MM
- I REAR TRAVEL MM
- R REACH MM
- S STACK MM
- T STANDOVER HEIGHT - 80MM FROM THE BB MM

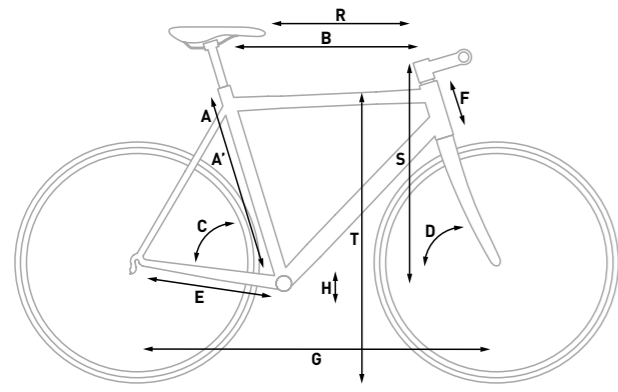

■ NATURE SL/EXC/PRO/ALLROAD

	A	A'	B	C	D	E	F	G	H	R	S	T
46CM	460	415	570	73	71	445	105	1057	-60	389	591	776
50CM	500	455	585	73	71	445	120	1078	-60	401	607	805
54CM	540	495	600	73	71	445	140	1088	-60	410	622	837
58CM	580	535	615	73	71	445	155	1104	-60	421	636	866
62CM	620	575	622	73	71	445	170	1112	-60	423	650	894

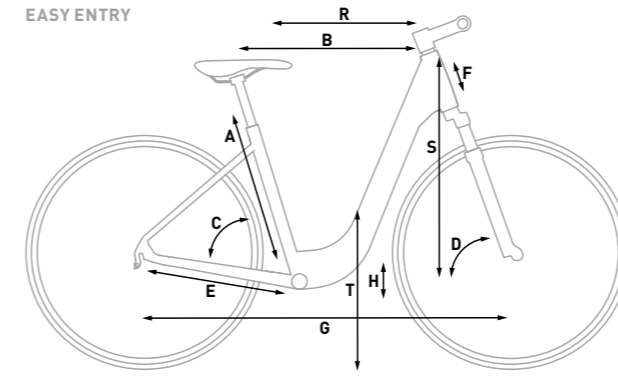

■ TOURING/TOWN/ELLA

	A	B	C	D	E	F	G	H	R	S	T
EE 45CM	450	578	73	70	455	170	1082	-75	379	650	435,4
EE 49CM	490	593	73	70	455	185	1098	-75	390	665	435,5
EE 53CM	530	608	73	70	455	200	1114	-75	401	679	435,7

TRAPEZE

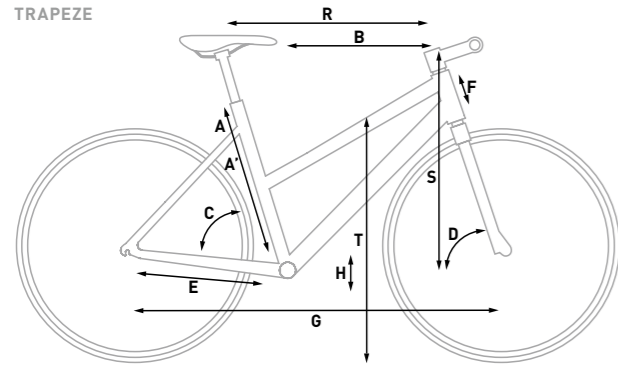

■ NATURE SL/EXC/PRO/ALLROAD

	A	B	C	D	E	F	G	H	R	S	T
Z46CM	460	570	73	71	445	130	1058	-60	382	614	642
Z50CM	500	580	73	71	445	140	1078	-60	390	623	651
Z54CM	540	595	73	71	445	160	1088	-60	410	643	668

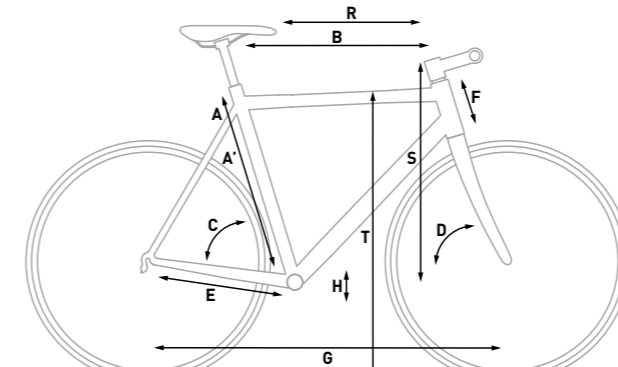

■ TRAVEL SPORT
SL ROAD/SL/RACE/PRO

	A	A'	B	C	D	E	F	G	H	R	S	T
50CM	460	410	542	74	70,5	430	125	1030	-60	389	534	740
53CM	490	440	566	73	71,5	430	145	1035	-60	396	557	766
56CM	520	470	574	73	72	430	160	1039	-60	399	573	790
59CM	550	500	593	73	72	430	185	1058	-60	411	597	816
62CM	580	530	612	73	72	430	215	1078	-60	421	626	845

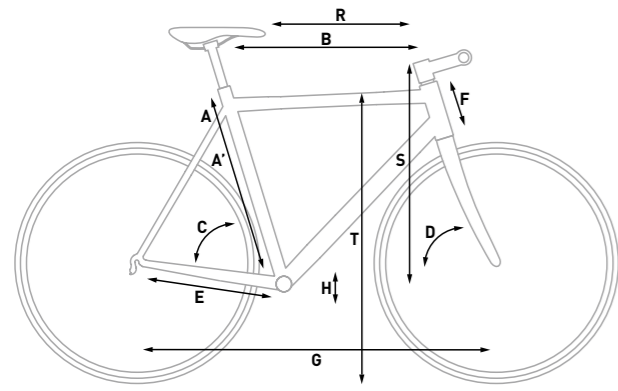

■ KATHMANDU SL/EXC/PRO
TOURING/EXC/PRO/TOURING
NATURE

	A	A'	B	C	D	E	F	G	H	R	S	T
46CM	460	405	558	73	70	445	110	1056	-60	377	592	767
50CM	500	445	569	73	70,5	445	130	1063	-60	382	613	800
54CM	540	485	583	73	71	445	150	1072	-60	389	634	831
58CM	580	525	598	73	71	445	170	1088	-60	399	653	862
62CM	620	565	613	73	71	445	190	1103	-60	408	671	892

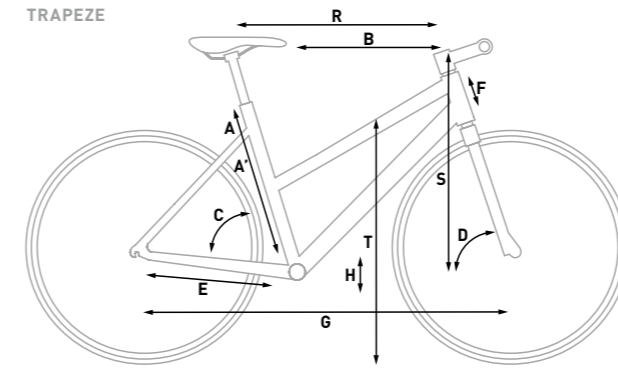

■ TRAVEL SPORT
SL ROAD/PRO

	A	A'	B	C	D	E	F	G	H	R	S	T
Z 47CM	430	220	517	75	70	430	120	1020	-60	376	528	609
Z 50CM	460	230	537	74,5	70,5	430	130	1031	-60	388	539	617
Z 53CM	490	240	561	74	71,5	430	150	1046	-60	405	562	629

TRAPEZE

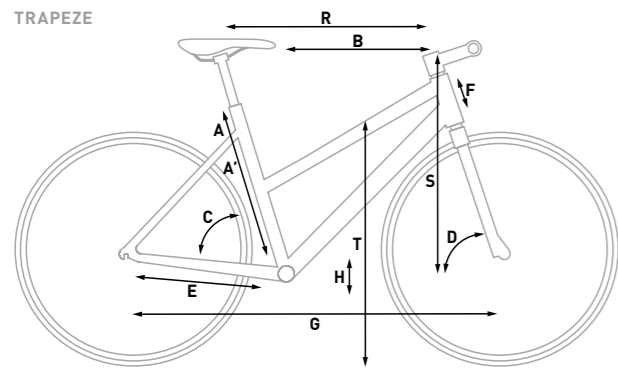

■ KATHMANDU SL/EXC/PRO
TOURING/EXC/PRO/TOURING
NATURE

	A	A'	B	C	D	E	F	G	H	R	S	T
Z 46CM	460	216	563	73	70,5	445	150	1058	-60	370	631	553
Z 50CM	500	226	578	73	71	445	150	1067	-60	384	634	549
Z 54CM	540	243	593	73	71	445	185	1083	-60	389	667	590

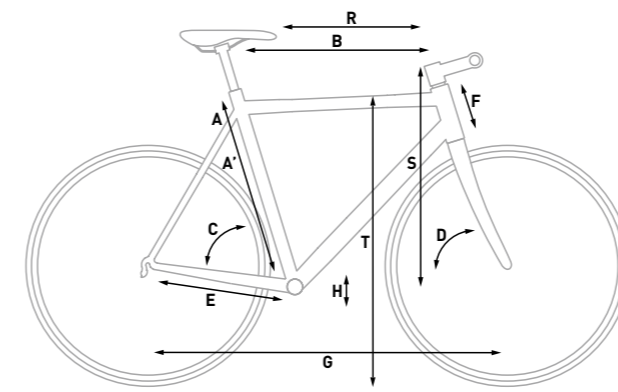

■ TRAVEL/PRO/
HYDE/PRO

	A	A'	B	C	D	E	F	G	H	R	S	T
46CM	440	390	551	74,5	69	470	115	1098	-70	392	575	760
50CM	480	430	565	74	70	470	135	1098	-70	394	598	794
54CM	520	470	580	73,5	71	470	155	1098	-70	396	621	828
58CM	560	510	595	73	71	470	175	1108	-70	399	640	859
62CM	600	550	605	73	71	470	200	1119	-70	402	663	892

LEGEND

- A SEAT TUBE MM
- A' SEAT TUBE CENTER-CENTER MM
- B TOP TUBE HORIZONTAL MM
- C SEAT TUBE DEGREE
- D HEAD TUBE ANGLE DEGREE
- E CHAIN STAYS MM
- F HEAD TUBE MM
- G WHEELBASE MM
- H BB-HEIGHT TO HUB MM
- I REAR TRAVEL MM
- R REACH MM
- S STACK MM
- T STANDOVER HEIGHT - 80MM FROM THE BB MM

TRAPEZE

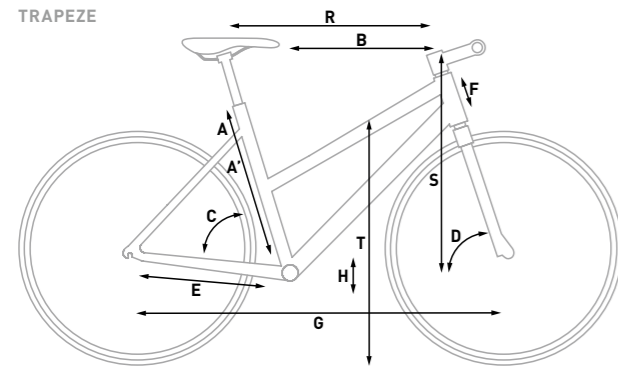

■ TRAVEL / PRO / HYDE / PRO

	A	A'	B	C	D	E	F	G	H	R	S	T
Z 46CM	440	240	551	74,5	69	470	125	1099	-70	389	584	660
Z 50CM	480	240	565	74	70	470	145	1099	-70	391	607	668
Z 54CM	520	240	580	73,5	71	470	165	1099	-70	393	630	676

■ CUBIE 120

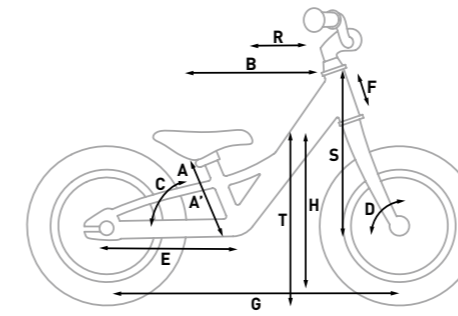

12"	A	B	C	D	E	F	G	H	R	S	T
	170	320	72	70	250	80	606	10	230,2	276,3	333,7

■ EDITOR HYDE RACE TRAVEL SLT / SL

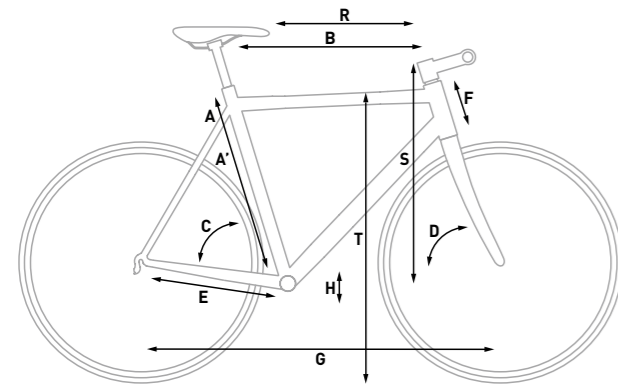

	A	B	C	D	E	F	G	H	R	S	T
46CM	440	560	73	70	430	135	1048	-50	395,8	537	745,4
50CM	480	570	73	71	430	150	1048	-50	400,3	555,1	777,3
54CM	520	586	73	72	430	170	1055	-50	409,5	577,5	810,2
58CM	560	596	73	72	430	190	1066	-50	413,5	596,9	841,5
62CM	600	607	73	72	430	210	1077	-50	418,7	616	872,3

■ CUBIE 160

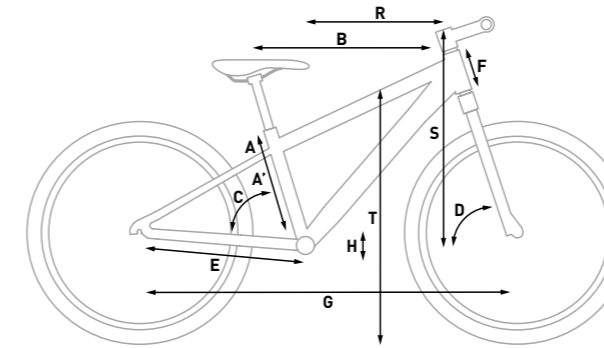

16"	A	A'	B	C	D	E	F	G	H	R	S	T
	205	157	368	73	69	303	100	727	7	263	343	446

TRAPEZE

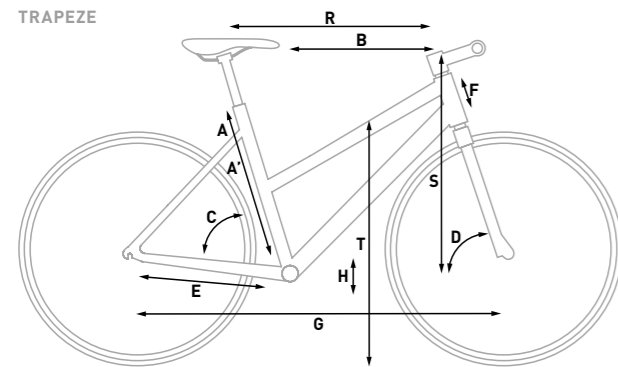

■ HYDE RACE TRAVEL SLT / SL

	A	A'	B	C	D	E	F	G	H	R	S	T
Z 46CM	440	240	560	73	70	430	145	1049	-50	393	546	645
Z 50CM	480	240	570	73	71	430	160	1049	-50	398	564	650
Z 54CM	520	240	586	73	72	430	180	1055	-50	407	587	656

■ CUBIE 180

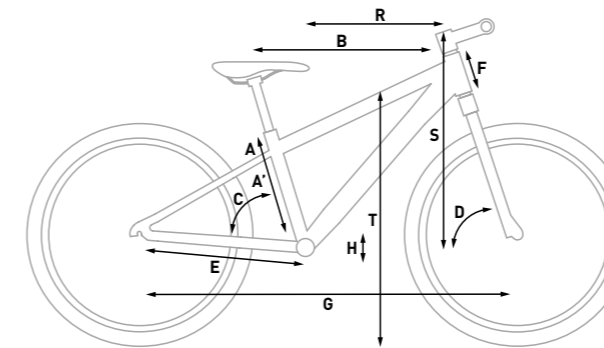

18"	A	B	C	D	E	F	G	H	R	S	T
	225	405	73	70	314	105	798	10	285,7	390,3	483,9

■ CUBIE 120 WALK

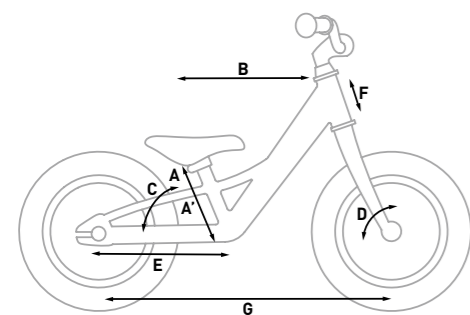

12"	A	A'	B	C	D	E	F	G
	122	93	307	67	72	250	90	555

■ ACID 200 / ACID 200 ALLROAD / KID 200 STREET / KID 200 ALLROAD / ACCESS 200

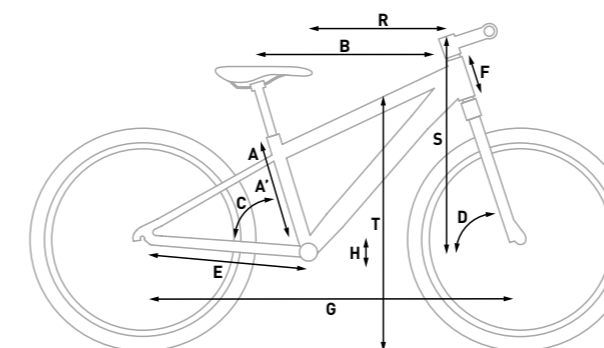

20"	A	A'	B	C	D	E	F	G	H	R	S	T
	258	208	438	73,5	72	374	105	854	-20	314	420	518

LEGEND

- A SEAT TUBE MM
- A' SEAT TUBE CENTER-CENTER MM
- B TOP TUBE HORIZONTAL MM
- C SEAT TUBE DEGREE
- D HEAD TUBE ANGLE DEGREE
- E CHAIN STAYS MM
- F HEAD TUBE MM
- G WHEELSBASE MM
- H BB-HEIGHT TO HUB MM
- I REAR TRAVEL MM
- R REACH MM
- S STACK MM
- T STANDOVER HEIGHT - 80MM FROM THE BB MM

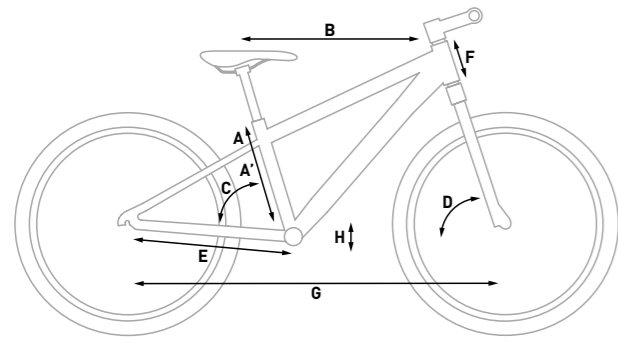

■ KID 240 / ACID 240 / ACCESS 240 / REACTION 240

	A	A'	B	C	D	E	F	G	H
24"	309	259	512	72.4	72	426	108	969	-40

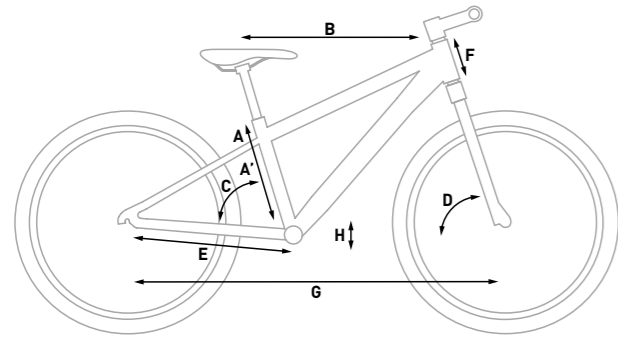

■ ACID 240 ALLROAD / ACCESS 240 ALLROAD

	A	A'	B	C	D	E	F	G	H
24"	309	259	512	72.4	72	426	108	982,7	-40

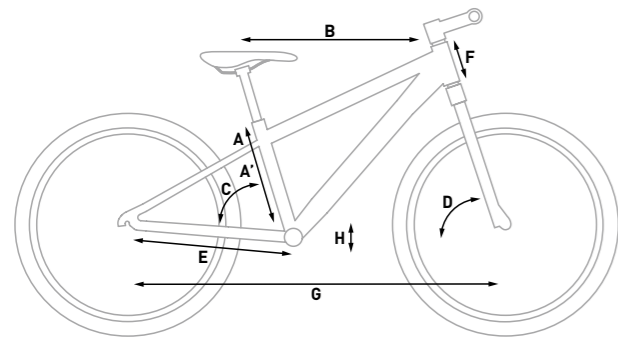

■ ACID 260

	A	A'	B	C	D	E	F	G	H	R	S	T
26"	330	273	535	73,8	69	415	100	1025	46,5	373	559	669

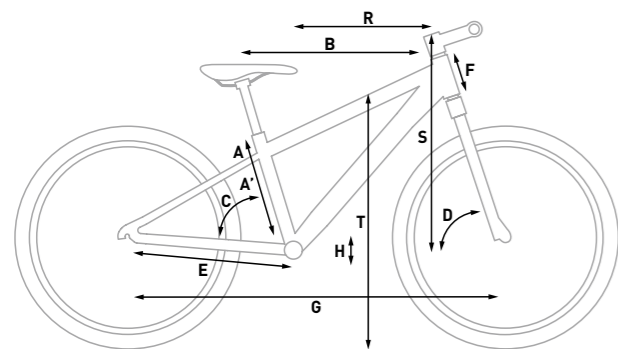

■ KID 240 STREET

	A	A'	B	C	D	E	F	G	H	R	S	T
24"	309	259	523	72.4	72	416	102	973	-40	356	529	616

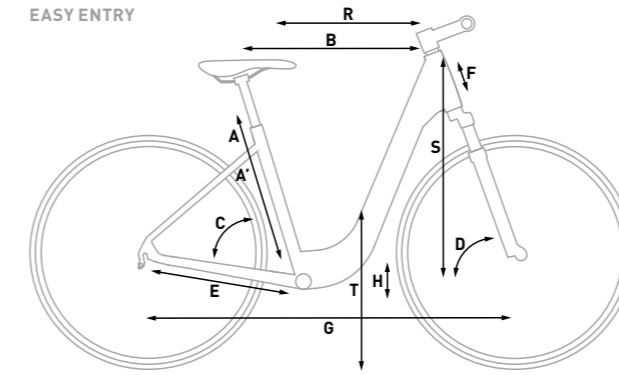

■ ELLA 200

	A	A'	B	C	D	E	F	G	H	R	S	T
20"	300	120	449	73,4	70,5	366	150	876	0	319	435	351

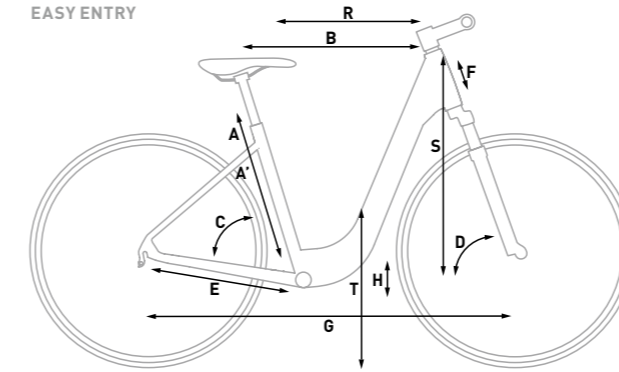

■ ELLA 240

	A	A'	B	C	D	E	F	G	H	R	S	T
24"	350	130	520	72,5	72	416	150	973	-40	354	524	382

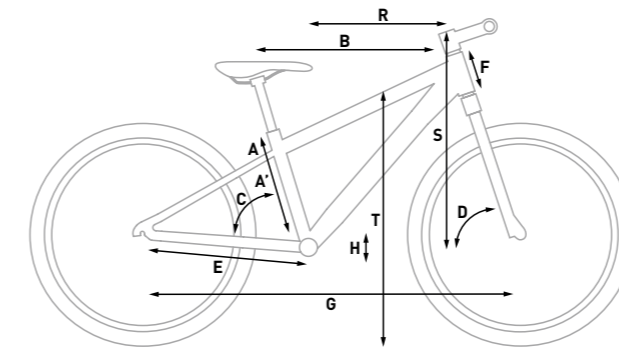

■ REACTION C:62 YOUTH

	A	A'	B	C	D	E	F	G	H	R	S	T
13,5"	355	305	548	73,5	69	410	95	1036	-51,5	379	581	705

	A	A'	B	C	D	E	F	G	H	R	S	T
15"	370	315	567	73,5	69	423	100	1070	-65	389	609	726

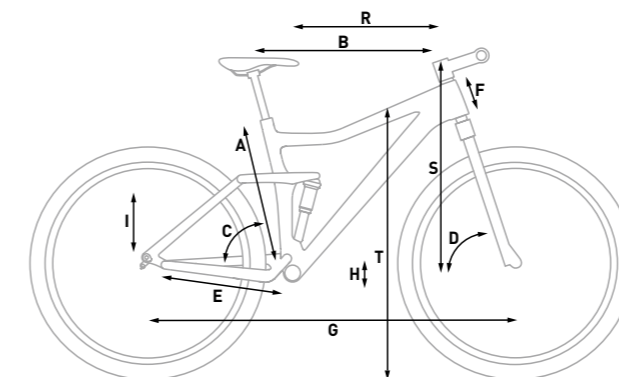

■ STEREO 120 YOUTH

	A	B	C	D	E	F	G	H	I	R	S	T
13,5"	350	547	75,3	67,5	417	120	100	1096	-20	405	567	698,5
16"	360	562	75,3	67,5	417	120	100	1111	-20	420	567	718

LEGEND

A SEAT TUBE MM	E CHAIN STAYS MM	R REACH MM
A' SEAT TUBE CENTER-CENTER MM	F HEAD TUBE MM	S STACK MM
B TOP TUBE HORIZONTAL MM	G WHEELSBASE MM	T STANDOVER HEIGHT - 80MM FROM THE BB MM
C SEAT TUBE DEGREE	H BB-HEIGHT TO HUB MM	
D HEAD TUBE ANGLE DEGREE	I REAR TRAVEL MM	

CUBE BIKES
Ludwig-Hüttner-Straße 5-7
95679 Waldershof
Germany

www.cube.eu

E-Mail: info@cube.eu

CLAUSE RESERVING ERRORS

* All indicated weights are for the pictured bike (middle frame size) without pedals. Deviations are possible.

All images and product descriptions listed are correct at time of press. Despite careful preparation and checking of all data we reserve the right to make changes without notice. Errors cannot be excluded.

RIGHTS OF USE

The rights for all used text, pictures, graphic designs and logos are owned by the company PENDING SYSTEM GmbH & Co. KG. Use is only permitted with the permission of PENDING SYSTEM GmbH & Co. KG. This approval is subject to revocation.





