



**HYBRID** 2020

# CONTENTS/



## HIGHLIGHTS

<b>4</b> CROSS HYBRID SL ALLROAD	<b>6</b> TOURING HYBRID EXC	<b>8</b> KATHMANDU HYBRID SLT	<b>10</b> NURIDE HYBRID SL ALLROAD
<b>12</b> REACTION HYBRID RACE	<b>14</b> REACTION HYBRID SLT	<b>16</b> ELITE HYBRID C:62 SL	<b>18</b> STEREO HYBRID 120 RACE ALLROAD
<b>20</b> STEREO HYBRID 140 HPC SLT	<b>22</b> STEREO HYBRID 160 HPC SLT	<b>24</b> NUROAD HYBRID C:62 SL DISC	<b>26</b> COMPACT HYBRID

<b>HIGHLIGHTS</b>	<b>4</b>
<b>HARDTAIL</b>	<b>38</b>
<b>FULLSUSPENSION</b>	<b>86</b>
<b>ROAD RACE</b>	<b>144</b>
<b>WOMEN'S SERIES</b>	<b>160</b>
<b>TOUR</b>	<b>184</b>
<b>URBAN</b>	<b>234</b>
<b>KIDS</b>	<b>270</b>
<b>GEOMETRY</b>	<b>282</b>



# FOR US —

We love bikes. It's as simple as that! From the first turn of the pedals on the morning commute to a fun after-work loop or battling it out with our rivals in a sweat fest. That's why we build bikes that live up to our expectations 100%, that get our hearts beating in watts, and that we ourselves love to ride. Every single bike in our range is the culmination of our passion and know-how. And that's something that benefits everyone – you and us. New ideas make the world go round, which is why we never stop working on ourselves and on creating the perfect bike. For you, for everyone else, and for us. Because we want the best for everyone.



# + CROSS HYBRID SL ALLROAD



## TECHNOLOGY

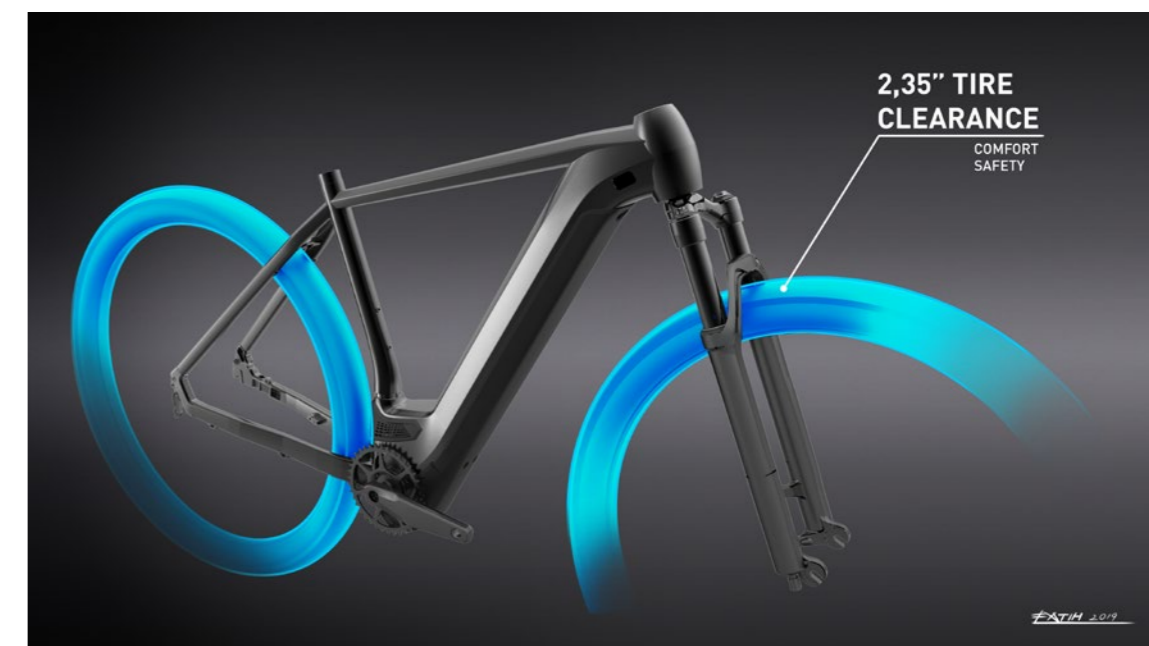

SHIMANO XT 12 SPEED AND ROCKSHOX SUSPENSION  
WITH BOSCH POWER: NO COMPROMISE

**625** WH  
BATTERY

**340%** ASSISTANCE

**60MM** MAX.  
TYRE WIDTH

Why settle for less when you can have so much more? Pretty much everything on the new Cross Hybrid SL is bigger, stronger and wider than you've ever seen before on an all-terrain e-bike: The brand-new Powertube 625Wh battery has more capacity than ever for even longer tours, the huge 340% assistance of the new CX motor delivers more power, and the frame is compatible with ultra-wide 60mm tyres for added comfort, grip and safety.

# + TOURING HYBRID EXC



## TECHNOLOGY

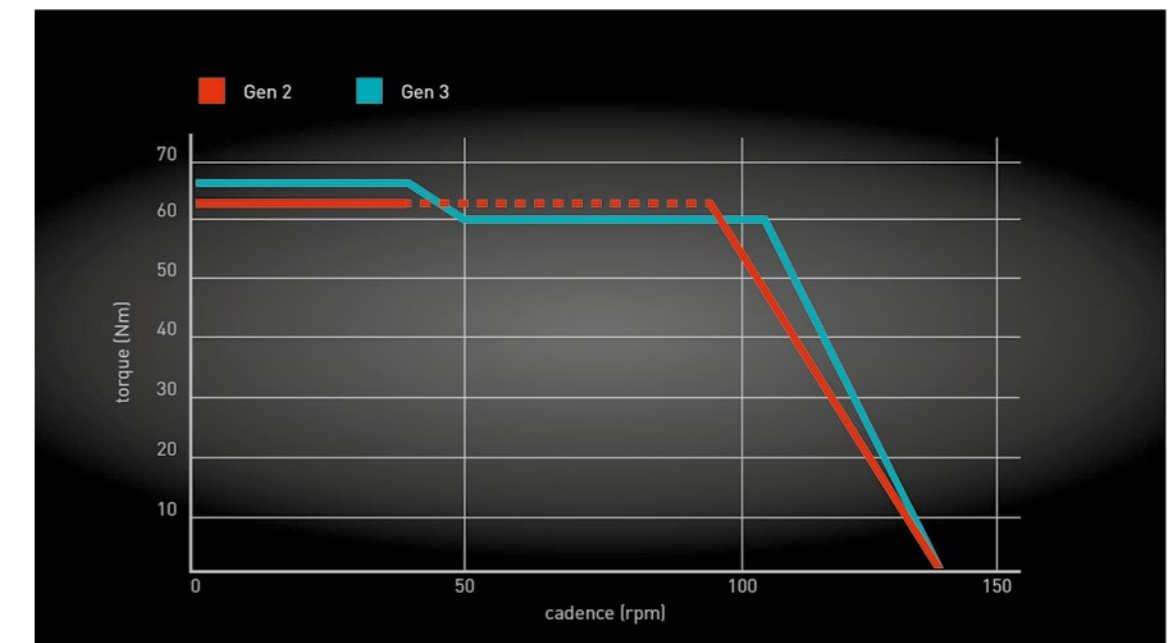

### SHIMANO 11 SPEED RELIABILITY MEETS BOSCH POWER AND URBAN PRACTICALITY

In 2014, the Bosch Performance Line motor went down in the history books: It revolutionised an entire industry and set benchmarks in the sporting e-bike segment in terms of power, lifespan and motor control. Six years later, this success story is still going strong. Following a complete overhaul, the motor is now the quietest on the sports bike market and offers an even bigger performance spectrum. From the first turn of the pedal to high-cadence riding, you can rely on its full support. Another highlight for 2020 is the addition of the unique EMTB mode to the Performance Line motor. This mode delivers an even more harmonious and natural-feeling ride than ever before.

# + KATHMANDU HYBRID SLT



## TECHNOLOGY

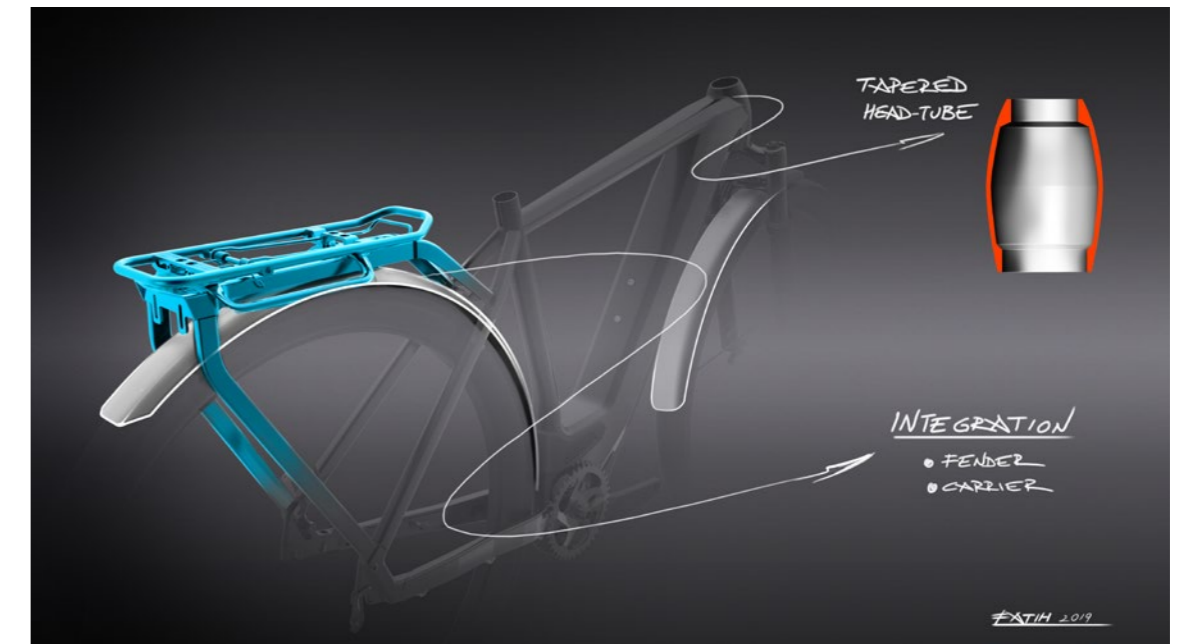

**25kg** 25KG LOAD CAPACITY

**20%** 20% STIFFER

**4 IN 1** RACKTIME SNAPIT, ACID RILINK, RAIL & SPRING CLAMPS

Shimano XT, 12 speed and fourth generation Bosch e-bike power

Complete integration comes high on our list of priorities for e-bikes and the Kathmandu Hybrid SLT sets a shining example. Its brand-new, elegant frame fully encases a powerful Bosch's fourth generation CX drive unit and new CUBE Modular Battery System in a bike that not only looks fantastic but is highly efficient to boot. With an integrated luggage rack, mudguards, lights – including an integrated sidelight with 180 lumen for added visibility – and a practical kickstand, this bike has everything you'll ever need.

# + NURIDE HYBRID SL ALLROAD



## TECHNOLOGY



### SHIMANO XT 12 SPEED, FOX SUSPENSION AND FOURTH GENERATION BOSCH POWER WITH EASY ENTRY MTB VERSATILITY

We love a challenge! So we set the bar unbelievably high when we decided to design a comfortable step-through frame that not only meets all of our tough e-MTB test criteria but also has an open down tube for perfect integration of the new Bosch Powertube 625Wh battery. Following an incredibly extensive analysis phase working in conjunction with a joint task force, we are proud to say we made the impossible possible – and present to you the Nuride Hybrid! A fully-fledged e-MTB with a step-through frame. And even though our in-house tests are far more rigorous than the legal minimum, the Nuride Hybrid passed them with flying colours. It's ready to take on your next challenge!

+ **REACTION HYBRID RACE**



**TECHNOLOGY**



**SHIMANO XT 12 SPEED, ROCKSHOX JUDY SILVER AIR FORK AND BOSCH E-POWER: E-MTB VALUE AND PERFORMANCE**

Smaller, lighter and more efficient with more power than ever. That's the new Bosch CX motor in a nutshell. Achieving this enhanced performance meant designing a sophisticated heat management system. We incorporated the „chimney effect“ to prevent overheating on steep climbs when the motor is under extra load. Heat is transported away from the motor via the process of convection, while the perfectly integrated motor cover offers added protection against bashes.



# + REACTION HYBRID SLT



## TECHNOLOGY

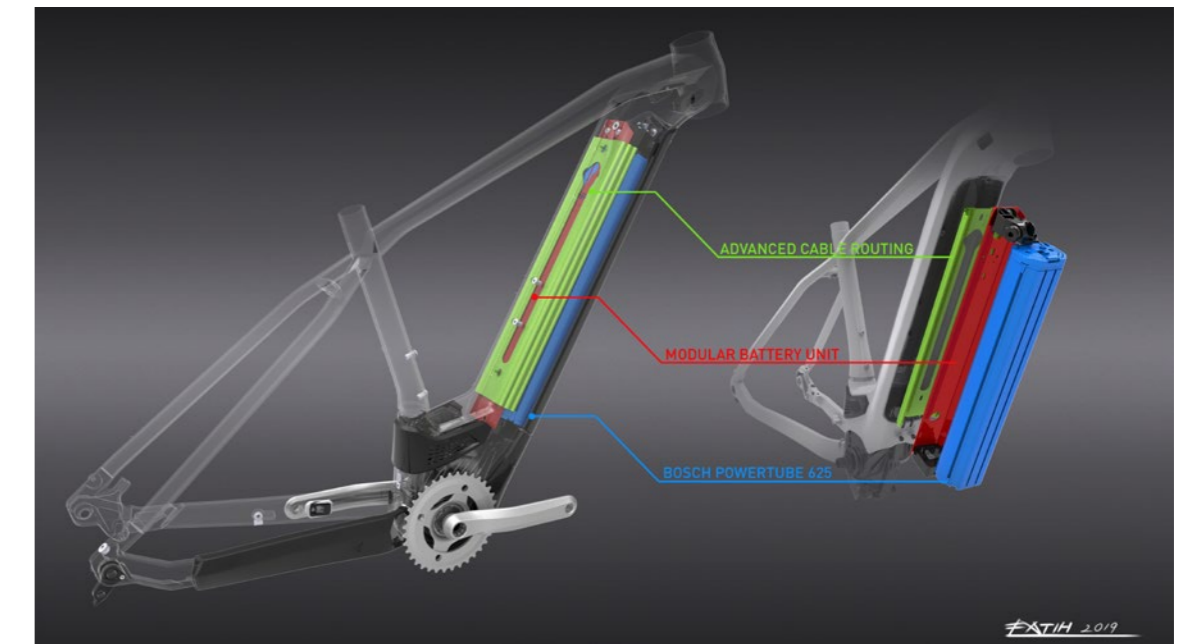

### FOX SUSPENSION, SHIMANO 12 SPEED AND FOURTH GENERATION BOSCH POWER: E-MTB PERFECTION

The new modular battery unit represents a huge milestone in the integration of e-bike battery packs. An extruded rail with CNC-machined bolt mounts makes it a cinch to attach the battery holder with ultimate precision – no special tools needed. And retrofitting a dropper post, running light cables or swapping the display has never been easier courtesy of the new advanced cable routing. Simply remove the battery to access the cable channel and slot the cable outers or cables themselves quickly and easy into the guides as needed.

# + ELITE HYBRID C:62 SL



## TECHNOLOGY

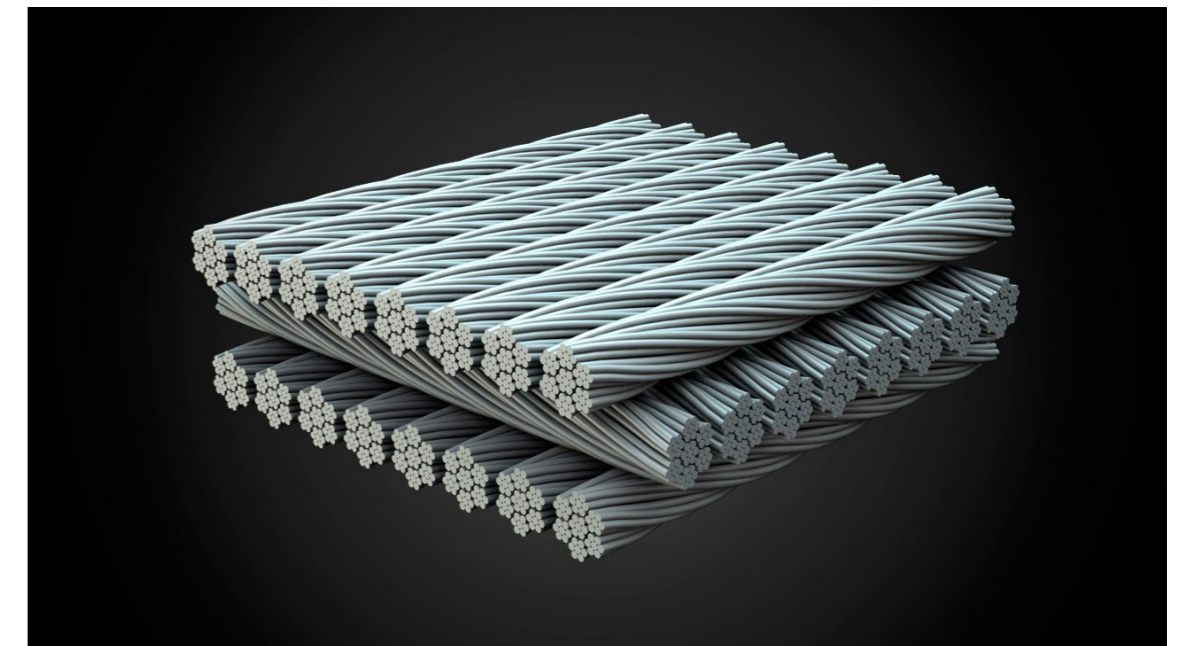

### FOURTH GENERATION BOSCH POWER, CUBE CARBON EXPERTISE AND FOX SUSPENSION - A WORK OF E-MTB ART

There's something uniquely appealing about carbon. With clever application, this exclusive material produces extremely light, stiff and hugely responsive bikes – like the Elite Hybrid C:62 SL! An exceptional combination of individual materials is key to achieving carbon of such high quality: Constructed using the Advanced Twin Mold process, the frame consists of impeccably laid up carbon fibre layers to shave off every last gramme of unnecessary weight. We chose to use high-modulus fibres to make our C:62 frames particularly stiff, while the resin contains finely dispersed nanoparticles for added stability. This lends extra strength to the way the carbon layers are bonded and makes the chassis even less vulnerable to impacts and external forces. E-perfection in carbon form!

# + STEREO HYBRID 120 RACE ALLROAD



## TECHNOLOGY

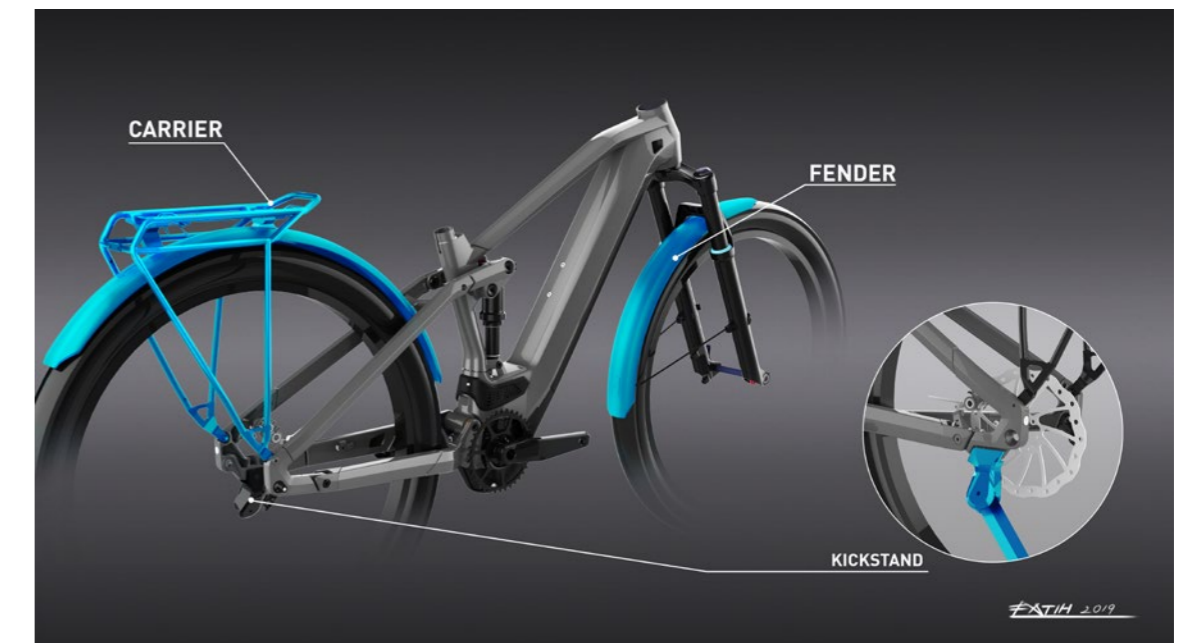

### SHIMANO 12 SPEED, FOX SUSPENSION, BOSCH POWER AND FULL ACCESSORY PACK: THE SWISS ARMY KNIFE OF E-BIKES

Why are SUV models so successful in the automotive industry? We say it's down to the way they combine maximum comfort with sporty looks in a vehicle that's suitable for everyday use. So we took this recipe and applied it to our Stereo Hybrid 120 Race Allroad – completely overhauling it for 2020. The innovative, super-sensitive kinematics work incredibly efficiently, the new design is sportier than ever, and the fully integrated mudguards, kickstands and luggage racks easily make the Stereo Hybrid 120 the perfect combination of daily commuter and off-road adventurer.

# + STEREO HYBRID 140 HPC SLT

Try it, you won't want to go back! These days, a dropper post is just as much an integral part of an all mountain e-bike as the Bosch CX motor or a 4-piston front brake. To make installation and above all fine-tuning even easier and quicker than ever, the cable exits the frame briefly near the bottom bracket. This allows the cable shell to be guided by hand when adjusting the seatpost position, eliminating bunching, folding and stretching.



## TECHNOLOGY

### THE ULTIMATE ALL-MOUNTAIN BOSCH E-BIKE WITH SRAM X01 WIRELESS AXS EAGLE AND ROCKSHOX ULTIMATE SUSPENSION

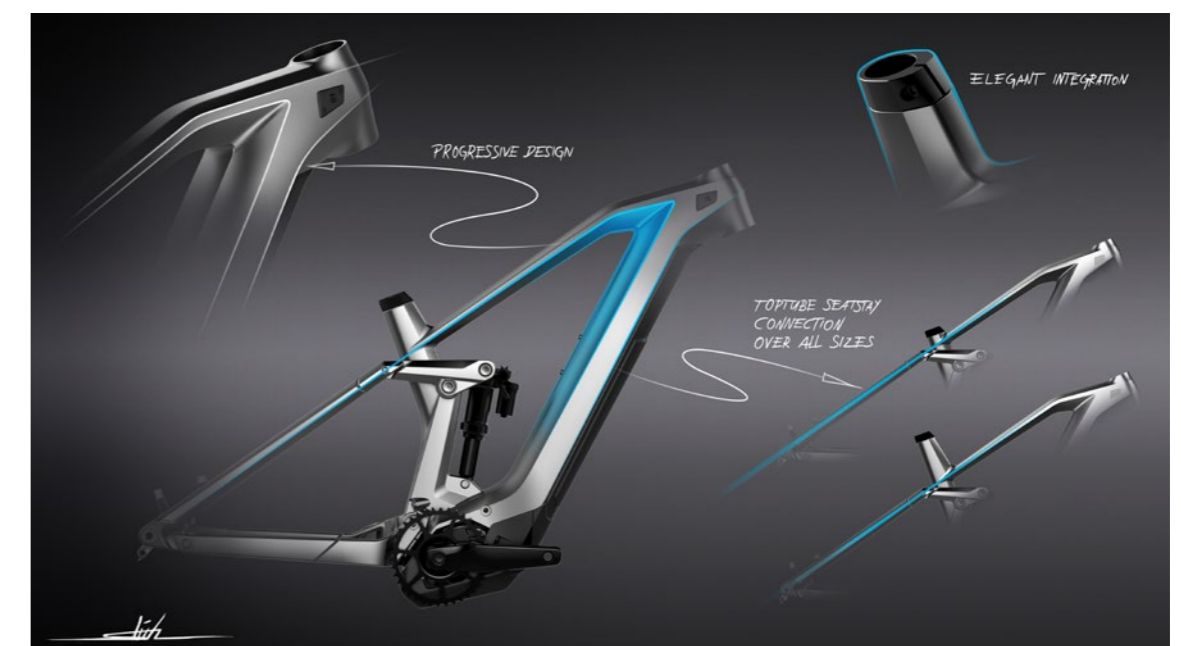

+ **STEREO HYBRID 160**  
HPC SLT



TECHNOLOGY



**PEERLESS ENDURO HYBRID PERFORMANCE WITH WIRELESS SRAM EAGLE 12 SPEED AND ROCKSHOX ULTIMATE SUSPENSION**

100% enduro – not content with countless test wins for its predecessor in big-name bike magazines and top spots in the World E-Bike Series, we've gone and made the Stereo Hybrid 160 27.5 even better! A modern geometry, more progressive kinematics, shorter chain stays, the innovative Bosch CX motor and a high-performance composite frame take this successful model to a whole new level.

# + NUROAD HYBRID C:62 SL

The road ahead isn't always smooth. Luckily, we've thought of that. The new, Fazua-powered Nuroad Hybrid rolls where other road bikes fear to go, harnessing the power of its clever, removable drive system to comfortable Cube geometry. Go explore.



## TECHNOLOGY



**ALLROAD ABILITY, FAZUA E-BIKE VERSATILITY AND CUBE CARBON FRAME CONSTRUCTION: RIDE FURTHER, RIDE MORE, KEEP EXPLORING**

Never stop exploring. With the Nuroad Hybrid C:62 SL Disc, you'll be able to extend your road tours further than ever before. Ride for longer, ride more climbs, keep going when the road ends.... it's the kind of e-bike that'll completely redefine your expectations. Blending the exceptional performance and sleek good looks of a frame constructed from our premium C:62 carbon with the smooth power delivery of Fazua's drive unit and 250Wh battery, it offers a revelatory ride experience. With access to our Advanced Twin Mold manufacturing technique – and the benefit of years of experience producing some of the best e-bikes in the world – our engineering team managed to enclose the removable drive unit and battery completely within the Nuroad Hybrid C:62 SL Disc's elegant down tube. Big days out in big country just got bigger, with no extra effort. Isn't that a win / win?

# + COMPACT HYBRID



## TECHNOLOGY



### URBAN BOSCH E-BIKE POWER WITH SHIMANO 10 SPEED GEARS AND COMPACT DESIGN FOR FUN, FAST AND SAFE RIDING AROUND TOWN

Urban mobility isn't just a marketing slogan to us – we understand the importance of building bikes that can handle the rigours of city life. So that's exactly what we did. We created a new generation of bikes designed with a clear goal in mind: To make daily life easier and turn navigating the city streets into an enjoyable and uncomplicated experience, whether you're commuting to work or popping to the shops. Deciding to leave the car at home has never been easier with our innovative Urban bikes. They're the answer you've been looking for. FOR us #commuters

**T-SHAPE**  
**MORE LEGROOM**  
when pedalling thanks to the svelte design of the saddle tip.

**SHORT-NOSE**  
**GREATER EFFICIENCY**  
courtesy of the overall length and pronounced T-shape which together allow the saddle to be positioned further forward.

Angle – 1.5 degrees

recommended range

**FLEX AREA**  
**MAXIMUM PRESSURE RELIEF**  
for sensitive areas thanks to flex in the saddle shell.

**EXTRA ROOM**  
to make stepping on and off easier.

**WOMEN**  
specific characteristics

**TARGETED PRESSURE RELIEF**  
thanks to an anatomical channel designed around the female form for more precise pressure relief.

**SPECIFIC ADAPTABILITY**  
Women-specific saddles feature slightly higher foam padding for better adaptability to the female muscle anatomy.

**IMPROVED CONTACT AREA**  
Built slightly wider for a contact area better suited to the anatomical differences in the female pelvis.

## SADDLE PORTFOLIO

	APPLICATION	EFFECT
TREKKING	<p><b>SHEN SERIES</b></p> <p><b>COMFORT TOUR TREKKING</b></p> <p><i>Sitz dich Fit</i></p>	<p>The unique Shen series applies the PONS0 ergonomic sitting principle to deliver comfort like never before thanks to a combination of individually shaped foam layers with different properties and a specially contoured saddle shell. Ergonomic channels minimise discomfort around the sit bones and sensitive nerve pathways. These design features work in harmony to distribute load to the muscles instead and also help to reduce friction. The SHEN series is No. 1 in our new comfort standard.</p>
MOUNTAINBIKE	<p><b>SEQUENCE</b></p> <p><b>TOUR TREKKING HYBRID</b></p>	<p>The comfort-oriented SEQUENCE series zeroes in on optimal pressure distribution by deploying large memory foam inserts – ideal for long tours in a slightly bent-forward position. The memory foam inserts extend to the flanks and work with the underlying design to not only deliver noticeably more legroom but also reduce friction on the thighs. The compact design makes getting on and off the bike a cinch. The ideal all-round saddle for comfortable sport-oriented touring.</p>
MOUNTAINBIKE	<p><b>SEQUENCE+</b></p> <p><b>TREKKING HYBRID ALLMOUNTAIN</b></p>	<p>The outstanding comfort of the SEQUENCE series has been taken to the next level with the unique design of the SEQUENCE PLUS models created specially for ambitious riders who don't want to compromise on comfort. The advanced saddle shell design allows the addition of extra foam height despite the streamlined silhouette. Additional legroom comes courtesy of the pronounced T-shape and downward-sloping outer edges. Position the saddle forward for maximum efficiency thanks to the extensive adjustment range – for comfort and performance without compromise.</p>
MOUNTAINBIKE	<p><b>VENEC SERIES</b></p> <p><b>ALLMOUNTAIN MTB</b></p>	<p>Not only do the VENEC saddles come with a super-compliant shell, they also effectively conduct ground vibrations through the rails and away from the rider to make this series a flexible all-rounder for most kinds of bikes and uses. The pronounced anatomical channel with its special design promotes a variety of riding positions for maximum variability. The result? The streamline VENEC series is ideal for use in rougher terrain and where flexibility is king.</p>
ROAD	<p><b>NUANCE SERIES</b></p> <p><b>MTB CROSS COUNTRY ROAD</b></p>	<p>Light weight meets effortless design for pure cycling enjoyment. Designed for an extremely bent-forward and aggressive riding position, the NUANCE SL and SLT series deliver maximum pressure relief for the perineum thanks to cutouts in the underneath of the shell. These saddles are designed specifically to enable fast, powerful pedalling. Similar to other saddles in our range, the overall length and contours promote a more centrally aligned riding position for greater efficiency. The low weight is testimony to the competitive focus of this series.</p>



## RANGE

### + PowerPack 400 / PowerTube 400

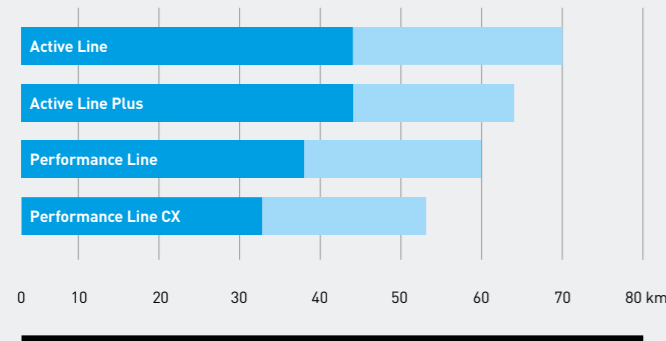

### + PowerPack 500 / PowerTube 500

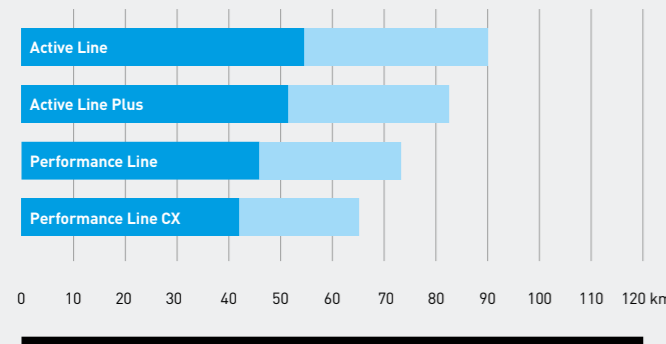

### + PowerTube 625

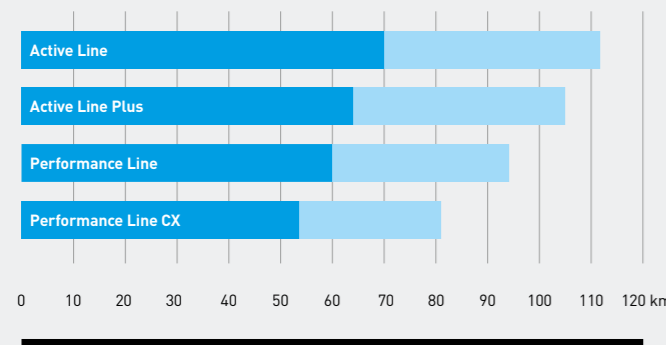

## + RANGE OPTIMIZED

PowerPacks are the fuel tanks of pedelecs. State-of-the-art lithium-ion technology makes them into efficient and longlasting suppliers of power. As an eBiker you can ride with them very conomically and thus maximize the range of a rechargeable battery charge.

### TIRE PRESSURE

Rolling resistance can be minimized by proper tire pressure. Tip: In order to maximize the range, inflate the tires to the maximum permissible tire pressure.

### RECHARGEABLE BATTERY & TEMPERATURE

With decreasing temperature, the efficiency of a rechargeable battery goes down, since the electrical resistance increases. In winter you can thus expect a reduction in the normal range.

### CADENCE

Cadences above 50 revolutions per minute optimise the efficiency of the drive unit. In contrast, very slow pedalling is very costly in terms of energy.

### STARTING & BRAKING

As with a car, frequent starting and stopping is less economical than long distances at a nearly constant speed.

### GEAR SHIFTING

Correct shifting also makes eBiking more efficient. It is best to start off and take inclines in a low gear. You then switch to a higher gear in accordance with the terrain and speed.

## + BATTERIES AND RANGE\*

\* Average of combined use of all four modes and difficult and favorable conditions.

### DIFFICULT CONDITIONS

### FAVORABLE CONDITIONS

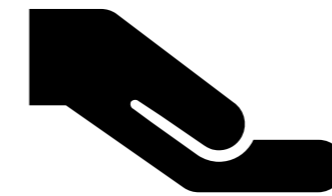

## CARE

### CARE & PROPER TREATMENT

The more conscientiously you treat the PowerPack, the further it will take you.

### CHARGING

The battery should be charged under dry conditions and at room temperature.

### STORAGE DURING WINTER

Store the batteries in a dry location at temperatures between 0 and 20 °C. Storage at room temperature is ideal. Being completely charged or completely discharged for storage is not advised for the batteries. The ideal charge status for lengthy periods of storage is approx. 30 to 60% or two to three LEDs on the battery indicator.

### STORAGE

Temperatures below -10 °C and above 60 °C should be avoided.

### TRANSPORT

For transport, the battery should always be taken off the eBike and safely transported in your car, for example.

### CLEANING & CARE

Cleaning with a direct water jet is impermissible, in particular to protect the electronic components. Before cleaning, remove the battery. Occasionally clean and lightly grease the plug terminals.

### WINTER USE

During winter use (particularly below 0 °C) we recommend charging and storing the battery at room temperature before inserting the battery in the eBike immediately before riding it. For frequent travel in the cold, it is advisable to use thermal protective covers.

### INSPECTION

Using a diagnostic unit, the dealer can check the health status of the eBike, especially the battery, and tell you the number of charging cycles.

## CHARGING TIME QUICKLY AT FULL CHARGE

The charging time depends on the capacity of the battery and of the charger: with the Standard Charger, the PowerPack 300 requires approx. one hour for half a charge, while the PowerPack 400 requires around 1.5 hours and the PowerPack 500 about two hours. An empty PowerPack 300 is fully charged in just 2.5 hours. A PowerPack 400 needs 3.5 hours for this, and the PowerPack 500 4.5 hours. A charge cycle refers to full charge in a single charging session or several partial charging sessions.

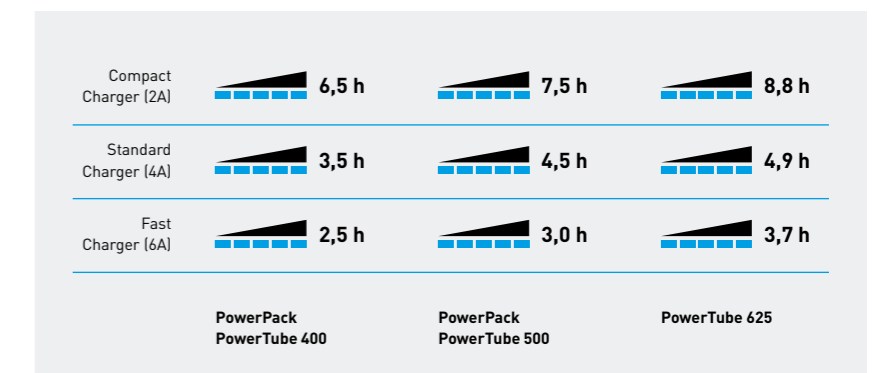

## SERVICE LIFE

The service life of a PowerPack is influenced mainly by the type and duration of use. Like every lithium-ion battery, a PowerPack also ages over time, even if you do not use it.

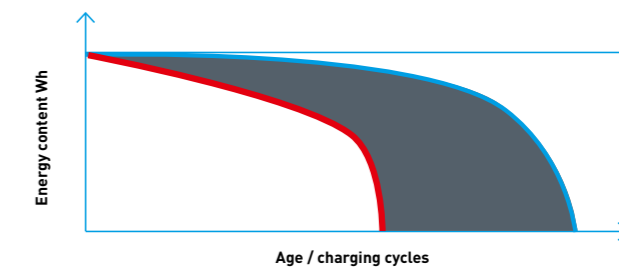

Figure shows typical curves for energy content over usage duration and frequency.



### POSITIVE FACTORS

- Low load
- Storage at a temperature between 0 and 20 °C
- Storage at approx. 30 to 60% charge status



### NEGATIVE FACTORS

- Heavy-duty use
- Storage at over 30 °C ambient temperature
- Prolonged storage in a completely charged or completely discharged state
- Parking of the eBike in the blazing sun

Active Line

AN ELEGANT COMPANION

Whether you need to get to work in the morning or to a restaurant in the evening: Active Line brings the joy back to urban mobility - even in rush hour. Smooth lightweight and quiet, it is the ideal way to get around town. Its controlled acceleration with barely detectable pedal resistance at over 25 km/h or when switched off turns every trip into an experience, as well as making an elegant statement: the design is a recipient of the Red Dot Design Award. The drive unit integrates perfectly into the bike frame, making handling and life just that little bit easier, thanks to the light weight.



+ ACTIVE LINE (25 km/h)

EAR TYPE	HUB GEAR SYSTEM	DERAILLEUR SYSTEM
SUPPORT LEVEL (%)	Turbo: 250	Turbo: 250
	Sport: 170	Sport: 170
	Tour: 100	Tour: 100
	Eco: 40	Eco: 40
MAXIMUM POSSIBLE DRIVE TORQUE (NM)	Turbo: 40	Turbo: 40
	Sport: 38	Sport: 38
	Tour: 35	Tour: 35
	Eco: 30	Eco: 30
SUPPORT UP TO MAXIMUM CADENCE (RPM)	>100	
START-UP BEHAVIOUR	Harmonious	
WEIGHT	ca. 2,9 kg	

Active Line Plus

THE EASY WAY TO ACHIEVE NEW EXPERIENCES

The desire for new discoveries knows no bounds. Active Line Plus brings mobility to everyday life and extends your options for spontaneous excursions. The quiet, small yet powerful drive unit offers a major advantage in riding enjoyment. Lightweight and compact, it allows agile handling and fits perfectly inside the frame. No disturbing extraneous noises and almost no pedal resistance over 25 km/h - new experiences and discoveries await you.



+ ACTIVE LINE PLUS (25 km/h)

EAR TYPE	HUB GEAR SYSTEM	DERAILLEUR SYSTEM
SUPPORT LEVEL (%)	Turbo: 250	Turbo: 270
	Sport: 170	Sport: 180
	Tour: 100	Tour: 100
	Eco: 40	Eco: 40
MAXIMUM POSSIBLE DRIVE TORQUE (NM)	Turbo: 50	Turbo: 50
	Sport: 45	Sport: 45
	Tour: 40	Tour: 40
	Eco: 35	Eco: 35
SUPPORT UP TO MAXIMUM CADENCE (RPM)	>105	
START-UP BEHAVIOUR	Harmonious agile	
WEIGHT	ca. 3,2 kg	

Performance Line

THE EBIKE BECOMES SPORTY

The new Performance Line is the most versatile drive system from Bosch. Whether you're on a sporty jaunt through the countryside, commuting to work or cruising on a leisurely outing, it always delivers the right support at the right moment. There are two variants. The quiet, lightweight Drive Unit Performance Line Cruise provides support up to 25 km/h and offers a convincingly natural sporty riding sensation. With a torque of 65 Nm, it also helps riders get the most out of outings in mountain terrain. The Performance Line Speed speeds up daily routines with even more power and supports S-Pedelecs with a torque of up to 75 Nm and up to 45 km/h. It enables high speeds to be reached quickly and long distances no longer pose a challenge.



+ PERFORMANCE LINE (25 km/h)

EAR TYPE	HUB GEAR SYSTEM	DERAILLEUR SYSTEM
SUPPORT LEVEL (%)	Turbo: 300	Turbo: 300
	Sport: 200	Sport/eMTB: 120-300
	Tour: 120	Tour: 120
	Eco: 55	Eco: 55
MAXIMUM POSSIBLE DRIVE TORQUE (NM)	Turbo: 65	Turbo: 65
	Sport: 50	Sport: 60
	Tour: 45	Tour: 45
	Eco: 35	Eco: 35
SUPPORT UP TO MAXIMUM CADENCE (RPM)	>120	
START-UP BEHAVIOUR	Dynamic	Sporty
WEIGHT	ca. 3,2 kg	

RIDING MODES

The Bosch eBike system provides five different riding modes to choose from, offering the ideal support profile depending on the application and rider type.



TURBO

Direct, powerful support up to maximum cadence for sportive riding



SPORT / EMTB\*

Immediate, powerful support for athletic riding off-road and in city traffic



TOUR

Steady support for long tours



ECO

Effective support at maximum efficiency for maximum range



OFF

No support, all on-board computer functions are available

\* The eMTB Mode, which is specially conceived for the Performance Line CX, dynamically switches between the Tour and Turbo riding modes, offering progressive motor support for maximum performance on the trail.

Performance Line CX

A NEW ERA FOR EMOUNTAIN BIKERS

No path too steep, no challenge too great: the new Performance Line CX is made for anyone for whom the trail is a second home. The most powerful drive from Bosch for ambitious riders is particularly lightweight and compact and has minimal pedal resistance. In eMTB Mode, the rider receives the required power at precisely the right moment. The Performance Line CX accelerates extremely powerfully, responds without delay and features convincing agile handling and even more control. With up to 340% of perfectly delivered support, it pushes the joy of eMountain biking to the max.



+ PERFORMANCE LINE CX (25 km/h)

EAR TYPE	DERAILLEUR SYSTEM
SUPPORT LEVEL (%)	Turbo: 340
	eMTB*: 140-340
	Tour: 140
	Eco: 60
MAXIMUM POSSIBLE DRIVE TORQUE (NM)	Turbo: 75
	Sport: 75
	Tour: 50
	Eco: 40
SUPPORT UP TO MAXIMUM CADENCE (RPM)	>120
START-UP BEHAVIOUR	Very sporty
WEIGHT	ca. 2,9 kg

## SPORTY AND NATURAL.

With a sporty torque of 65 Nm and high performance, the drive unit always provides the right support at the right moment, even in the mountains. The riding sensation remains natural with almost no pedal resistance when switched off and at over 25 km/h. Easy and silent support - for maximum riding pleasure.



### PERFECT INTERPLAY

A cohesive riding experience: the multi-sensor concept and fast information processing ensures optimum interaction between riders and their eBikes.

### QUIET ENJOYMENT

This is what riding enjoyment sounds like: the innovative noiseoptimised gearbox makes the Performance Line 25 km/h one of the quietest drives in its class.

### READY FOR ANY ADVENTURE

Whatever you're planning: five riding modes make every ride a pleasure. eMTB mode, which is only used on eMountain bikes, also delivers for off-road adventures in a controlled and comfortable way.



#### MAX. TORQUE

It facilitates sporty acceleration even in high cadences.



#### MAX. SUPPORT

Dynamic, ideal for extended sporty rides.

## STRONG SUPPORT.

The Drive Unit Performance Line CX is the powerhouse among the drives. Weighing 2.9 kg and with a maximum torque of 75 Nm, it brings more riding enjoyment to the trail on demanding rides despite its particularly compact size. The eMountain bike motor with the innovative new gearbox conquers every terrain - offering precise response, sporty agility and fast sprints.



### COMPLETE CONTROL

Ready for every terrain: in eMTB mode, the progressive motor support automatically adapts to the individual's riding style. This prepares the bike for whatever the terrain may have to throw at it, without even having to change gear. The rider thus benefits from significantly better traction.

### PERFECT MOTOR CONTROL

Sporty riding enjoyment: the multi-sensor concept enables a dynamic and responsive drive unit response for precise acceleration and a unique trail experience.

### COMPACT CONSTRUCTION

Highly adaptable: weighing just 2.9 kg and with a size reduced by 48%, the new drive sets new standards. This allows different frame geometries with shorter chain stays and optimal integration, making eMountain bikes much more nimble and agile.

### DIRECT POWER TRANSMISSION

Always full performance: the motor ensures powerful riding behaviour right from the start. The drive delivers constant power over a very wide cadence range - perfect for fast intermediate sprints and crisp changes of tempo.

### ROBUST AND RELIABLE

Made for off-road terrain: the drive will meet the highest eMountain bike requirements and will withstand even extreme loads. Even on long mountain rides, the motor offers impressive performance.



#### MAXIMUM MOMENTUM

Powerful acceleration despite compact size.



#### MAX. SUPPORT

For powerful acceleration, an extremely sporty riding style and fast sprints.



#### DRIVE UNIT

Sustained support up to 25 km/h, even on long mountain rides.

### MINIMAL PEDAL RESISTANCE

The new gearbox concept significantly reduces pedalling resistance when the drive is switched off and at over 25 km/h, so the rider benefits from a natural riding sensation.

### PERFECT SUPPORT

For alpine terrain: with eMTB mode, powerful walk assistance and support for short cranks, Bosch offers eMountain bikers a perfect combination for challenging uphill sections and demanding mountain trails.

## INTUVIA

CLEVER AND CLEARLY ARRANGED.



### INTUITIVE CONTROL CENTRE

Intuvia guarantees easy and intuitive control of your eBike. The display is easy to read in any situation and shows you all the important information.

### MAXIMUM EASE OF USE

Easy operation via the separate control unit.

### IDEAL FOR TRAVELING

Even when removed from the eBike, all important information, such as the total distance, can be called up.

### GOOD READABILITY

Under all lighting conditions, exemplary ergonomics and ergonomic handling.

## PURION

COMPACT PURIST.



### COMPACT AND CLEARLY ARRANGED

Design meets functionality: Purion is a minimalist on-board computer designed for anyone who wishes to focus on the most important information and prefers an uncluttered handlebar. Suitable for use in the city and countryside. You can focus on the essentials and get all important information at a click of your thumb, while keeping your hands on the handlebars throughout your trip. Five different riding modes give you just the right amount of assistance in every situation.

### CLEARLY ARRANGED DISPLAY

Charge status, speed, riding mode, range, trip distance and total distance.

### GOOD READABILITY

The backlit non-glare display allows you to read all riding data clearly.

## KIOX

SMALL DISPLAY, GREAT PERFORMANCE.

Small, robust and connected: Kiox is the on-board computer for ambitious sporty riders. Kiox has all the classic functions of an on-board computer, while at the same time giving the eBiker access to the digital world via the smartphone app. The colour display gives you all riding data at a glance, while the separate control unit allows you to stay in control of the handlebars and keep an eye on the terrain. Kiox can record your trips and send all the relevant data via the smartphone's Bluetooth connection to the eBike Connect online portal. This makes Kiox the perfect companion on every ride.



### + NEW KIOX-FEATURES

#### CONNECTIVITY

The sporty display is the connection to the networked eBike world of Bosch. All relevant riding data is recorded by Kiox and transmitted via Bluetooth to the eBike Connect app. The app records GPS data; this information is combined with the riding data - for an overview and analysis of all activities after the trip in the app or in the online portal.

#### AUTOMATIC SYNCHRONISATION

All information at your fingertips at all times: Data is automatically synchronised by Bluetooth between Kiox and the app. Even software updates can be loaded comfortably and wirelessly on the on-board computer.

#### UNBREAKABLE GLASS

Dirt or stone chippings hold no fear: the scratch-resistant glass display make this the ideal partner both off road and in the city.

#### MAGNETIC HOLDER

Quick stowed and safely mounted to withstand off-road jumps: the magnetic holder allows for easy removal and attachment of the onboard computer, as well as a firm hold.

### KIOX AND LOCK

For routine relaxation with the eBike: the new premium function, 'Lock', makes Kiox the key to greater safety. The function enables motor support to be deactivated by removing the on-board computer. Only by attaching the same on-board computer, the lock automatically unlocks again. The clever addition to a mechanical lock - now available for Kiox at an additional charge.

#### FUNCTIONALITY

- When Lock is activated, the eBike can no longer be ridden with motor support
- Lock is the perfect supplement to a mechanical lock
- Lock can only be deactivated with the on-board computer fitted, rendering theft pointless



#### ACTIVATION

- Lock is activated and deactivated by attaching and detaching the Kiox on-board computer
- Audible feedback indicates that the lock has been activated or deactivated
- The status of the Lock is displayed on the screen of the on-board computer

#### COMPATIBILITY

- Bosch eBike Lock is compatible with the Drive Units of the third (Active Line, Active Line Plus, new Performance Line) and fourth generation (Performance Line Speed, Cargo Line, Cargo Line Speed, Performance Line CX)
- Bosch eBike Lock can be used with the Kiox on-board computer

# HARD TAIL



COMMUTING  
TOUR  
SPORT  
ALP CROSS

	COMMUTING	TOUR	SPORT	ALP CROSS
040 ELITE C:62   29				
046 REACTION HPA   27.5, 29				
068 NURIDE HPA				
080 ACID HPA   29				

**ELITE**

No compromise. The new, fourth generation Bosch-powered Elite Hybrid takes your preconceptions of what a hybrid hardtail looks like and throws them off the nearest cliff. Sleek and blisteringly fast, this is the pedal assist hardtail by which all others will be judged.

**REACTION**

If there's somewhere you can't take the new Reaction Hybrid, we haven't come across it yet. Blending the agility, easy handling and ruggedness of our Reaction hardtails with the power of the smooth, beautifully integrated fourth generation Bosch drive unit, it's a tough act to follow.

**NURIDE**

Accessible, comfortable, versatile, go-anywhere fun: that's the essence of the Nuride Hybrid. Built around a brand new Easy Entry frame and Bosch's fourth generation power, it takes all our experience of building great hybrid mountain bikes and just makes it that little bit... easier. Go. Explore.

**ACID**

Simple. Adaptable. Dependable. The Acid Hybrid takes go-anywhere practicality and wraps it up in a sleek, affordable and easy-to-live-with package. Ride to work or take to the hills, it's all the same to this versatile e-bike and its advanced Bosch drive system. Power, on tap.

---

## FOR us #Innovators

---

Progress never stops. We understand that, and so do our partners at Bosch. When they developed their smooth, powerful fourth-generation drive system, we knew we needed an Elite C:62 Hybrid frame capable of doing it justice. The great thing about our Advanced Twin Mold manufacturing technique – and our years of working with carbon – is that it enables us to build a frame to our precise requirements, whatever those might be. And so we started from scratch, developing an all-new Modular Battery System to enable the Bosch power unit to be housed entirely inside the down tube, under its own easy-access cover. There are three benefits to this approach. First, it looks great – a result we reinforced by routing all cables internally for a sleeker appearance and lower maintenance. Second, it allows room for a bottle cage mount. And third, there's enough space inside the new down tube for a higher capacity battery, resulting in even greater range than before. The 1.5in head tube with semi-integrated headset and Boost rear axle work together to transfer the Bosch drive unit's power efficiently to the rear wheel. And Agile Ride Geometry, adjusted to work perfectly with a 120mm fork, means that the Elite C:62 Hybrid is exactly the right blend of lively and stable, almost as though it can read your mind. There's even scope for an easy stealth dropper post upgrade, and we included a kickstand mount because, well, because you never know. Did we think of everything? We think so, but we'll let you be the judge.



# ELITE HYBRID C:62 SL 29

carbon'n'blue



There aren't many bikes that manage to be both a high-performance riding machine and a desirable design object in their own right, but with the Elite Hybrid SL our design team has pulled off this rare feat. Wish-list components are just part of the story. Bosch's fourth-generation CX drive unit and Kiox controller, driven by the extra-high-capacity power unit enabled by our new CUBE Modular Battery System, meshes seamlessly and quietly with Shimano's superb XT transmission to deliver power to the Newmen rear wheel with Shimano XT hub and 2.35in Schwalbe Nobby Nic via a wide-ranging 10-51T cassette. Up front, a Fox 34 Float SC Performance fork has 120mm of easily adjustable and incredibly plush bump-swallowing travel, whilst powerful Shimano XT hydraulic disc brakes ensure you're always in full control. So far, so good. But what makes the Elite Hybrid C:62 SL really stand out is the chassis onto which all this finely engineered bicycle goodness is bolted. Because, starting from scratch and with a drive to build the best possible carbon e-MTB frame, CUBE's engineers created a masterpiece. From the neatly integrated battery to the semi-integrated seat clamp and stiffness-enhancing Boost rear end, the extent of their attention to detail is disguised by clean lines that are so neat, you may even forget you're riding an e-bike. Revised Agile Ride Geometry, dropper post compatibility and looks to die for are all part of the package. Great looks, superb riding and incredible functionality, all rolled into one. Truly, a work of art... even if we do say so ourselves.

- ★ **334552** Cube Elite Hybrid C:62 SL 625 29 carbon'n'blue 2020

---

-  **FRAME**#62 Monocoque Advanced Twin Mold Technology, Boost 148, 1.5 Headtube, Full Integrated Battery, Kickstand Mounting Points  
**SIZE**#7", 19", 21", 23"  
**FORK**#Fox 34 Float Step-Cast FIT GRIP 3-Position Damper, Tapered, 15x110mm, E-Bike Tune, 120mm

---

-  **DRIVE UNIT**#Bosch Drive Unit Performance CX Generation 4 (75Nm) Cruise (250Watt)  
**BATTERY**#Bosch PowerTube 625  
**DISPLAY**#Bosch Kiox  
**CHARGER**#Bosch 4A

---

-  **HEADSET**#SA Orbit Z 1.5E ZS, Top Zero-Stack 1 1/2" (OD 56mm), Bottom Zero-Stack 1 1/2" (OD 56mm)  
**STEM**#Newmen Evolution 318.4, 31.8mm  
**HANDLEBAR**#Newmen Evolution 318.20, 760mm  
**GRIPS**#CUBE Race Grip 31mm, 1-Clamp  
**REAR DERAILLEUR**#Shimano XT RD-M8100-SGS, ShadowPlus, 12-Speed  
**SHIFTERS**#Shimano XT SL-M8100-IR, Direct Attach  
**BRAKE SYSTEM**#Shimano XT BR-M8120, Hydr. Disc Brake (203/180)  
**CRANKSET**#thirteen Plus Crank, 38T, 175mm  
**CASSETTE**#Shimano XT CS-M8100, 10-51T  
**CHAIN**#Shimano XT CN-M8100  
**RIMS**#Newmen Evolution SL A.30, 28H, Disc, Tubeless Ready  
**FRONT HUB**#Shimano XT HB-M8110-B, 15QR, Boost, Centerlock  
**REAR HUB**#Shimano XT FH-M8110-B, 12mm, Boost, Centerlock  
**TYRES**#Schwalbe Nobby Nic, Addix Speedgrip, Kevlar, Tubeless Easy, 2.35  
**SADDLE**#Natural Fit Venec  
**SEAT POST**#Newmen Evolution, 30.9mm  
**SEATCLAMP**#CUBE Varioclose Semi Integrated, 34.9mm

---

-  **WEIGHT**#9.6 kg



**17089**  
CUBE SHOES MTB C:62 SLT

**11074**  
CUBE BLACKLINE BAGGY SHORTS

**14241**  
CUBE HELMET BADGER

-  **SPARE PARTS**#
- 8000** CUBE Headset Orbit Z 1.5E ZS
- 8651** CUBE HANGER\_mtb-x12-std-2020 (18-05516)

# ELITE HYBRID C:62 RACE 29

grey'n'orange



There's an undeniable allure to carbon fibre. Used properly, it can be used to build a fast, sleek and agile bike. Which is exactly what we've done with the Elite Hybrid C:62 Race, except with the added benefit of Bosch's fourth-generation CX drive unit for smooth, quiet power delivery. Add a selection of premium components and revised Agile Ride Geometry for fast, safe and assured handling in any off-road situation, and it adds up to a compellingly well-equipped Bosch e-MTB. Taking inspiration from the superb Reaction Hybrid hardtail chassis, our engineering team applied the same principles with our C:62 carbon and Advanced Twin Mold manufacturing process to build a superbly light, stiff and agile frame. The fully enclosed, high-capacity CUBE modular battery is safely concealed away from dust, dirt and water, and offers even greater range than before. And the svelte, elegant lines conceal neat touches like a semi-integrated seat clamp, integrated cable routing and compatibility with a stealth dropper post. Sounds good, right? Now add the assured performance and easy adjustability of the RockShox Recon Gold fork, serving up 120mm of trail-smoothing travel. Throw in Newmen Evolution cockpit components, 2.35in Schwalbe tyres for epic quantities of grip, Magura's powerful MT Thirty hydraulic disc brakes with 203mm front rotor for safe, predictable stopping in all weathers, and Sram's smooth and reliable 12-speed GX and NX Eagle transmission components. Combined with the Kiox-controlled Bosch CX drive unit, it translates into a superbly competent, extremely fast and surprisingly light trail-devouring machine. Quite frankly, carbon e-mountain biking has never looked so attractive.

★ **334502** Cube Elite Hybrid C:62 Race 625 29 grey'n'orange 2020

**FRAME** #C:62 Monocoque Advanced Twin Mold Technology, Boost 148, 1.5 Headtube, Full Integrated Battery, Kickstand Mounting Points  
**SIZE** #7", 19", 21", 23"  
**FORK** #RockShox Recon Gold RL Air, Tapered, 15x110mm, eMTB Approved, 120mm

**DRIVE UNIT** #Bosch Drive Unit Performance CX Generation 4 (75Nm) Cruise (250Watt)  
**BATTERY** #Bosch PowerTube 625  
**DISPLAY** #Bosch Kiox  
**CHARGER** #Bosch 2A

**HEADSET** #SA Orbit Z 1.5E ZS, Top Zero-Stack 1 1/2" (OD 56mm), Bottom Zero-Stack 1 1/2" (OD 56mm)  
**STEM** #Newmen Evolution 318.4, 31.8mm  
**HANDLEBAR** #Newmen Evolution 318.20, 760mm  
**GRIPS** #CUBE Race Grip 31mm, 1-Clamp  
**REAR DERAILLEUR** #Sram GX Eagle™, 12-Speed  
**SHIFTERS** #Sram NX Eagle™ Trigger, Single Click  
**BRAKE SYSTEM** #Magura MT Thirty, Hydr. Disc Brake (203/180)  
**CRANKSET** #\*thirteen Plus Crank, 38T, 175mm  
**CASSETTE** #Sram XG-1275, 10-50T  
**CHAIN** #Sram GX Eagle™  
**WHEELSET** #Fulcrum Red 55 Boost, 28/28 Spokes, 15x110mm/12x148mm, Tubeless Ready  
**TYRES** #Schwalbe Nobby Nic, Addix Speedgrip, Kevlar, Tubeless Easy, 2.35  
**SADDLE** #Natural Fit Venec  
**SEAT POST** #Newmen Evolution, 30.9mm  
**SEATCLAMP** #CUBE Varioclose Semi Integrated, 34.9mm

**WEIGHT** #9.9 kg

**SPARE PARTS**  
**8000** CUBE Headset Orbit Z 1.5E ZS  
**8651** CUBE HANGER\_mtb-x12-std-2020 (18-05516)



**12117**  
CUBE BACKPACK EDGE TRAIL X ACTIONTEAM

**10708**  
CUBE AM JERSEY

**17072**  
CUBE SHOES MTB PEAK



---

## FOR us #Mountainbikers

---

CUBE's dedicated engineering team is never satisfied. For the brand-new Reaction Hybrid 29 – powered by Bosch's fourth-generation drive system – they went back to the drawing board with a clean sheet of paper and a simple mission: to build the best possible hybrid hardtail frame. Starting with the new Modular Battery System, they designed a new gravity cast down tube to completely enclose the Bosch power unit under an easily accessed cover. It doesn't just look great, it also frees up enough space for bottle cage bosses and the option of a larger capacity battery for even more range. Oversized chain stays, an X12 Boost rear axle and 1.5in head tube work together to transfer the smooth, powerful Bosch drive unit's torque to the rear wheel. Our widely acclaimed Agile Ride Geometry is tweaked and refined to work brilliantly with a 120mm fork, giving handling that builds confidence when you need it and delivers inspiration when you want it. Internal cable routing – including provision for a stealth dropper post upgrade – complements the frame's svelte looks, and we even designed a trapeze version. Add it all up and it's clear to see: there's a Reaction Hybrid 29 with your name on it.



# REACTION HYBRID SLT 29

black'n'grey



# REACTION HYBRID SLT 29

grey'n'yellow



93067  
ACID LED-LICHT HPA 2000

10717  
CUBE AM JERSEY

14252  
CUBE HELMET ROOK

Make no mistake about it – the Reaction Hybrid SLT represents the state of the art in aluminium e-MTB technology. Completely reworked and redesigned for 2020, we're as proud about this Bosch e-bike member of the CUBE family as we are of all our range-topping SLT models. And you don't have to look far to see why. The smooth, elegant lines of the aluminium tubes disguise a wealth of clever design and engineering details. Key to this bike's success is the new CUBE Modular Battery System, which encloses a new, higher-capacity battery entirely within the gravity cast down tube, where it's protected from dust, dirt and water. The custom motor housing provides a stable, secure platform for the fourth-generation Bosch drive unit, while a Boost rear axle, oversized seat stays and rigid 1.5in head tube all combine to ensure that it can deliver its smooth, quiet power to the rear wheel as efficiently as possible. Stealth dropper post compatibility, revised Agile Ride Geometry and chain stay protection with integrated cable routing are the icing on the proverbial cake. Of course, all our SLT models are only as good as the components we fit to them – which is why we chose only the best for the Reaction Hybrid SLT. The Fox 34 Rhythm fork, combined with 2.6in Schwalbe tyres, serves up 120mm of rock- and root-swallowing travel to smooth your path forward, whilst a transmission comprising Shimano's new XT and SLX 12-speed components means you've got slick, reliable shifting over the widest possible gear range – and powerful Shimano hydraulic disc brakes with an oversized 203mm rotor at the front gives you the power you'll need to stop safely, come rain or shine. It really is fully equipped to take on any challenge. Which only leaves one question: where will you be riding tomorrow?

- ★ 334412 Cube Reaction Hybrid SLT 625 29 grey'n'yellow 2020
- 334402 Cube Reaction Hybrid SLT 625 29 black'n'grey 2020

**FRAME** Aluminium Superlite, Gravity Casting, Agile Ride Geometry, 1.5 Headtube, Boost 148, Internal Cable Routing, Full Integrated Battery, Kickstand/Fender/Carrier Mounting Points  
**SIZE** 5", 17", 19", 21", 23"  
**FORK** Fox 34 Rhythm, 2-Position Sweep-Adjust GRIP Damper, Tapered, 15x110mm, E-Bike Optimized, 120mm

**DRIVE UNIT** Bosch Drive Unit Performance CX Generation 4 (75Nm) Cruise (250Watt)  
**BATTERY** Bosch PowerTube 625  
**DISPLAY** Bosch Kiox  
**CHARGER** Bosch 4A

**HEADSET** SA Orbit Z 1.5E ZS, Top Zero-Stack 1 1/2" (OD 56mm), Bottom Zero-Stack 1 1/2" (OD 56mm)  
**STEM** CUBE Performance Stem, 31.8mm  
**HANDLEBAR** Newmen Evolution 318.10, 720mm  
**GRIPS** CUBE Race Grip 31mm, 1-Clamp  
**REAR DERAILLEUR** Shimano XT RD-M8100-SGS, ShadowPlus, 12-Speed  
**SHIFTERS** Shimano SLX SL-M7100-I Direct Attach  
**BRAKE SYSTEM** Shimano XT BR-M8120, Hydr, Disc Brake (203/180)  
**CRANKSET** Thirteen Plus Crank, 38T, 175mm  
**CASSETTE** Shimano SLX CS-M7100, 10-51T  
**CHAIN** Shimano SLX CN-M7100  
**RIMS** CUBE EX30, 32H, Disc, Tubeless Ready  
**FRONT HUB** Shimano HB-MT400-B, 15mm, Boost, Centerlock  
**REAR HUB** Shimano FH-MT510-B, 12mm, Boost, Centerlock  
**TYRES** Schwalbe Smart Sam, Performance, Kevlar, 2.60  
**PEDALS** CUBE PP MTB  
**SADDLE** Natural Fit Sequence+  
**SEAT POST** CUBE Performance Post, 30.9mm  
**SEATCLAMP** CUBE Varioclose, 34.9mm

**WEIGHT** 2,8 kg

**SPARE PARTS**  
 8000 CUBE Headset Orbit Z 1.5E ZS  
 8651 CUBE HANGER\_mtb-x12-std-2020 (18-05516)

HARDTAIL

# REACTION HYBRID SL 29

grey 'n' orange



# REACTION HYBRID SL 29

blue 'n' yellow



Trapeze | grey 'n' orange



Trapeze | blue 'n' yellow



The SL tag isn't one that we dish out lightly. In the case of our brand-new Reaction Hybrid SL, the combination of the completely redesigned aluminium frame and a selection of light, smooth and desirable components means that it's thoroughly earned. More than just an object of beauty, it's a design marvel in its own right – and more desirable than ever, thanks to the fourth-generation Bosch CX drive unit. Our engineering team started from scratch with this bike, developing an all-new Modular Battery System which houses the power unit inside a custom-designed, gravity cast down tube, out of the way of dust, dirt and water. It also enables the use of an even higher capacity battery, meaning that you can ride further and for longer than ever before. Details like the 1.5in head tube, oversized chain stays and Boost rear axle ensure that every watt of the Bosch drive unit's power is efficiently transferred to the rear wheel, while revised Agile Ride Geometry designed around the 120mm RockShox Recon air fork serves up the ideal blend of agility when you want it, and stability when you need it. There's even provision for an easy stealth dropper post upgrade, should your riding ambitions demand it. Powerful Magura hydraulic disc brakes – with a 203mm rotor at the front for even more power under prolonged, heavy braking – and extra-wide, grippy Schwalbe tyres ensure you're always in complete control. And, of course, the smooth and seamless Bosch CX drive unit and Kiox controller deliver pedal-enhancing torque to the rear wheel via Sram's NX Eagle 12-speed transmission. It all means you've got the range, power and control to ride wherever your curiosity takes you – and keep coming back for more. Ride further, ride faster and ride more often. Why not?

- ★ **334362** Cube Reaction Hybrid SL 625 29 blue 'n' yellow 2020
- ★ **334352** Cube Reaction Hybrid SL 625 29 grey 'n' orange 2020

**FRAME** Aluminium Superlite, Gravity Casting, Agile Ride Geometry, 1.5 Headtube, Boost 148, Internal Cable Routing, Full Integrated Battery, Kickstand/Fender/Carrier Mounting Points  
**SIZE** #5", 17", 19", 21", 23", Trapeze: 15", 17", 19"  
**FORK** #RockShox Recon RL Air, Tapered, 15x110mm, eMTB Approved, 120mm

**DRIVE UNIT** #Bosch Drive Unit Performance CX Generation 4 (75Nm) Cruise (250Watt)  
**BATTERY** #Bosch PowerTube 625  
**DISPLAY** #Bosch Kiox  
**CHARGER** #Bosch 2A

**HEADSET** #SA Orbit Z 1.5E ZS, Top Zero-Stack 1 1/2" (OD 56mm), Bottom Zero-Stack 1 1/2" (OD 56mm)  
**STEM** #CUBE Performance Stem, 31.8mm  
**HANDLEBAR** #Newmen Evolution 318.10, 720mm  
**GRIPS** #CUBE Race Grip 31mm, 1-Clamp  
**REAR DERAILLEUR** #Sram NX Eagle™, 12-Speed  
**SHIFTERS** #Sram NX Eagle™ Trigger, Single Click  
**BRAKE SYSTEM** #Magura MT Fifty, Hydr. Disc Brake (203/180)  
**CRANKSET** #CID E-Crank, 38T, 175mm  
**CASSETTE** #Sram PG-1210 Eagle™, 11-50T  
**CHAIN** #Sram SX Eagle™  
**RIMS** #CUBE EX30, 32H, Disc, Tubeless Ready  
**FRONT HUB** #Shimano HB-MT400-B, 15mm, Boost, Centerlock  
**REAR HUB** #Shimano FH-MT400-B, 12mm, Boost, Centerlock  
**TYRES** #Schwalbe Smart Sam, Active, 2.60  
**PEDALS** #CUBE PP MTB  
**SADDLE** #Natural Fit Sequence+  
**SEAT POST** #CUBE Performance Post, 30.9mm  
**SEATCLAMP** #CUBE Varioclose, 34.9mm

**WEIGHT** #3,3 kg

**SPARE PARTS**  
**8000** CUBE Headset Orbit Z 1.5E ZS  
**8651** CUBE HANGER\_mtb-x12-std-2020 (18-05516)



16169

CUBE HELMET ROOK



11028

CUBE AM ZIP OFF PANT



11438

SQUARE JERSEY SPORT

# REACTION HYBRID EXC 29

iridium 'n' green



# REACTION HYBRID EXC 29

petrol 'n' red



Trapeze | iridium 'n' green



Trapeze | petrol 'n' red



Evolution has brought us to this point: a 29er hybrid mountain bike, powered by Bosch's fourth-generation drive system and Shimano's 12-speed XT and SLX components. The Reaction Hybrid EXC 29 is the latest iteration of our constant quest to build smooth, fast, comfortable and affordable off-roaders. Designed around our brand-new Modular Battery System, it houses the Bosch power unit entirely within the stiff, strong down tube for a sleek appearance and unparalleled usability. Not only is it possible to charge the battery without removing it from the frame, but the new design has enabled the option of an even higher capacity unit for extended range. Revised geometry works with the Suntour XCR34 Boost fork and extra-wide Schwalbe 2.6in tyres to deliver safe, predictable handling that's lively when you want it, and confidence inspiring when you need it. The uncannily smooth and seamless power delivery of Bosch's fourth-generation CX drive unit is transferred to the rear wheel via Shimano's SLX and XT 12-speed drivetrain. Known for its matchless reliability and smooth shifting, the new Shimano 12-speed system also offers an unmatched gear range to make even the most daunting of climbs easier to ride. And, of course, we included powerful Shimano four-piston hydraulic disc brakes at the front, to ensure that you're always in full control. With a trapeze frame option and a wide range of sizes, there's a Reaction Hybrid EXC 29 to suit every rider. It's your gateway to more riding possibilities...

- ★ **334322** Cube Reaction Hybrid EXC 625 29 petrol 'n' red 2020
- 334321** Cube Reaction Hybrid EXC 500 29 petrol 'n' red 2020
- 334312** Cube Reaction Hybrid EXC 625 29 iridium 'n' green 2020
- 334311** Cube Reaction Hybrid EXC 500 29 iridium 'n' green 2020

**FRAME** Aluminium Superlite, Gravity Casting, Agile Ride Geometry, 1.5 Headtube, Boost 148, Internal Cable Routing, Full Integrated Battery, Kickstand/Fender/Carrier Mounting Points  
**SIZE** #5", 17", 19", 21", 23", Trapeze: 15", 17", 19"  
**FORK** Suntour XCR34 LO-R Air, Tapered, 15x110mm, 120mm, Lockout

**DRIVE UNIT** Bosch Drive Unit Performance CX Generation 4 (75Nm) Cruise (250Watt)  
**BATTERY** Bosch PowerTube 625  
**DISPLAY** Bosch Purion  
**CHARGER** Bosch 2A

**HEADSET** SA Orbit Z 1.5B ZS, Top Zero-Stack 1 1/2" (OD 56mm), Bottom Zero-Stack 1 1/2" (OD 56mm)  
**STEM** CUBE Performance Stem, 31.8mm  
**HANDLEBAR** CUBE Rise Trail Bar, 700mm  
**GRIPS** CUBE Race Grip 31mm, 1-Clamp  
**REAR DERAILLEUR** Shimano XT RD-M8100-SGS, ShadowPlus, 12-Speed  
**SHIFTERS** Shimano SLX SL-M7100  
**BRAKE SYSTEM** Shimano BR-MT420/MT400, Hydr. Disc Brake (203/180)  
**CRANKSET** CID E-Crank, 38T, 175mm  
**CASSETTE** Shimano SLX CS-M7100, 10-51T  
**CHAIN** Shimano SLX CN-M7100  
**RIMS** CUBE EX30, 32H, Disc, Tubeless Ready  
**FRONT HUB** Shimano HB-MT400-B, 15mm, Boost, Centerlock  
**REAR HUB** Shimano FH-MT510-B, 12mm, Boost, Centerlock  
**TYRES** Schwalbe Smart Sam, Active, 2.60  
**PEDALS** CUBE PP MTB  
**SADDLE** Natural Fit Sequence  
**SEAT POST** CUBE Performance Post, 30.9mm  
**SEATCLAMP** CUBE Varioclose, 34.9mm

**WEIGHT** #3,1 kg

**SPARE PARTS**  
**8000** CUBE Headset Orbit Z 1.5E ZS  
**8651** CUBE HANGER\_mtb-x12-std-2020 (18-05516)



11059

SQUARE JERSEY ACTIVE



11408

SQUARE BAGGY SHORTS ACTIVE



17085

CUBE SHOES ATX LYNX PRO



# REACTION HYBRID EX 29

black'n'blue



# REACTION HYBRID EX 29

green'n'orange



Trapeze | black'n'blue



Trapeze | green'n'orange



One of the defining characteristics of our designers is that they never rest on their laurels. With the brand-new, fourth-generation Bosch CX-powered Reaction Hybrid EX, they've pulled out all the stops to build a Bosch e-MTB that will help redefine what's possible from a hybrid hardtail. The frame is a masterpiece of elegantly functional engineering, combining sleek good looks with incredible handling, unmatched practicality and the superb strength and durability that you'd expect as a result of our extensive in-house testing – and it's available in a trapeze frame option, too. A brand-new Modular Battery System encloses the Bosch power unit inside the gravity cast down tube and allows for even more range, whilst oversized chain stays, a Boost rear axle and a 1.5in head tube ensure that the power delivery is as efficient as it is smooth. A dropper post-ready seat tube, revised geometry and elegant Smooth Welding complete the picture. To make the most of this amazing new frame, we selected components that offer great value and performance. Up front, the Suntour XCM34-Boost fork delivers accurate steering and 120mm of trail-smoothing travel, whilst 2.6in Schwalbe tyres serve up unbelievable grip and comfort. Sram's peerless SX Eagle 12-speed transmission works seamlessly with the Bosch CX drive unit to help power you further, faster and higher than you'd think possible, and powerful Shimano hydraulic disc brakes put you in full control, no matter what the trail or weather dishes out. You'll be amazed what this bike can do for your riding. We were – and we were the ones who designed it.

- ★ **334262** Cube Reaction Hybrid EX 625 29 green'n'orange 2020
- 334261** Cube Reaction Hybrid EX 500 29 green'n'orange 2020
- 334252** Cube Reaction Hybrid EX 625 29 black'n'blue 2020
- 334251** Cube Reaction Hybrid EX 500 29 black'n'blue 2020

**FRAME** Aluminium Superlite, Gravity Casting, Agile Ride Geometry, 1.5 Headtube, Boost 148, Internal Cable Routing, Full Integrated Battery, Kickstand/Fender/Carrier Mounting Points  
**SIZE** #5", 17", 19", 21", 23", Trapeze: 15", 17", 19"  
**FORK** SR Suntour XCM34 Coil, Tapered, 15x110mm, 120mm, Lockout

**DRIVE UNIT** Bosch Drive Unit Performance CX Generation 4 (75Nm) Cruise (250Watt)  
**BATTERY** Bosch PowerTube 625  
**DISPLAY** Bosch Purion  
**CHARGER** Bosch 2A

**HEADSET** SA Orbit Z 1.5B ZS, Top Zero-Stack 1 1/2" (OD 56mm), Bottom Zero-Stack 1 1/2" (OD 56mm)  
**STEM** CUBE Performance Stem, 31.8mm  
**HANDLEBAR** CUBE Rise Trail Bar, 700mm  
**GRIPS** CUBE Race Grip 31mm, 1-Clamp  
**REAR DERAILLEUR** Sram SX Eagle™, 12-Speed  
**SHIFTERS** Sram SX Eagle™ Trigger, Single Click  
**BRAKE SYSTEM** Shimano BR-MT420/MT400, Hydr. Disc Brake (203/180)  
**CRANKSET** CID E-Crank, 38T, 175mm  
**CASSETTE** Sram PG-1210 Eagle™, 11-50T  
**CHAIN** Sram SX Eagle™  
**RIMS** CUBE EX30, 32H, Disc, Tubeless Ready  
**FRONT HUB** Shimano HB-MT400-B, 15mm, Boost, Centerlock  
**REAR HUB** Shimano FH-MT400-B, 12mm, Boost, Centerlock  
**TYRES** Schwalbe Smart Sam, Active, 2.60  
**PEDALS** CUBE PP MTB  
**SADDLE** Natural Fit Sequence  
**SEAT POST** CUBE Performance Post, 30.9mm  
**SEATCLAMP** CUBE Varioclose, 34.9mm

**WEIGHT** #4,1 kg

**SPARE PARTS#**  
**8000** CUBE Headset Orbit Z 1.5E ZS  
**8651** CUBE HANGER\_mtb-x12-std-2020 (18-05516)



16174

CUBE HELMET PATHOS



93046

ACID MUDGUARD SET MTB 75 WITH STAYS



11960

CUBE GLOVES X NF

# REACTION HYBRID EX ALLROAD 29

Trapeze | black'n'blue



# REACTION HYBRID EX ALLROAD 29

black'n'blue

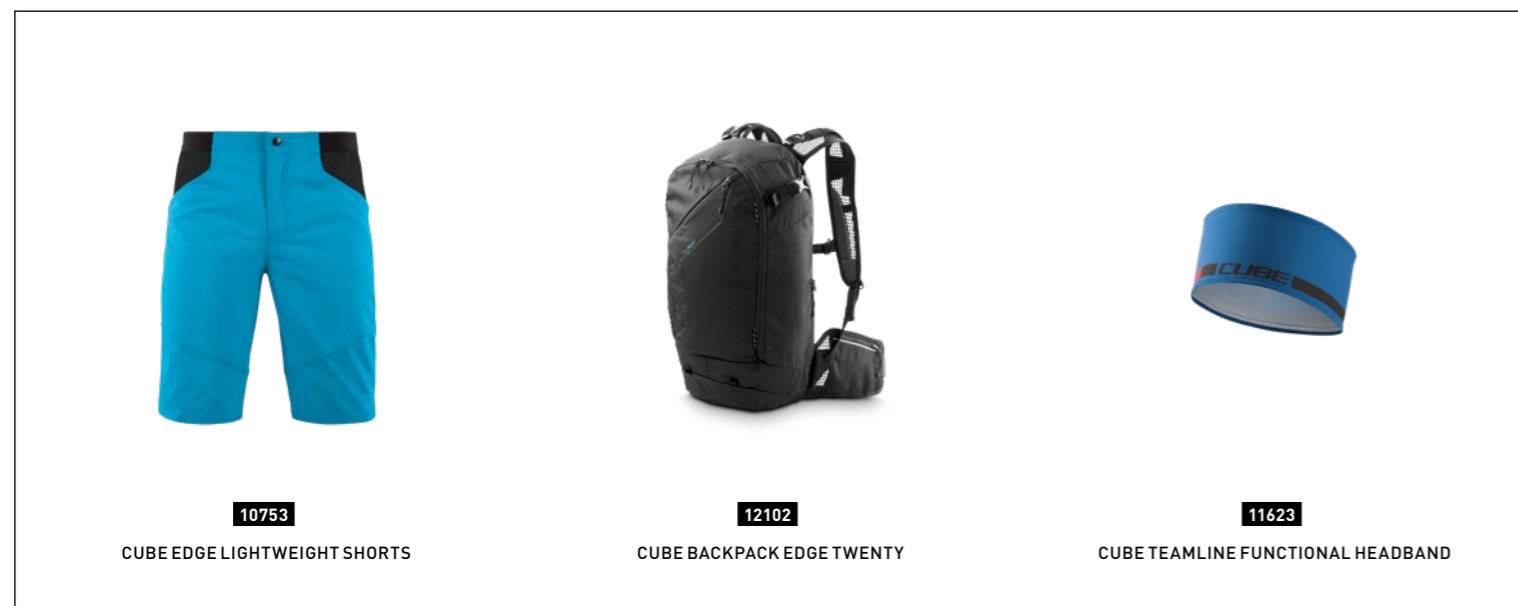

Sometimes you need a bike to do it all – one machine to tackle everything from the mean streets of the city to the buff trails in the forest. The new Reaction Hybrid EX Allroad is that bike. With a sleek new frame incorporating a raft of new design features, Bosch's fourth-generation CX drive unit and a selection of components and accessories hand-picked to offer the best in value and performance, it's everything you need to take life's adventures in your stride. The beautifully thought out CUBE Modular Battery System houses the Bosch power unit safely inside the stiff, strong, gravity cast down tube, allowing the option of a bigger capacity battery than ever before for even more range. Revised geometry is designed around the Suntour XCM34-Boost 120mm fork, offering the ideal blend of stability and agility for fun, safe riding wherever you go – and there's the option of a trapeze frame version, too. Features like the Boost rear axle, oversized chain stays and 1.5in head tube are all designed to ensure the best possible handling and power transfer, and we've even made the seat tube stealth dropper post-ready, in case your riding ambitions demand a future upgrade. The neatly integrated kickstand and mudguard mounting points mean that these essential accessories complement the frame's svelte looks perfectly. And the powerful, smooth Bosch CX drive unit delivers its pedal-boosting torque to the rear wheel via Sram's superb SX Eagle 12-speed transmission – so you can ride further, faster and for longer than ever before. We even included front and rear lights so you can see and be seen, powered by the Bosch battery for ease of use and peace of mind. Grippy, big-volume Schwalbe tyres serve up all the traction and comfort you need, working in tandem with powerful Shimano hydraulic disc brakes to ensure you're always in control of your speed, whatever the weather or trail conditions. There really is nothing stopping you from riding wherever you want, however you want. Where will you go next?

- ★ **334302** Cube Reaction Hybrid EX 625 Allroad 29 black'n'blue 2020
- ★ **334301** Cube Reaction Hybrid EX 500 Allroad 29 black'n'blue 2020

**FRAME** Aluminium Superlite, Gravity Casting, Agile Ride Geometry, 1.5 Headtube, Boost 148, Internal Cable Routing, Full Integrated Battery, Kickstand/Fender/Carrier Mounting Points  
**SIZE** #5", 17", 19", 21", 23", Trapeze: 15", 17", 19"  
**FORK** #Suntour XCM34 Coil, Tapered, 15x110mm, 120mm, Lockout

**DRIVE UNIT** #Bosch Drive Unit Performance CX Generation 4 (75Nm) Cruise (250Watt)  
**BATTERY** #Bosch PowerTube 625  
**DISPLAY** #Bosch Purion  
**CHARGER** #Bosch 2A

**HEADSET** #SA Orbit Z 1.5B ZS, Top Zero-Stack 1 1/2" [OD 56mm], Bottom Zero-Stack 1 1/2" [OD 56mm]  
**STEM** #CUBE Performance Stem, 31.8mm  
**HANDLEBAR** #CUBE Rise Trail Bar, 700mm  
**GRIPS** #CUBE Race Grip 31mm, 1-Clamp  
**REAR DERAILLEUR** #Sram SX Eagle™, 12-Speed  
**SHIFTERS** #Sram SX Eagle™ Trigger, Single Click  
**BRAKE SYSTEM** #Shimano BR-MT420/MT400, Hydr. Disc Brake (203/180)  
**CRANKSET** #CID E-Crank, 38T, 175mm  
**CASSETTE** #Sram PG-1210 Eagle™, 11-50T  
**CHAIN** #Sram SX Eagle™  
**RIMS** #CUBE EX30, 32H, Disc, Tubeless Ready  
**FRONT HUB** #Shimano HB-MT400-B, 15mm, Boost, Centerlock  
**REAR HUB** #Shimano FH-MT400-B, 12mm, Boost, Centerlock  
**TYRES** #Schwalbe Smart Sam, Active, 2.60  
**PEDALS** #CUBE PP MTB  
**SADDLE** #Natural Fit Sequence  
**SEAT POST** #CUBE Performance Post, 30.9mm  
**SEATCLAMP** #CUBE Varioclose, 34.9mm  
**FRONT LIGHT** #AXA Compactline 20, 6-12V, DC  
**REAR LIGHT** #Busch&Müller Xeltec, DC  
**KICKSTAND** #CUBEstand Cmp  
**MUDGUARDS** #CID 75  
**BELL** #Mini Bell

**SPARE PARTS**  
**8000** CUBE Headset Orbit Z 1.5E ZS  
**8651** CUBE HANGER\_mtb-x12-std-2020 [18-05516]

**WEIGHT** #5,2 kg

HARDTAIL

---

## FOR us #Mountainbikers

---

We've years of experience building Bosch-powered mountain bike hybrids – and we put all of that knowledge to good use in the brand-new Reaction Hybrid frame. Designed around the needs of Bosch's superb fourth-generation drive system, we built a frame that's sleeker, better handling and easier to live with than ever – and, with our Size Split system and a trapeze frame option on some models, we've the perfect size and fit for every rider. Housing the Bosch battery securely in its gravity cast down tube, our engineers also routed all cables internally to keep them out of harm's way and keep gear shifts clean and precise with minimal maintenance. The 1.5in head tube and Agile Ride Geometry delivers impeccably precise steering, there's an integrated kickstand mount and we even ensured that there's routing for a stealth dropper post upgrade, so your Reaction Hybrid will stay with you as your riding skills develop. It's everything that you need, and nothing that you don't.



# REACTION HYBRID RACE

black'n' red



# REACTION HYBRID RACE

blue'n'green

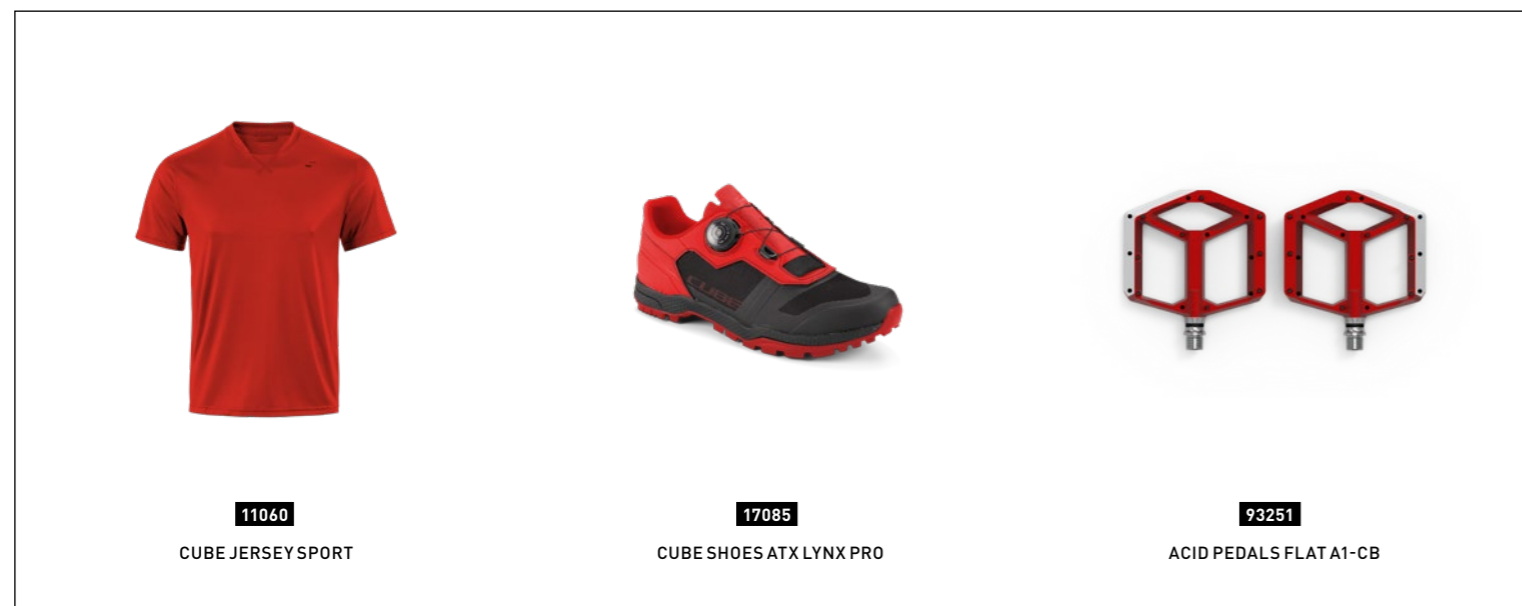

11060

CUBE JERSEY SPORT



17085

CUBE SHOES ATX LYNX PRO



93251

ACID PEDALS FLAT A1-CB

If you want to get more fun out of your riding, you could do a lot worse than invest in a CUBE Bosch e-MTB. And, if you're going to do that, there are very few bikes around that can match the Reaction Hybrid Race for value and performance. Blending all our engineers' accumulated experience in a beautifully crafted, completely revised frame designed around the requirements of Bosch's fourth-generation CX drive unit, it represents a new standard in great value, high performance off-road e-biking. Keen riders will spot the attention to detail in areas like the 1.5in head tube – for superb steering accuracy – and a 30.9mm seat tube that's remote dropper post ready, in case you want to take your riding to an adventurous new level. The neatly integrated Bosch CX drive unit and battery deliver a seamless, quiet and smooth power boost for mile after mile, working in tandem with Shimano's new XT 12-speed transmission and its incredibly wide-ranging 10-51T cassette. Make light work of every climb, explore further afield or just fit more into your riding time – it's all there for the taking. A RockShox Judy Silver air fork serves up 100mm of easily adjustable, rock-swallowing travel and extra-wide, grippy Schwalbe Smart Sam tyres roll smoothly and easily down the trail. Power is, of course, nothing without control – and that's why we fitted powerful Shimano four-piston hydraulic disc brakes. And the Reaction Hybrid Race is available with our Size Split setup, so every rider can find their perfect fit. Whatever your riding ambitions, this is the bike to put the fun back into every pedal stroke. What are you waiting for?

- ★ **334211** Cube Reaction Hybrid Race 500 blue'n'green 2020
- ★ **334201** Cube Reaction Hybrid Race 500 black'n'red 2020

**FRAME** Aluminium Superlite, Gravity Casting, Agile Ride Geometry, 1.5 Headtube, Internal Cable Routing, Semi-Integrated Battery, Kickstand/Fender/Carrier Mounting Points  
**SIZE** Size Split: 27.5: 13.5", 15" // 29: 17", 19", 21", 23"  
**FORK** RockShox Judy Silver TK Air, Tapered, 15x110mm, 100mm, eMTB Approved, Lockout

**DRIVE UNIT** Bosch Drive Unit Performance CX Generation 4 (75Nm) Cruise (250Watt)  
**BATTERY** Bosch PowerPack 500  
**DISPLAY** Bosch Purion  
**CHARGER** Bosch 2A

**HEADSET** SA Orbit Z 1.5B ZS, Top Zero-Stack 1 1/2" (OD 56mm), Bottom Zero-Stack 1 1/2" (OD 56mm)  
**STEM** CUBE Performance Stem, 31.8mm  
**HANDLEBAR** CUBE Rise Trail Bar Pro, 720mm  
**GRIPS** CUBE Race Grip 31mm, 1-Clamp  
**REAR DERAILLEUR** Shimano XT RD-M8100-SGS, ShadowPlus, 12-Speed  
**SHIFTERS** Shimano SLX SL-M7100  
**BRAKE SYSTEM** Shimano BR-MT420, Hydr. Disc Brake (180/180)  
**CRANKSET** CID E-Crank, 38T, 175mm  
**CASSETTE** Shimano SLX CS-M7100, 10-51T  
**CHAIN** Shimano SLX CN-M7100  
**RIMS** CUBE EX30, 32H, Disc, Tubeless Ready  
**FRONT HUB** Shimano HB-MT400-B, 15mm, Boost, Centerlock  
**REAR HUB** Shimano FH-MT500, QR, Centerlock  
**TYRES** Schwalbe Smart Sam, Active, 2.60  
**PEDALS** CUBE PP MTB  
**SADDLE** Natural Fit Sequence  
**SEAT POST** CUBE Performance Post, 30.9mm  
**SEATCLAMP** CUBE Varioclose, 34.9mm

**WEIGHT** 1,9 kg

**SPARE PARTS**  
**8000** CUBE Headset Orbit Z 1.5E ZS  
**10148** CUBE Hanger #148 short version



# REACTION HYBRID PRO

iridium 'n' black



# REACTION HYBRID PRO

pinetree 'n' orange



Trapeze | iridium 'n' black



Trapeze | pinetree 'n' orange



Our designers always start with a clear goal in mind. In the case of the Reaction Hybrid Pro, it was a simple one: build a Bosch e-bike that will help its rider get more out of the trails they ride. To that end, they went back to the drawing board for 2020 and came up with a brand-new frame design that's sleeker, stiffer and more versatile than ever, incorporating Bosch's fourth-generation CX motor. Integrated cable routing complements the clean lines and reduces maintenance, whilst compatibility with CUBE accessories and a remote dropper post makes upgrading and accessorising a cinch. The seamlessly integrated Bosch drive unit and battery, controlled via a Purion handlebar-mounted interface, quietly and efficiently gets on with the job of boosting your pedal power for easier climbs, faster routes and expanded horizons. You can even charge the battery without removing it from the frame. Sram's superb SX Eagle 12-speed transmission provides an awesome gear range, while Shimano's smooth, powerful MT200 hydraulic disc brakes ensure you can control your speed whatever the weather or trail conditions. Extra-wide, grippy Schwalbe Smart Sam tyres offer ample grip and cushioning and our Natural Fit Sequence saddle ensures you'll stay comfortable on even the longest rides. Best of all, our Size Split system – and the option of a trapeze frame – means that there's a Reaction Hybrid Pro to suit every rider. Which means that there's nothing stopping you from getting more out of your riding...

- ★ **334111** Cube Reaction Hybrid Pro 500 pinetree 'n' orange 2020
- ★ **334101** Cube Reaction Hybrid Pro 500 iridium 'n' black 2020

**FRAME** Aluminium Superlite, Gravity Casting, Agile Ride Geometry, 1.5 Headtube, Internal Cable Routing, Semi-Integrated Battery, Kickstand/Fender/Carrier Mounting Points  
**SIZE** Size Split: 27.5: 13.5", 15" // 29: 17", 19", 21", 23"; Trapeze 27.5: 15" // 29: 17", 19"  
**FORK** Suntour XCM34 Coil, Tapered, 15x110mm, 100mm, Lockout

**DRIVE UNIT** Bosch Drive Unit Performance CX Generation 4 (75Nm) Cruise (250Watt)  
**BATTERY** Bosch PowerPack 500  
**DISPLAY** Bosch Purion  
**CHARGER** Bosch 2A

**HEADSET** SA Orbit Z 1.5B ZS, Top Zero-Stack 1 1/2" (OD 56mm), Bottom Zero-Stack 1 1/2" (OD 56mm)  
**STEM** CUBE Performance Stem, 31.8mm  
**HANDLEBAR** CUBE Rise Trail Bar, 700mm  
**GRIPS** CUBE Performance Grip  
**REAR DERAILLEUR** Sram SX Eagle™, 12-Speed  
**SHIFTERS** Sram SX Eagle™ Trigger, Single Click  
**BRAKE SYSTEM** Shimano BR-MT200, Hydr. Disc Brake (180/180)  
**CRANKSET** CID E-Crank, 38T, 175mm  
**CASSETTE** Sram PG-1210 Eagle™, 11-50T  
**CHAIN** Sram SX Eagle™  
**RIMS** CUBE EX30, 32H, Disc, Tubeless Ready  
**FRONT HUB** Shimano HB-MT400-B, 15mm, Boost, Centerlock  
**REAR HUB** Shimano FH-TX505, QR, Centerlock  
**TYRES** Schwalbe Smart Sam, Active, 2.60  
**PEDALS** CUBE PP MTB  
**SADDLE** Natural Fit Sequence  
**SEAT POST** CUBE Performance Post, 30.9mm  
**SEATCLAMP** CUBE Varioclose, 34.9mm

**WEIGHT** #2,9 kg

**SPARE PARTS#**  
**8000** CUBE Headset Orbit Z 1.5E ZS  
**10148** CUBE Hanger #148 short version



11282

CUBE TOUR BAGGY SHORTS



16240

CUBE HELM BADGER



11289

CUBE TOUR TRIKOT



# REACTION HYBRID PRO ALLROAD

Trapeze | iridium'n'black



# REACTION HYBRID PRO ALLROAD

iridium'n'black

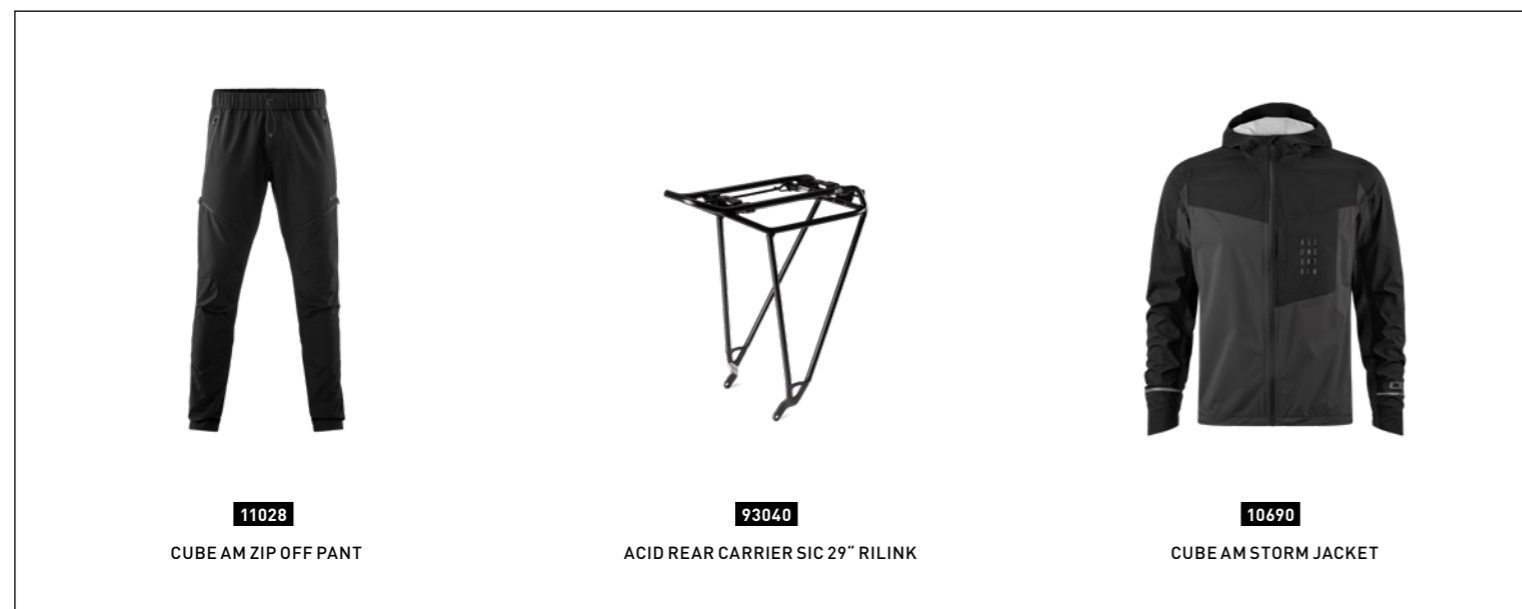
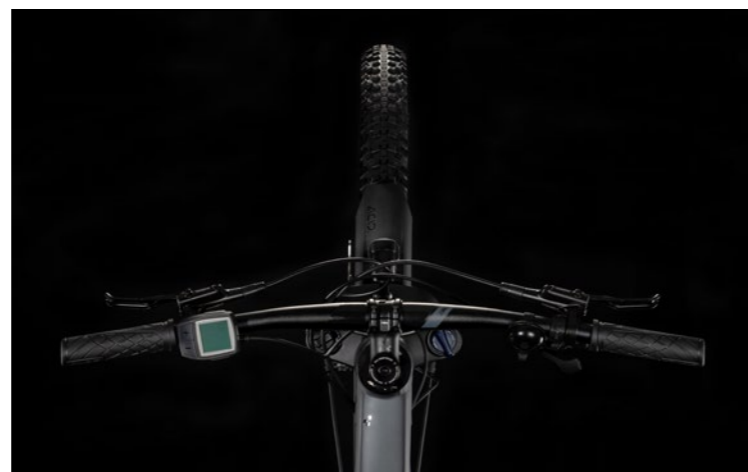

11028  
CUBE AM ZIP OFF PANT

93040  
ACID REAR CARRIER SIC 29" RILINK

10690  
CUBE AM STORM JACKET

We reckon the Swiss were onto something when they invented the do-it-all pocket knife. On the other hand, we also think we can go one better: the do-it-all Bosch e-bike. The Reaction Hybrid Pro Allroad combines all the rugged appeal of a go-anywhere mountain bike hardtail with the practical versatility of a tourer, all served up with the boost of Bosch's smooth, powerful fourth-generation CX drive unit. Boasting a completely revised frame for 2020, dedicated attachment points for the included kickstand, mudguards and lights mean that the Reaction Hybrid Pro Allroad's svelte looks aren't spoiled by the addition of these essential accessories. The sleekly integrated Bosch CX drive unit and battery seamlessly dish out mile after mile of rider-boosting torque and power via the slick-shifting, wide-ranging Sram SX Eagle 12-speed transmission, putting every hill within easy reach and promising longer, faster and more adventurous rides – and there's no need to remove the battery for charging. A Suntour suspension fork offers 100mm of bump-absorbing travel, smoothing out the ride with the help of Schwalbe's extra-wide, grippy and comfortable Smart Sam tyres. And, thanks to strong and easily controllable Shimano hydraulic disc brakes, you'll always be in full control of your speed, whatever weather you find yourself riding in. The added bonus is that, because of our Size Split system and the option of a trapeze frame, every rider will be able to find their perfect fit. From urban commuter to weekend adventure seeker, the Reaction Hybrid Pro Allroad has got you covered. Just don't forget to pack your pocket knife too...

★ 334151 Cube Reaction Hybrid Pro 500 Allroad iridium'n'black 2020

**FRAME** Aluminium Superlite, Gravity Casting, Agile Ride Geometry, 1.5 Headtube, Internal Cable Routing, Semi-Integrated Battery, Kickstand/Fender/Carrier Mounting Points  
**SIZE** Size Split: 27.5: 13.5", 15" // 29: 17", 19", 21", 23"; Trapeze 27.5: 15" // 29: 17", 19"  
**FORK** Suntour XCM34 Coil, Tapered, 15x110mm, 100mm, Lockout

**DRIVE UNIT** Bosch Drive Unit Performance CX Generation 4 (75Nm) Cruise (250Watt)  
**BATTERY** Bosch PowerPack 500  
**DISPLAY** Bosch Purion  
**CHARGER** Bosch 2A

**HEADSET** SA Orbit Z 1.5B ZS, Top Zero-Stack 1 1/2" (OD 56mm), Bottom Zero-Stack 1 1/2" (OD 56mm)  
**STEM** CUBE Performance Stem, 31.8mm  
**HANDLEBAR** CUBE Rise Trail Bar, 700mm  
**GRIPS** CUBE Performance Grip  
**REAR DERAILLEUR** Sram SX Eagle™, 12-Speed  
**SHIFTERS** Sram SX Eagle™ Trigger, Single Click  
**BRAKE SYSTEMS** Shimano BR-MT200, Hydr. Disc Brake (180/180)  
**CRANKSET** CID E-Crank, 38T, 175mm  
**CASSETTE** Sram PG-1210 Eagle™, 11-50T  
**CHAIN** Sram SX Eagle™  
**RIMS** CUBE EX30, 32H, Disc, Tubeless Ready  
**FRONT HUB** Shimano HB-MT400-B, 15mm, Boost, Centerlock  
**REAR HUB** Shimano FH-TX505, QR, Centerlock  
**TYRES** Schwalbe Smart Sam, Active, 2.60  
**PEDALS** CUBE PP MTB  
**SADDLE** Natural Fit Sequence  
**SEAT POST** CUBE Performance Post, 30.9mm  
**SEATCLAMP** CUBE Varioclose, 34.9mm  
**FRONT LIGHT** AXA Compactline 20, 6-12V, DC  
**REAR LIGHT** Busch&Müller Xeltec, DC  
**KICKSTAND** CUBEstand CmpT  
**MUDGUARDS** CID 75  
**BELL** Mini Bell

**SPARE PARTS**  
**8000** CUBE Headset Orbit Z 1.5E ZS  
**10148** CUBE Hanger #148 short version

**WEIGHT** #4,3 kg

HARDTAIL

# REACTION HYBRID ONE

black'n'blue



# REACTION HYBRID ONE

red'n'orange



Not available in all markets.



16174

CUBE HELMET PATHOS



93264

ACID PEDALS FLAT C1-1B



92989

ACID MUDGUARD VANE DISC REAR 29"

HARDTAIL



---

## FOR us #Discoverers

---

Why shouldn't a hybrid 29er mountain bike have an Easy Entry frame? That was the question we asked ourselves when we first came up with the idea for the Nuride Hybrid. And, other than the fact that building a step-through frame that's strong enough to also withstand off-road use is an engineering challenge in its own right, we couldn't come up with a good answer. Luckily, we like challenges. So we built it. And here's the result – an elegant, capable hybrid that will happily go wherever your curiosity takes you, powered by Bosch's superb fourth-generation drive unit. Built around our Modular Battery System, the heart of this clever bike is the gravity cast down tube, which houses the Bosch power unit under an easily accessed cover. It's so neat that many people won't recognise it as a hybrid, but it also allows us to offer the option of a bigger capacity battery for extended range. With 100mm of comfort-enhancing suspension fork travel and geometry that's designed to make it stable and comfortable to ride, it's the ideal way to expand your riding horizons.



# NURIDE HYBRID SL ALLROAD

blue'n'blue



For those times in life when only the best will do, may we suggest that the Nuride SL Allroad is the fourth-generation Bosch e-bike for the job? With the flexibility of a beautifully crafted Easy Entry frame, the versatility of a 29er mountain bike's go-anywhere ability, the power of Bosch's superb new CX drive unit and a selection of the very best components, it's exactly the right bike to enable you to rediscover the joy of pedalling. Key to its usability is the brand-new Easy Entry frame, designed around our unique Modular Battery System. With the Bosch power unit completely concealed inside the stiff, strong main frame tube, our engineers were able to make room for a higher capacity battery for extended range, as well as ensuring that the Nuride Hybrid SL Allroad is incredibly easy to step in and out of. Bosch's sleek fourth-generation CX drive unit seamlessly and effortlessly boosts your pedalling, transferring power to the rear wheel via Shimano's legendary XT 1x12 transmission. Featuring incredibly smooth shifting, impressive durability and the widest possible gear range, you'll be amazed at the ease with which this combination opens up new route choices. Matching four-piston Shimano XT hydraulic disc brakes offer reassuring stopping ability come rain or shine, and Fox's smooth and easily adjustable 34 Rhythm suspension fork – combined with wide Schwalbe 2.35in 29er tyres – creates a ride so smooth it's almost magic carpet-like. We even added a kickstand, mudguards and a full lighting set, so you're fully equipped for whatever adventure takes your fancy. Now, where will you ride next?

★ **332902** Cube Nuride Hybrid SL 625 Allroad blue'n'blue 2020

**FRAME** Aluminum Superlite, Agile Comfort Geometry, Full Integrated Battery, Kickstand/ Fender/Carrier Mounting Points  
**SIZE** Easy Entry: 46, 50, 54, 58  
**FORK** Fox 34 Rhythm, 2-Position Sweep-Adjust GRIP Damper, Tapered, 15x110mm, E-Bike Optimized, 100mm

**DRIVE UNIT** Bosch Drive Unit Performance CX Generation 4 (75Nm) Cruise (250Watt)  
**BATTERY** Bosch PowerTube 625  
**DISPLAY** Bosch Kiox  
**CHARGER** Bosch 4A

**HEADSET** SA Orbit 1.5B ZS, Head Block System, Top Zero-Stack 1 1/8" (OD 44mm), Bottom Zero-Stack 1 1/2" (OD 56mm)  
**STEM** Satori Up2 Plus, 31.8mm, Adjustable  
**HANDLEBAR** CUBE Comfort Trail Bar, 720mm  
**GRIPS** Natural Fit All Terrain  
**REAR DERAILLEUR** Shimano XT RD-M8100-SGS, ShadowPlus, 12-Speed  
**SHIFTERS** Shimano XT SL-M8100-I Direct Attach  
**BRAKE SYSTEM** Shimano XT BR-M8120, Hydr. Disc Brake (180/180)  
**CRANKSET** Acid E-Crank, 38T, 175mm  
**CASSETTE** Shimano SLX CS-M7100, 10-51T  
**CHAIN** Shimano SLX CN-M7100  
**RIMS** CUBE EX30, 32H, Disc, Tubeless Ready  
**FRONT HUB** Shimano HB-MT400-B, 15QR, Boost, Centerlock  
**REAR HUB** Shimano FH-MT500, QR, Centerlock  
**TYRES** Schwalbe Smart Sam, K-Guard, 2.35  
**PEDALS** CUBE PP MTB  
**SADDLE** Natural Fit Sequence+ Comfort  
**SEAT POST** R Sountour NCX Suspension Seatpost, 30.9mm  
**SEATCLAMP** CUBE Varioclose, 34.9mm  
**FRONT LIGHT** Hermanns H-Black MR8, 6-12V, DC  
**REAR LIGHT** Busch&Müller Xeltec, DC  
**KICKSTAND** CUBEstand Cmp  
**MUDGUARDS** ACID 65  
**BELL** Mini Bell

**SPARE PARTS**  
**8002** CUBE Headset ORBIT 1.5E ZS + crown race 1 1/8"  
**10148** CUBE Hanger #148 short version

**WEIGHT** #5,6 kg



**10722**  
CUBE SHOES ATX LOXIA



**11960**  
CUBE GLOVES XNF



**93270**  
ACID PEDALS FLAT C1-IB HYBRID

# NURIDE HYBRID EXC

grey 'n' black



# NURIDE HYBRID EXC

green 'n' sharpgreen



When we set out to design the new Nuride Hybrid EXC we asked ourselves a simple question: why shouldn't a versatile, well-equipped Bosch e-MTB also have an Easy Entry frame? It's not easy to build such a frame that's stiff and strong enough for the job, but our engineers love a challenge – and our in-house test lab makes sure that they've got their sums right, and that the results of their endeavours are every bit as safe and durable as they should be. Incorporating our new Modular Battery System, the space inside the down tube is big enough to offer the option of a higher capacity battery for even greater range, while the gravity casting and careful profiling ensure it's a stiff, strong backbone for the whole bike. Sram's incredible SX Eagle 12-speed transmission works with the new, fourth-generation Bosch CX drive unit to offer an unparalleled gear range and smooth, almost effortless e-power assistance – and the powerful Shimano four-piston hydraulic disc brakes ensure you're always in full control. We chose a RockShox Recon air suspension fork for its easy adjustability and ability to seamlessly smooth out the trail ahead, and extra-wide 2.6in Schwalbe tyres on fast-rolling 29er rims provide all the grip and cushioning you need, wherever your curiosity happens to take you. There's even scope to upgrade to a dropper post for the simplest possible way to mount and dismount. All of which goes to show that the answer to our original question is simply that, until now, we hadn't designed one. But now we have...

- ★ **332852** Cube Nuride Hybrid EXC 625 green 'n' sharpgreen 2020
- 332851** Cube Nuride Hybrid EXC 500 green 'n' sharpgreen 2020
- 332802** Cube Nuride Hybrid EXC 625 grey 'n' black 2020
- 332801** Cube Nuride Hybrid EXC 500 grey 'n' black 2020

**FRAME** Aluminum Superlite, Agile Comfort Geometry, Full Integrated Battery, Kickstand/Fender/Carrier Mounting Points  
**SIZE** Easy Entry: 46, 50, 54, 58  
**FORK** RockShox Recon RL Air, Tapered, 15x110mm, eMTB Approved, 100mm

**DRIVE UNIT** Bosch Drive Unit Performance CX Generation 4 (75Nm) Cruise (250Watt)  
**BATTERY** Bosch PowerTube 625  
**DISPLAY** Bosch Intuvia  
**CHARGER** Bosch 4A

**HEADSET** SA Orbit 1.5B ZS, Head Block System, Top Zero-Stack 1 1/8" [OD 44mm], Bottom Zero-Stack 1 1/2" [OD 56mm]  
**STEM** Statori Up2 Plus, 31.8mm, Adjustable  
**HANDLEBAR** CUBE Comfort Trail Bar, 720mm  
**GRIPS** Natural Fit All Terrain  
**REAR DERAILLEUR** Sram SX Eagle™, 12-Speed  
**SHIFTERS** Sram SX Eagle™ Trigger, Single Click  
**BRAKE SYSTEM** Shimano BR-MT420, Hydr. Disc Brake (180/180)  
**CRANKSET** Acid E-Crank, 38T, 175mm  
**CASSETTE** Sram PG-1210 Eagle™, 11-50T  
**CHAIN** Sram SX Eagle™  
**RIMS** CUBE EX30, 32H, Disc, Tubeless Ready  
**FRONT HUB** Shimano HB-MT400-B, 15QR, Boost, Centerlock  
**REAR HUB** Shimano FH-TX505, QR, Centerlock  
**TYRES** Schwalbe Smart Sam, K-Guard, 2.60  
**PEDALS** CUBE PP MTB  
**SADDLE** Natural Fit Sequence+ Comfort  
**SEAT POST** CUBE Performance Post, 30.9mm  
**SEATCLAMP** CUBE Varioclose, 34.9mm

**WEIGHT** 4,7 kg

- SPARE PARTS#**
- 8002** CUBE Headset ORBIT 1.5E ZS + crown race 1 1/8"
  - 10148** CUBE Hanger #148 short version

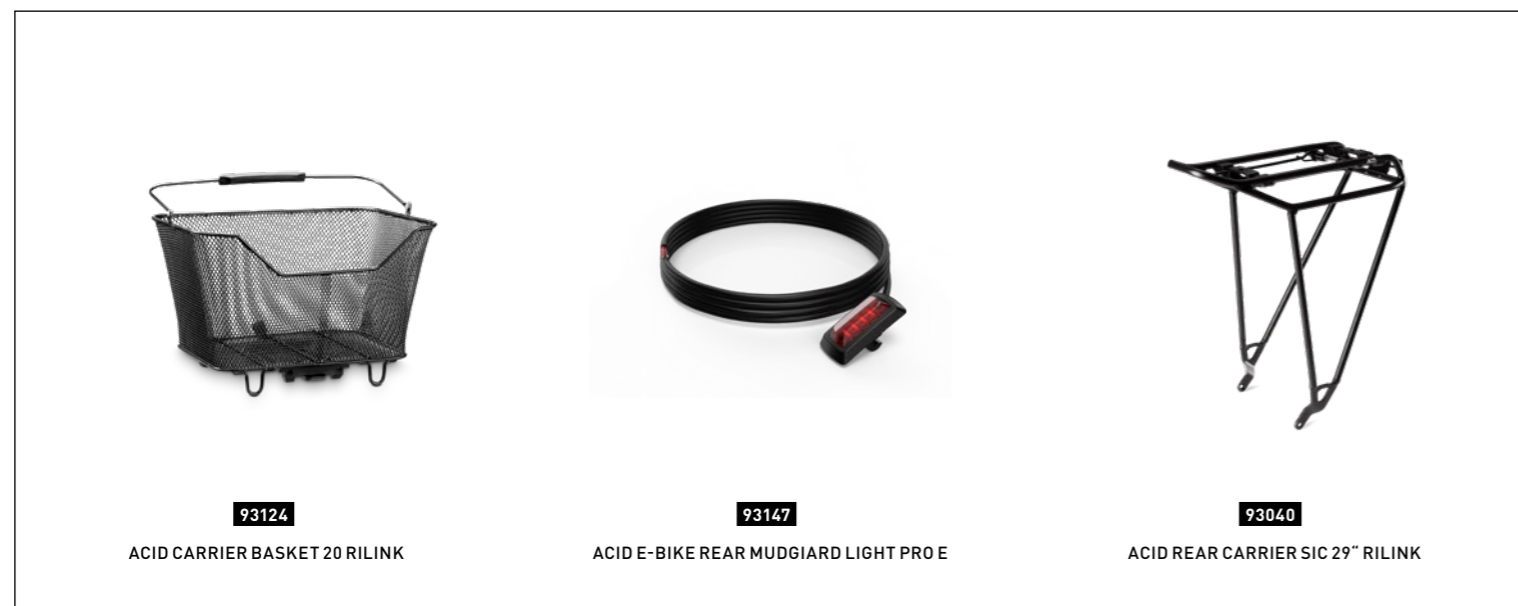

**93124**  
ACID CARRIER BASKET 20 RILINK

**93147**  
ACID E-BIKE REAR MUDGIARD LIGHT PRO E

**93040**  
ACID REAR CARRIER SIC 29" RILINK

# NURIDE HYBRID EXC ALLROAD

grey 'n' black



# NURIDE HYBRID EXC ALLROAD

green 'n' sharpgreen

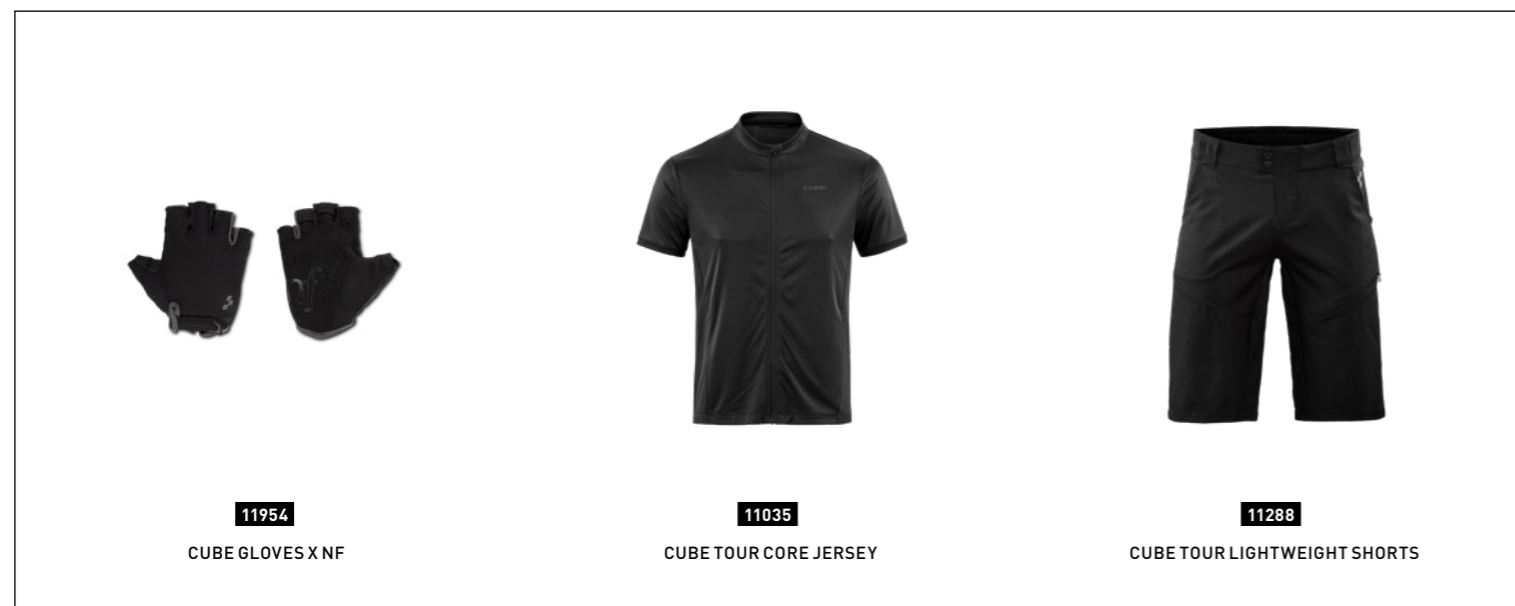

11954

CUBE GLOVES XNF



11035

CUBE TOUR CORE JERSEY



11288

CUBE TOUR LIGHTWEIGHT SHORTS

A bicycle is a versatile beast, a mountain bike even more so, and a 29er hybrid mountain bike powered by Bosch's fourth-generation CX drive unit arguably the most versatile of all. Our brand-new Nuride Hybrid EXC Allroad takes this exceptional versatility and dials it up a notch or two by adding an elegant Easy Entry frame and a full complement of accessories, so that it'll slot right into your life without the need to go out and spend more. Mudguards, a bright lighting system and an easy-to-use kickstand mean you're fully equipped for exploring the town, the countryside and beyond. Our new Modular Battery System gave our engineers the space they needed to include the option of a higher capacity Bosch power unit, to extend your range even further – and it also means the battery lives entirely inside the frame under an easy-access cover. With 12 easily selectable gears covering a huge range – thanks to Sram's SX Eagle transmission – you'll find that the smooth, refined Bosch power delivery will make every journey a pleasure – including the climbs. Powerful Shimano four-piston hydraulic disc brakes ensure you're always in complete control, whatever the weather conditions. And the RockShox Recon air suspension for fork and wide 2.35in Schwalbe tyres, combined with fast-rolling 29er wheels, provide a smooth ride and lots of grip for comfort and confidence. Add a Nuride Hybrid EXC Allroad to your life, and see where your next adventure takes you...



#### SPARE PARTS#

- 8002 CUBE Headset ORBIT 1.5E ZS + crown race 1 1/8"
- 10148 CUBE Hanger #148 short version



- 332872 Cube Nuride Hybrid EXC 625 Allroad green 'n' sharpgreen 2020
- 332871 Cube Nuride Hybrid EXC 500 Allroad green 'n' sharpgreen 2020
- 332862 Cube Nuride Hybrid EXC 625 Allroad grey 'n' black 2020
- 332861 Cube Nuride Hybrid EXC 500 Allroad grey 'n' black 2020



- FRAME#** Aluminum Superlite, Agile Comfort Geometry, Full Integrated Battery, Kickstand/Fender/Carrier Mounting Points
- SIZE#** Easy Entry: 46, 50, 54, 58
- FORK#** RockShox Recon RL Air, Tapered, 15x110mm, eMTB Approved, 100mm



- DRIVE UNIT#** Bosch Drive Unit Performance CX Generation 4 (75Nm) Cruise (250Watt)
- BATTERY#** Bosch PowerTube 625
- DISPLAY#** Bosch Intuvia
- CHARGER#** Bosch 4A



- HEADSET#** SA Orbit 1.5B ZS, Head Block System, Top Zero-Stack 1 1/8" [OD 44mm], Bottom Zero-Stack 1 1/2" [OD 56mm]
- STEM#** Satori Up2 Plus, 31.8mm, Adjustable
- HANDLEBAR#** CUBE Comfort Trail Bar, 720mm
- GRIPS#** Natural Fit All Terrain
- REAR DERAILLEUR#** Sram SX Eagle™, 12-Speed
- SHIFTERS#** Sram SX Eagle™ Trigger, Single Click
- BRAKE SYSTEM#** Shimano BR-MT420, Hydr. Disc Brake (180/180)
- CRANKSET#** Acid E-Crank, 38T, 175mm
- CASSETTE#** Sram PG-1210 Eagle™, 11-50T
- CHAIN#** Sram SX Eagle™
- RIMS#** CUBE EX30, 32H, Disc, Tubeless Ready
- FRONT HUB#** Shimano HB-MT400-B, 15QR, Boost, Centerlock
- REAR HUB#** Shimano FH-TX505, QR, Centerlock
- TYRES#** Schwalbe Smart Sam, K-Guard, 2.35
- PEDALS#** CUBE PP MTB
- SADDLE#** Natural Fit Sequence+ Comfort
- SEAT POST#** CUBE Performance Post, 30.9mm
- SEATCLAMP#** CUBE Varioclose, 34.9mm
- FRONT LIGHT#** Herrmans H-Black MR8, 6-12V, DC
- REAR LIGHT#** Busch&Müller Xeltec, DC
- KICKSTAND#** CUBEstand Cmp
- MUDGUARDS#** CID 65
- BELL#** Mini Bell



**WEIGHT#** 5,7 kg



# NURIDE HYBRID PRO

black'n'grey



# NURIDE HYBRID PRO

glacierblue'n'red



11276

CUBE TOUR JERSEY



16180

CUBE HELMET STEEP



13015

CUBE BOTTLE CAGE HPP

Here's a brand-new concept from CUBE: the Nuride Hybrid Pro is a fully equipped e-MTB powered by Bosch's fourth-generation CX drive system, but with an Easy Entry frame. After all, we figured there are riders who want the go-anywhere versatility and comfort of a 29er mountain bike, but also the ease of use of a frame that doesn't have a top tube. Good idea, right? We fitted a Suntour suspension fork with 100mm of travel to help smooth out the bumps, whilst wide 2.35in Schwalbe 29er tyres roll easily and add an extra dose of comfort. Shimano's easy-to-use Deore 10-speed gears work in harmony with the Bosch CX motor to whisk you along the road or trail, and we chose Shimano hydraulic disc brakes for their fantastic all-weather stopping ability. As for the frame, it's a bit of an engineering work of art. Featuring our new Modular Battery System, the immensely stiff and strong down tube houses the Bosch power unit under an easily accessed cover. It's neat and elegant, and – as with all our bikes – you have the peace of mind of knowing that it's passed our rigorous in-house safety tests with flying colours. There's also room for the option of a bigger capacity battery, for increased range. We even made the frame dropper post compatible, which makes mounting and dismounting as easy and straightforward as it could possibly be. Because what use is a bike, if it doesn't open up new horizons for you? The Nuride Hybrid Pro allows you to explore further than you ever thought possible. Where would you like it to take you tomorrow?

- ★ **332752** Cube Nuride Hybrid Pro 625 glacierblue'n'red 2020
- 332751** Cube Nuride Hybrid Pro 500 glacierblue'n'red 2020
- 332702** Cube Nuride Hybrid Pro 625 black'n'grey 2020
- 332701** Cube Nuride Hybrid Pro 500 black'n'grey 2020

**FRAME** Aluminum Superlite, Agile Comfort Geometry, Full Integrated Battery, Kickstand/Fender/Carrier Mounting Points  
**SIZE** Easy Entry: 46, 50, 54, 58  
**FORK** Suntour XCM ATB Coil, 100mm

**DRIVE UNIT** Bosch Drive Unit Performance CX Generation 4 (75Nm) Cruise (250Watt)  
**BATTERY** Bosch PowerTube 625  
**DISPLAY** Bosch Purion  
**CHARGER** Bosch 2A

**HEADSET** SA Orbit 1.5B ZS-R, Head Block System, Top Zero-Stack 1 1/8" (OD 44mm), Bottom Zero-Stack 1 1/2" (OD 56mm)  
**STEM** Satori Up2 Plus, 31.8mm, Adjustable  
**HANDLEBAR** CUBE Comfort Trail Bar, 720mm  
**GRIPS** Natural Fit All Terrain  
**REAR DERAILLEUR** Shimano Deore RD-M6000-GS, 10-Speed  
**SHIFTERS** Shimano Deore SL-M6000, Rapidfire-Plus  
**BRAKE SYSTEM** Shimano BR-MT200, Hydr. Disc Brake (180/180)  
**CRANKSET** Acid E-Crank, 38T, 175mm  
**CASSETTE** Shimano Deore CS-HG500, 11-42T  
**CHAIN** MC X10  
**RIMS** CUBE EX23, 32H, Disc, Tubeless Ready  
**FRONT HUB** Shimano HB-TX505, QR, Centerlock  
**REAR HUB** Shimano FH-TX505, QR, Centerlock  
**TYRES** Schwalbe Smart Sam, K-Guard, 2.35  
**PEDALS** CUBE PP MTB  
**SADDLE** Natural Fit Sequence Comfort  
**SEAT POST** CUBE Performance Post, 30.9mm  
**SEATCLAMP** CUBE Varioclose, 34.9mm

**WEIGHT** 4,6 kg

**SPARE PARTS**  
**8002** CUBE Headset ORBIT 1.5E ZS + crown race 1 1/8"  
**10148** CUBE Hanger #148 short version



# NURIDE HYBRID PRO ALLROAD

black'n'grey



# NURIDE HYBRID PRO ALLROAD

glacierblue'n'red



The Swiss Army invented the do-it-all pocket knife for a reason: it's a single tool for many jobs. You can think of the new Nuride Hybrid Pro Allroad in a similar way. A versatile, comfortable Bosch-powered e-MTB with 29er wheels and a full range of accessories, it's the Easy Entry hybrid mountain bike for everyone. We understand that you may want your bike to fulfil many roles, from weekend explorer to weekday runabout. That's why we equipped the Nuride Hybrid Pro Allroad with a kickstand, mudguards and front and rear lights – so that it'll fit seamlessly into your life. The frame features our brilliant new Easy Entry 29er design, complete with Modular Battery System and integrated cable routing for long-lasting, smooth gear shifts and minimal maintenance. There's room under the easily accessed cover for the option of a larger capacity battery, significantly increasing your range. Easy-to-use Shimano 10-speed gears function seamlessly with the new Bosch CX drive unit to give you the power and range you need to explore further, while Shimano's powerful hydraulic disc brakes stop reliably in all weathers. We fitted a Suntour suspension fork with 100mm of bump-absorbing travel for greater comfort, and fast-rolling 2.35in Schwalbe tyres offer loads of grip and plenty of cushioning. As far as we know, the Swiss Army doesn't use e-bikes. But if they did, we like to think it'd be this one...

- ★ **332772** Cube Nuride Hybrid Pro 625 Allroad glacierblue'n'red 2020
- 332771** Cube Nuride Hybrid Pro 500 Allroad glacierblue'n'red 2020
- 332762** Cube Nuride Hybrid Pro 625 Allroad black'n'grey 2020
- 332761** Cube Nuride Hybrid Pro 500 Allroad black'n'grey 2020

**FRAME** Aluminum Superlite, Agile Comfort Geometry, Full Integrated Battery, Kickstand/Fender/Carrier Mounting Points  
**SIZE** Easy Entry: 46, 50, 54, 58  
**FORK** Suntour XCM ATB Coil, 100mm

**DRIVE UNIT** Bosch Drive Unit Performance CX Generation 4 (75Nm) Cruise (250Watt)  
**BATTERY** Bosch PowerTube 625  
**DISPLAY** Bosch Purion  
**CHARGER** Bosch 2A

**HEADSET** SA Orbit 1.5B ZS-R, Head Block System, Top Zero-Stack 1 1/8" [OD 44mm], Bottom Zero-Stack 1 1/2" [OD 56mm]  
**STEM** Satori Up2 Plus, 31.8mm, Adjustable  
**HANDLEBAR** CUBE Comfort Trail Bar, 720mm  
**GRIPS** Natural Fit All Terrain  
**REAR DERAILLEUR** Shimano Deore RD-M6000-GS, 10-Speed  
**SHIFTERS** Shimano Deore SL-M6000, Rapidfire-Plus  
**BRAKE SYSTEM** Shimano BR-MT200, Hydr. Disc Brake (180/180)  
**CRANKSET** Acid E-Crank, 38T, 175mm  
**CASSETTE** Shimano Deore CS-HG500, 11-42T  
**CHAIN** MC X10  
**RIMS** CUBE EX23, 32H, Disc, Tubeless Ready  
**FRONT HUB** Shimano HB-TX505, QR, Centerlock  
**REAR HUB** Shimano FH-TX505, QR, Centerlock  
**TYRES** Schwalbe Smart Sam, K-Guard, 2.35  
**PEDALS** CUBE PP MTB  
**SADDLE** Natural Fit Sequence Comfort  
**SEAT POST** CUBE Performance Post, 30.9mm  
**SEATCLAMP** CUBE Varioclose, 34.9mm  
**FRONT LIGHT** CUBE Shiny 50 Lux, 6-12V, DC  
**REAR LIGHT** Busch&Müller Xeltec, DC  
**KICKSTAND** CUBEstand Cmp  
**MUDGUARDS** ACID 65  
**BELL** Mini Bell

**SPARE PARTS**  
**8002** CUBE Headset ORBIT 1.5E ZS + crown race 1 1/8"  
**10148** CUBE Hanger #148 short version

**WEIGHT** 5,6 kg



**17091**  
CUBE SHOES ATX LOXIA PRO



**11967**  
CUBE GLOVES WS X NF



**11061**  
SQUARE JERSEY PERFORMANCE

---

## FOR us #Adventurers

---

Our engineering team puts the same effort into every frame design, whether it's a range-topping race machine or an entry-level commuter. That's why we gave the Acid Hybrid an aluminium Superlite chassis with double-butted tubes, which shave weight where it isn't needed and add extra thickness where strength is important. Advanced hydroforming is what gives it its sleek looks and the elegant, oversized down tube houses both the Bosch drive unit and the battery. Our acclaimed Agile Ride Geometry gives the Acid Hybrid easy, intuitive handling to keep you safe, whether you're exploring a trail or riding to the office. Internally routed cables – including for a future dropper post upgrade – keep everything tidy, reduce maintenance and ensure your gear shifts stay precise. And integrated mudguard mounts mean it's a cinch to fit full-length fenders to help keep you dry on the road, all year round.



# ACID HYBRID ONE 29

black 'n' green



# ACID HYBRID ONE 29

blue 'n' orange



Trapeze | black 'n' green



Trapeze | blue 'n' orange



Our evergreen Acid Hybrid ONE continues to set the standard for a versatile, affordable and rugged Bosch e-bike. Combining the rugged appeal of our mountain bikes with the comfort and adaptability of our touring machines, it's the go-anywhere two-wheeled companion that'll slot right into your life – and there's even a trapeze frame version, so everyone can find the perfect fit. The advanced hydroforming that enables our engineering team to build such an elegant, tough and rigid frame is also your guarantee of long-lasting safety and performance, thanks to the stringent standards of our in-house testing processes. The powerful and reliable Bosch drive unit, neatly contained in its own housing, is powered by the battery slotted neatly into the custom down tube. Working seamlessly with the wide-ranging, easy-to-use Shimano 9-speed gears, they provide quiet, unobtrusive and smooth assistance to back up your pedalling. Wide Schwalbe Smart Sam tyres – easily accommodated by a revised frame design with extra clearance – provide ample grip, easy rolling and smooth comfort on any surface. Our Natural Fit saddle and carefully selected bars, stem and grips ensure you'll be comfortable on any ride, long and short. Shimano's powerful MT200 hydraulic disc brakes serve up plenty of stopping power in all weathers, and the Suntour suspension fork adds 100mm of bump- and pothole-smoothing travel to the mix. From city streets and the daily commute to weekend off-road exploring, the Acid Hybrid ONE has got it all covered.

- ★ **333111** Cube Acid Hybrid ONE 500 29 blue 'n' orange 2020
- 333110** Cube Acid Hybrid ONE 400 29 blue 'n' orange 2020
- 333101** Cube Acid Hybrid ONE 500 29 black 'n' green 2020
- 333100** Cube Acid Hybrid ONE 400 29 black 'n' green 2020

**FRAME** Aluminium SuperLite, Advanced Hydroforming, Agile Ride Geometry, Double Butted, Tapered Headtube, Internal Cable Routing, Full Integrated Battery, Kickstand/Fender/Carrier Mounting Points  
**SIZE** #5", 17", 19", 21", 23", Trapeze: 15", 17", 19"  
**FORK** SR Suntour XCM ATB Coil, 100mm

**DRIVE UNIT** Bosch Drive Unit Performance Generation 3 (65Nm) Cruise (250Watt)  
**BATTERY** Bosch PowerPack 500  
**DISPLAY** Bosch Purion  
**CHARGER** Bosch 2A

**HEADSET** #SA Orbit 1.5B ZS-R, Top Zero-Stack 1 1/8" (OD 44mm), Bottom Zero-Stack 1 1/2" (OD 56mm)  
**STEM** #CUBE Performance Stem Pro, 31.8mm  
**HANDLEBAR** #CUBE Rise Trail Bar, 700mm  
**GRIPS** #CUBE Performance Grip  
**REAR DERAILLEUR** #Shimano Deore RD-M592-SGS, 9-Speed  
**SHIFTERS** #Shimano SL-M2010-9R, Rapidfire-Plus  
**BRAKE SYSTEM** #Shimano BR-MT200, Hydr. Disc Brake (180/180)  
**CRANKSET** #SA CK-602, 38T, 175mm  
**CASSETTE** #Shimano CS-HG201, 11-36T  
**CHAIN** #MC X9  
**RIMS** #CUBE EX23, 32H, Disc, Tubeless Ready  
**FRONT HUB** #Shimano HB-TX505, QR, Centerlock  
**REAR HUB** #Shimano FH-TX505, QR, Centerlock  
**TYRES** #Schwalbe Smart Sam, K-Guard, 2.35  
**PEDALS** #CUBE PP MTB  
**SADDLE** #Natural Fit Sequence  
**SEAT POST** #CUBE Performance Post, 30.9mm  
**SEATCLAMP** #CUBE Varioclose, 34.9mm

**WEIGHT** #2,1 kg

**SPARE PARTS#**  
**10148** CUBE Hanger #148 short version  
**10338** CUBE Headset Orbit 1.5E ZS 1 1/8 / 1.5 semi + 1 1/8 crown race



**11402**  
SQUARE JERSEY ACTIVE



**12109**  
CUBE BACKPACK EDGE TRAIL



**92950**  
ACID MUDGUARD VANE DISC REAR 29"

# ACID HYBRID ONE ALLROAD 29

Trapeze | black 'n' green



# ACID HYBRID ONE ALLROAD 29

black 'n' green



At CUBE we're all about rising to the challenge. So, when faced with the idea of combining the go-anywhere versatility of a mountain bike, the practical flexibility of a tourer and the ease-of-use of a Bosch e-bike, our engineering team didn't flinch – they got to work instead. The result is the Acid Hybrid ONE Allroad. We call it cross-mountain, and we reckon it's the perfect setup for busy folk looking for a bike that'll fit easily into their lives. For commuting we've equipped it with full-length mudguards, front and rear lights powered by the Bosch battery, a bell and a kickstand. Just jump on, and the office is a sweat-free ride away. For weekend adventuring the Suntour suspension fork, grippy and wide Schwalbe tyres, smooth Shimano 9-speed gears and powerful Shimano MT200 hydraulic disc brakes are all you need to explore off the beaten path. And, of course, it's all powered by Bosch's reliable, smooth and eerily quiet drive unit and battery, sleekly incorporated into the elegant frame design in such a way that you'll forget it's there. Double butting and advanced hydroforming have allowed our designers to shave weight wherever possible and add extra strength where it's needed, with the added reassurance of the Acid Hybrid ONE Allroad's frame having passed all of our extremely tough in-house safety tests. Combined with our Agile Ride Geometry, it's a combination that ensures safe, predictable handling in any situation from busy city streets to deserted forest trails. Jump on and ride wherever you fancy, because the Acid Hybrid ONE Allroad has got you covered.

- ★ **333151** Cube Acid Hybrid ONE 500 Allroad 29 black 'n' green 2020
- ★ **333150** Cube Acid Hybrid ONE 400 Allroad 29 black 'n' green 2020

**FRAME** Aluminium Superlite, Advanced Hydroforming, Agile Ride Geometry, Double Butted, Tapered Headtube, Internal Cable Routing, Full Integrated Battery, Kickstand/Fender/Carrier Mounting Points  
**SIZE** #5", 17", 19", 21", 23", Trapeze: 15", 17", 19"  
**FORK** #R Suntour XCM ATB Coil, 100mm

**DRIVE UNIT** #B Bosch Drive Unit Performance Generation 3 (65Nm) Cruise (250Watt)  
**BATTERY** #B Bosch PowerPack 500  
**DISPLAY** #B Bosch Purion  
**CHARGER** #B Bosch 2A

**HEADSET** #SA Orbit 1.5B ZS-R, Top Zero-Stack 1 1/8" (OD 44mm), Bottom Zero-Stack 1 1/2" (OD 56mm)  
**STEM** #CUBE Performance Stem Pro, 31.8mm  
**HANDLEBAR** #CUBE Rise Trail Bar, 700mm  
**GRIPS** #CUBE Performance Grip  
**REAR DERAILLEUR** #Shimano Deore RD-M592-SGS, 9-Speed  
**SHIFTERS** #Shimano SL-M2010-9R, Rapidfire-Plus  
**BRAKE SYSTEM** #Shimano BR-MT200, Hydr. Disc Brake (180/180)  
**CRANKSET** #SA CK-602, 38T, 175mm  
**CASSETTE** #Shimano CS-HG201, 11-36T  
**CHAIN** #MC X9  
**RIMS** #CUBE EX23, 32H, Disc, Tubeless Ready  
**FRONT HUB** #Shimano HB-TX505, QR, Centerlock  
**REAR HUB** #Shimano FH-TX505, QR, Centerlock  
**TYRES** #Schwalbe Smart Sam, K-Guard, 2.35  
**PEDALS** #CUBE PP MTB  
**SADDLE** #Natural Fit Sequence  
**SEAT POST** #CUBE Performance Post, 30.9mm  
**SEATCLAMP** #CUBE Varioclose, 34.9mm  
**FRONT LIGHT** #XA Compactline 20, 6-12V, DC  
**REAR LIGHT** #Busch&Müller Xeltec, DC  
**KICKSTAND** #CUBEstand Cmp  
**MUDGUARDS** #ACID 65  
**BELL** #Mini Bell

**WEIGHT** #3,1 kg

**SPARE PARTS**  
**10148** CUBE Hanger #148 short version  
**10338** CUBE Headset Orbit 1.5E ZS 1 1/8 / 1.5 semi + 1 1/8 crown race

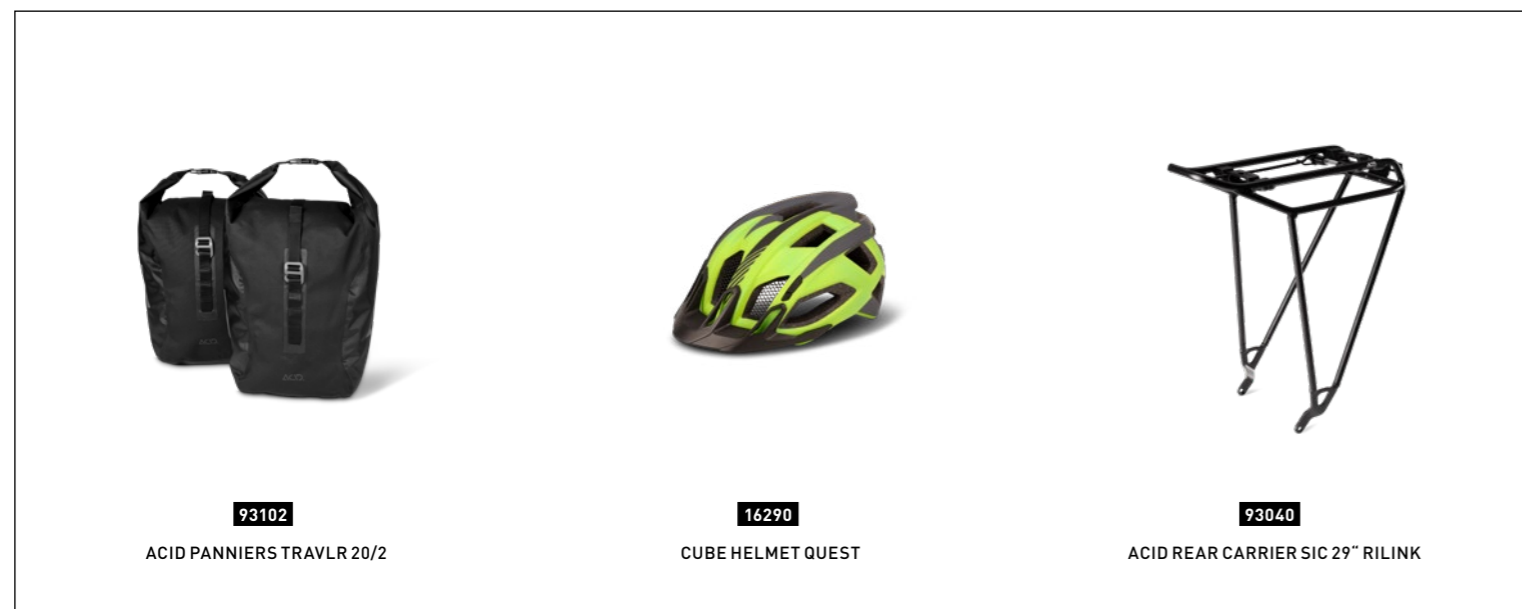

**93102**  
ACID PANNIERS TRAVLR 20/2

**16290**  
CUBE HELMET QUEST

**93040**  
ACID REAR CARRIER SIC 29" RILINK

F U L L  
S P S I O  
U E O  
S N N



	COMFORT	TRAIL	ALL MOUNTAIN	ENDURO
088 <b>STEREO 160 HPC</b>   27.5			█	█
102 <b>STEREO 140 HPC</b>   29		█	█	█
122 <b>STEREO 120 HPA</b>   29	█	█		

**STEREO 160**

Enduro, redefined and redesigned. Race-bred and tested and powered by a sleekly integrated, fourth generation Bosch system, the Stereo Hybrid 160 means you can ride further, faster and steeper than ever before. 100% enduro, 100% perfected. And now better than ever.

**STEREO 140**

Ride all mountain, all the time. The completely revised Stereo Hybrid 140 is a new all mountain benchmark, combining the go-anywhere potential of 140mm of smooth travel with 29er wheels, nimble handling and the power boost of Bosch's superb fourth generation drive system. Push your boundaries....

**STEREO 120**

Expand your horizons. Sleek, comfortable and amazingly capable, the new Stereo Hybrid 120 is your weekend ticket to adventure. Built around our acclaimed Stereo 120 suspension design, the seamless addition of fourth generation Bosch power adds more adventure to the mix. Ride the dream.

## FOR us #EnduroPilots

Some people laughed when we said we could build a hybrid enduro bike capable of taking on the world's toughest EWS trails. Well, they're not laughing now. The new Stereo Hybrid 160 HPC rewrites the rules, blending the big-hit ability of a dialled big-mountain machine with the ride-anywhere versatility of Bosch's fourth-generation drive system. There's literally no mountain too high, or too steep, for this bike. Key to its success is a brand-new main frame constructed from carbon. The versatility of this material allowed our engineers to create an entirely new setup – the Modular Battery System – to house the Bosch power unit entirely within the down tube. Hidden by a double-layer cover with shock protection, push-button access and a hidden lock, the new system has freed up enough space for the Stereo Hybrid 160 HPC to accommodate a larger capacity 625Wh battery, for significantly extended range – so you can ride further, higher and faster, confident that you've got the juice to keep going. The trunion shock mount, big bearings and Boost 148 rear axle of the aluminium rear triangle work with the 1.5in head tube to deliver efficient power transfer and millimetre-perfect steering precision, whilst aggressive geometry gives you the advantage you need to show the trails exactly who's boss. We even remembered to add a bottle cage mount and make it chain guide compatible, so you can tailor your Stereo Hybrid 160 HPC exactly the way you want it. Enduro is exciting, but Bosch hybrid power takes it to a new level. Are you up for it?



# STEREO HYBRID 160 HPC SLT 27.5

carbon'n'red



Top-level performance demands top-level components. At CUBE we understand that – it's the reason we developed the Stereo Hybrid 160 HPC SLT. An enduro hybrid built to perform at the highest level, it combines the rock-solid handling and refined, progressive suspension kinematics of our new Stereo Hybrid 160 HPC frame with a wish-list of components that would have even the most pampered of factory team riders salivating. Sram's new X01 Eagle AXS wireless transmission sets new standards for gear range, simplicity and functionality, pairing seamlessly with Bosch's awesome fourth-generation CX drive unit to deliver smooth, pedal-assisting torque to the rear wheel. Thanks to our new Modular Battery System, the CUBE engineering team was able to make room inside the down tube for an even higher capacity Bosch power unit, ensuring that you've got the range you need for longer days out in the mountains. The RockShox Super Deluxe Ultimate shock and matching Lyrik Ultimate fork perform as well as you'd expect from their names, serving up huge amounts of plush, progressive, rock-swallowing travel and keeping the light, tough Newmen Advanced wheels and extra-wide Schwalbe 2.6in Super Gravity tyres firmly anchored to the ground, except when you don't want them to be. Backing up all this stellar control is a RaceFace cockpit, wireless Reverb Stealth AXS dropper post and powerful four-piston Magura MT7 hydraulic disc brakes running on oversized 203mm rotors. With frame, Bosch drive system and Sram transmission components working this flawlessly together, there's no trail you won't be able to tackle. Faster, higher, longer – the Stereo Hybrid 160 HPC SLT will take you there.

★ **337302** CUBE Stereo Hybrid 160 HPC SLT 27.5 625 carbon'n'red 2020

**FRAME#** 62 Monocoque Advanced Twin Mold Technology, Aluminum 6061 T6 Rear Triangle, Efficient Trail Control, FSP 4-Link, Agile Trail Geometry, Boost 148, Full Integrated Battery  
**SIZE#** 6", 18", 20", 22"  
**FORK#** RockShox Lyrik Ultimate RC2, 15x110mm, eMTB Approved, 170mm  
**SHOCK#** RockShox Super Deluxe Ultimate, 205x60mm, Trunnion Mount  
**SHOCK HARDWARE#** Top: 54mm Trunnion Mount, Bottom: 22.2x8mm

**DRIVE UNIT#** Bosch Drive Unit Performance CX Generation 4 (75Nm) Cruise (250Watt)  
**BATTERY#** Bosch PowerTube 625  
**DISPLAY#** Bosch Kiox  
**CHARGER#** Bosch 4A

**HEADSET#** SA Orbit Z 1.5E ZS, Top Zero-Stack 1 1/2" (OD 56mm), Bottom Zero-Stack 1 1/2" (OD 56mm)  
**STEM#** Race Face Turbine R 35  
**HANDLEBAR#** Race Face Next R 35 Carbon, 800mm  
**GRIPS#** CUBE Race Grip 31mm, 1-Clamp  
**REAR DERAILLEUR#** Sram X01 Eagle AXS™, 12-Speed  
**SHIFTERS#** Sram Eagle AXS™ Controllor  
**BRAKE SYSTEM#** Magura MT7, Hydr. Disc Brake (203/203)  
**CRANKSET#** \*thirteen Plus Crank, 36T, 165mm  
**CASSETTE#** Sram XG-1299 Rainbow, 10-50T  
**CHAIN#** Sram PC-X01 Eagle™  
**CHAIN GUIDE#** \*thirteen Plus e\*spec  
**WHEELSET#** Newmen Advanced SL E.30, 28/28 Spokes, 15x110mm/12x148mm, Tubeless Ready  
**FRONT TIRE#** Schwalbe Magic Mary Kevlar, Addix Soft, Super Gravity, Tubeless Easy, 2.60  
**REAR TIRE#** Schwalbe Hans Dampf Kevlar, Addix Speedgrip, Super Gravity, Tubeless Easy, 2.60  
**SADDLE#** Natural Fit Nuance SLT  
**SEAT POST#** RockShox Reverb AXS™ 31.6mm (16": 340x100mm; 18": 390x125mm; 20", 22": 440x150mm)  
**SEATCLAMP#** CUBE Srewlock Semi Integrated, 34.9mm

**SPARE PARTS#**  
**8000** CUBE Headset Orbit Z 1.5E ZS  
**8528** CUBE BEARING\_pivot set-Ø15x87.4 (18-02089)  
**8529** CUBE AXLE\_pivot set-shock mount (18-02849)  
**8539** CUBE BEARING\_pivot set-Ø10x23,5  
**8540** CUBE BEARING\_pivot set-horst link  
**8651** CUBE HANGER\_mtb-x12-std-2020 (18-05516)

**WEIGHT#** 2,6 kg



10723

CUBE SHOES GTY MAZE



10684

CUBE AM JERSEY



16240

CUBE HELMET BADGER





FULLSUSPENSION

Anyone who tells you that pros don't ride e-bikes has got it wrong. Case in point: the all-new Stereo Hybrid 160 HPC Actionteam. Decked out with a full complement of team issue components and race-tested kit, it combines the mountain-taming, race-proven ability of our enduro bikes with the smooth power delivery and extended versatility of Bosch's fourth-generation drive system. Wish-list parts include Fox Factory shocks – a Float DPX2 Factory at the rear, combined with a 36 Float Factory fork at the front for buttery smooth, progressive and controllable travel in any riding situation – and a Fox Transfer Factory dropper post. There's a Shimano 12-speed transmission with XT derailleur and shifters, offering the widest possible gear range and unmatched reliability. Matching Shimano XT hydraulic disc brakes clamp to 203mm rotors for added cooling and ultimate power and control on even the longest, steepest descents, whilst light and strong Newmen rims wrapped with Schwalbe's Magic Mary and Hans Dampf Super Gravity 2.6in tyres grip tenaciously to the trail. Bosch's smooth, powerful, Kiox-controlled CX drive unit sits in a housing accessed by a single-bolt cover, and the high-capacity power unit – for extended range – is housed in the down tube behind a shock-, moisture- and dust-proof cover. Hidden cable routing, chain guide compatibility, oversized bearings and the proven strength and durability of our carbon main frame – tested rigorously by our own in-house torture testing lab – are the finishing touches that help make the difference. With aggressive geometry designed around 170mm forks and riders who aren't afraid to push their limits, we've covered all the bases to build an enduro e-bike that establishes a completely new benchmark for performance. Our pros know it. And it's available for you to discover, too.

★ **337252** Cube Stereo Hybrid 160 HPC Actionteam 27.5 625 actionteam 2020

**FRAME** #62 Monocoque Advanced Twin Mold Technology, Aluminum 6061 T6 Rear Triangle, Efficient Trail Control, FSP 4-Link, Agile Trail Geometry, Boost 148, Full Integrated Battery  
**SIZE** #6", 18", 20", 22"  
**FORK** #Fox 36 Float Factory FIT4, 3-Position w/Low Speed Compression Adjust, Tapered, 15x110mm, E-Bike Tune, 170mm, Kashima Coated  
**SHOCK** #Fox Float DPX2 Factory EVOL, Open(Adjustable)/Medium/Firm Mode, 205x60mm, Trunnion Mount, Kashima Coated  
**SHOCK HARDWARE** #op: 54mm Trunnion Mount, Bottom: 22.2x8mm

**DRIVE UNIT** #Bosch Drive Unit Performance CX Generation 4 (75Nm) Cruise (250Watt)  
**BATTERY** #Bosch PowerTube 625  
**DISPLAY** #Bosch Kiox  
**CHARGER** #Bosch 4A

**HEADSET** #SA Orbit Z 1.5E ZS, Top Zero-Stack 1 1/2" (OD 56mm), Bottom Zero-Stack 1 1/2" (OD 56mm)  
**STEM** #Race Face Turbine R 35  
**HANDLEBAR** #Race Face Next R 35 Carbon, 800mm  
**GRIPS** #CUBE Race Grip 31mm, 1-Clamp  
**REAR DERAILLEUR** #Shimano XT RD-M8100-SGS, ShadowPlus, 12-Speed  
**SHIFTERS** #Shimano XT SL-M8100-IR, Direct Attach  
**BRAKE SYSTEM** #Shimano XT BR-M8120, Hydr. Disc Brake (203/203)  
**CRANKSET** #thirteen Plus Crank, 36T, 165mm  
**CASSETTE** #Shimano SLX CS-M7100, 10-51T  
**CHAIN** #Shimano SLX CN-M7100  
**CHAIN GUIDE** #thirteen Plus e\*spec  
**RIMS** #Newmen Evolution SL E.35, 28H, Disc, Tubeless Ready  
**FRONT HUB** #Shimano XT HB-M8110-B, 15QR, Boost, Centerlock  
**REAR HUB** #Shimano XT FH-M8110-B, 12mm, Boost, Centerlock  
**FRONT TIRE** #Schwalbe Magic Mary Kevlar, Addix Soft, Super Gravity, Tubeless Easy, 2.60  
**REAR TIRE** #Schwalbe Hans Dampf Kevlar, Addix Speedgrip, Super Gravity, Tubeless Easy, 2.60  
**SADDLE** #Natural Fit Venec  
**SEAT POST** #Fox Transfer Factory 31.6mm, Kashima Coated (16": 359x100mm; 18": 409x125mm; 20", 22": 456x150mm)  
**SEATCLAMP** #CUBE Srewlock Semi Integrated, 34.9mm

**SPARE PARTS**  
**8000** CUBE Headset Orbit Z 1.5E ZS  
**8528** CUBE BEARING\_pivot set-Ø15x87.4 (18-02089)  
**8529** CUBE AXLE\_pivot set-shock mount (18-02849)  
**8539** CUBE BEARING\_pivot set-Ø10x23,5  
**8540** CUBE BEARING\_pivot set-horst link  
**8651** CUBE HANGER\_mtb-x12-std-2020 (18-05516)

**WEIGHT** #3,5 kg

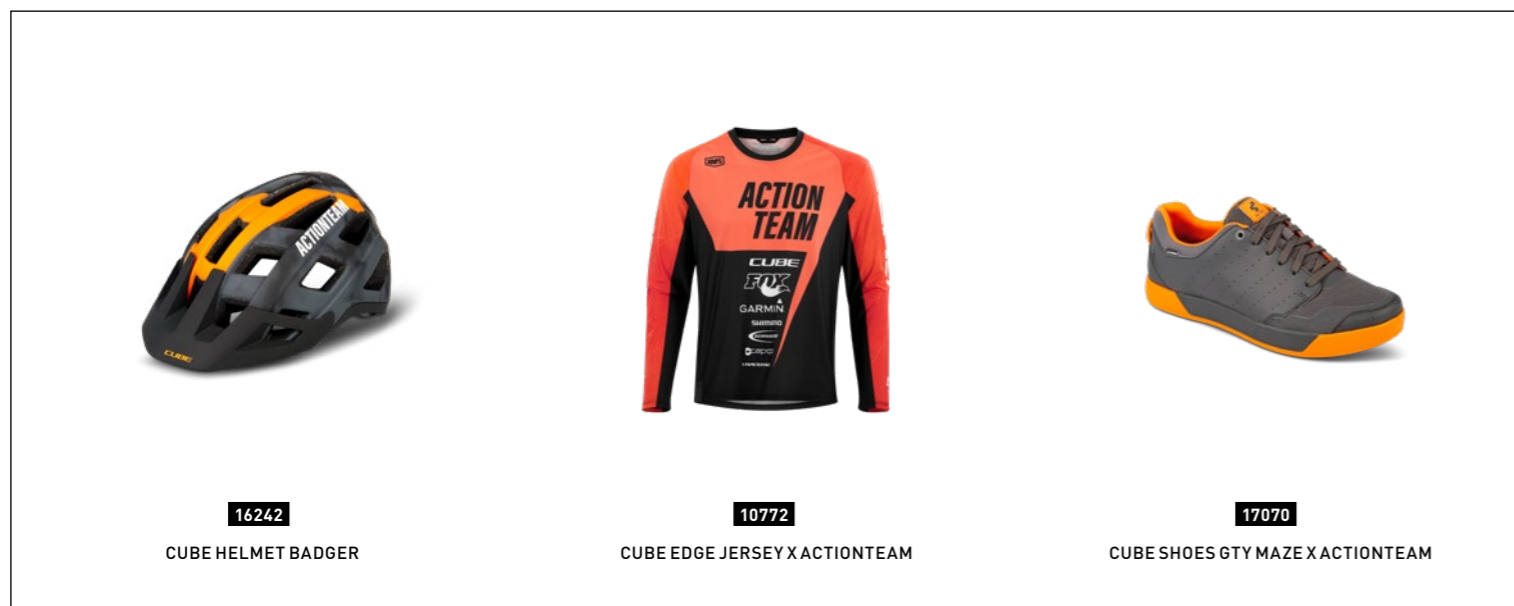

**16242**  
CUBE HELMET BADGER

**10772**  
CUBE EDGE JERSEY X ACTIONTEAM

**17070**  
CUBE SHOES GTY MAZE X ACTIONTEAM



# STEREO HYBRID 160 HPC TM 27.5

grey'n'orange

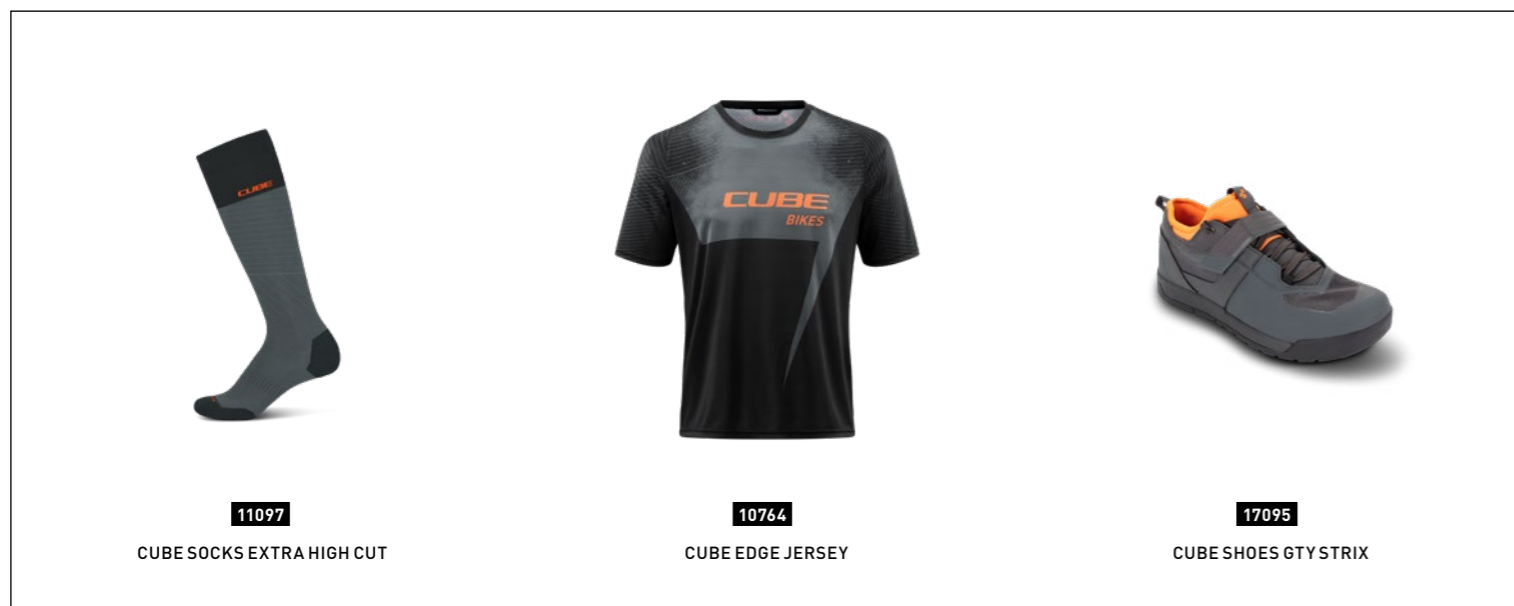

11097  
CUBE SOCKS EXTRA HIGH CUT

10764  
CUBE EDGE JERSEY

17095  
CUBE SHOES GTY STRIX

Do you even enduro, bro? The brand-new Stereo Hybrid 160 HPC TM means you've no excuse not to. Combining the smooth, tractable power of Bosch's fourth-generation drive system with a box-fresh frame, Fox suspension and Sram's 12-speed transmission, it's got the aggressive geometry and progressive suspension kinematics you need to smash the descents and the gear range and power to get you back up the climbs faster than ever. We threw all our Enduro World Series experience at the new frame design, combined with our engineering team's carbon construction know-how and years of figuring out how to get the best from Bosch's drive systems. The result is pretty special. The carbon main frame's Modular Battery System hides the Bosch power unit inside the down tube, protected from impact, dirt and water ingress by a shock-resistant, quick-release cover with a built-in, hidden lock. It's not just neat, it's also a higher capacity battery than before, which means you can ride further, faster and harder than before. The Boost 148 rear end, oversized bearings and large 1.5in steerer all contribute to razor-sharp handling, no matter how hard you ride. And there's even room for a bottle cage mount, so you can pack extra hydration or a tool kit for those long days out in the mountains. A Fox Float DPX2 Performance shock with trunnion mount pairs with a Fox 36 Float Performance fork for controlled, smooth and progressive boulder-chewing suspension performance, while Magura's MT7 hydraulic disc brakes with 203mm rotors and Schwalbe Magic Mary and Hans Dampf Super Gravity tyres running on Fulcrum E-Metal wheels ensure you're always in full control. And as for drive, you've got seamless Bosch assistance delivered via Sram's positive-shifting, wide-ranging NX Eagle 12-speed gearbox. We even included a remote dropper post, so you're all out of excuses for not riding that new, tight and steep line. Add it all up and it means one thing: the Stereo Hybrid 160 HPC TM has got your back, bro.

★ 337152 Cube Stereo Hybrid 160 HPC TM 625 27.5 grey'n'orange 2020

**FRAME#** 62 Monocoque Advanced Twin Mold Technology, Aluminum 6061 T6 Rear Triangle, Efficient Trail Control, FSP 4-Link, Agile Trail Geometry, Boost 148, Full Integrated Battery  
**SIZE#** 6", 18", 20", 22"  
**FORK#** Fox 36 Float GRIP, 3-Position w/Micro Adjust, Tapered, 15x110mm, E-Bike Tune, 170mm  
**SHOCK#** Fox Float DPX2 EVOL, 205x60mm, Open(Adjustable)/Medium/Firm Mode, Trunnion Mount  
**SHOCK HARDWARE#** Top: 54mm Trunnion Mount, Bottom: 22.2x8mm

**DRIVE UNIT#** Bosch Drive Unit Performance CX Generation 4 (75Nm) Cruise (250Watt)  
**BATTERY#** Bosch PowerTube 625  
**DISPLAY#** Bosch Kiox  
**CHARGER#** Bosch 4A

**HEADSET#** SA Orbit Z 1.5E ZS, Top Zero-Stack 1 1/2" (OD 56mm), Bottom Zero-Stack 1 1/2" (OD 56mm)  
**STEM#** CUBE Performance Stem E-MTB, 31.8mm  
**HANDLEBAR#** Newmen Evolution SL 318.25, 800mm  
**GRIPS#** CUBE Race Grip 31mm, 1-Clamp  
**REAR DERAILLEUR#** Sram NX Eagle™, 12-Speed  
**SHIFTERS#** Sram NX Eagle™ Trigger, Single Click  
**BRAKE SYSTEM#** Magura MT7, Hydr. Disc Brake (203/203)  
**CRANKSET#** \*thirteen Plus Crank, 36T, 165mm  
**CASSETTE#** Sram XG-1275, 10-50T  
**CHAIN#** Sram NX Eagle™  
**CHAIN GUIDE#** \*thirteen Plus e\*spec  
**WHEELSET#** Fulcrum E-Metal 700, 28/28 Spokes, 15x110mm/12x148mm, Tubeless Ready  
**FRONT TIRE#** Schwalbe Magic Mary Kevlar, Addix Soft, Super Gravity, Tubeless Easy, 2.60  
**REAR TIRE#** Schwalbe Hans Dampf Kevlar, Addix Speedgrip, Super Gravity, Tubeless Easy, 2.60  
**SADDLE#** Natural Fit Venec  
**SEAT POST#** CUBE Dropper Post, Handlebar Lever, Internal Cable Routing, 31.6mm (16": 370x100mm, 18": 420x125mm, 20": 22": 480x150mm)  
**SEATCLAMP#** CUBE Srewlock Semi Integrated, 34.9mm

**SPARE PARTS#**  
**8000** CUBE Headset Orbit Z 1.5E ZS  
**8528** CUBE BEARING\_pivot set-Ø15x87.4 (18-02089)  
**8529** CUBE AXLE\_pivot set-shock mount (18-02849)  
**8539** CUBE BEARING\_pivot set-Ø10x23,5  
**8540** CUBE BEARING\_pivot set-horst link  
**8651** CUBE HANGER\_mtb-x12-std-2020 (18-05516)

**WEIGHT#** 3,9 kg

FULLSUSPENSION

# STEREO HYBRID 160 HPC SL 27.5

glacierblue'n'orange



17072  
CUBE SHOES MTB PEAK

10779  
CUBE AM WS JERSEY

12117  
CUBE BACKPACK EDGE TRAIL X ACTIONTEAM

Welcome to the all-new Stereo Hybrid 160 HPC SL – a bike that redefines what's possible. Building a world-beating enduro bike isn't easy. Building one that combines genuine enduro performance with the ease of use of Bosch's amazing drive system is even harder. Luckily, CUBE's years of experience at the Enduro World Series, as well as building class-leading Bosch e-bikes, helps make the job a tiny bit easier. Our engineering team was able to draw on their extensive hybrid, carbon and full suspension design experience to create something remarkable: a 160mm travel bike with carbon main frame, progressive suspension kinematics and an aggressive geometry designed specifically for 170mm forks and tough enduro courses, plus seamless Bosch power. The new CUBE Modular Battery System encloses the Bosch power unit in the down tube, hidden behind a shock-, moisture- and dust-proof cover that features a push button for access, as well as a hidden lock. It's not just neat, it also enables us to increase the battery's capacity for even greater range out in the mountains. Larger bearings, hidden cable routing, chain guide compatibility and space for a bottle cage mount are just some of the details that set this bike apart. As for the spec, it would have been easy to cut a few corners... but that's not the CUBE way. So you'll find a RockShox Deluxe Select+ shock and matching RockShox Lyrik Select fork up front, working together to deliver up to 170mm of boulder-swallowing travel. A remote dropper post opens up new line choices, while Sram's NX Eagle 12-speed transmission ensures you can ride every bit of the link stages. And Magura MT Fifty hydraulic disc brakes, combined with big-volume and super-grippy Schwalbe Hans Dampf tyres, give you all the power you need to control your speed on the timed stages. Combined with Bosch's fourth-generation drive unit, it's all the excuse you need to head out into the mountains and smash out some new personal bests. Are you ready? Because the Stereo Hybrid 160 HPC SL definitely is.

SPARE PARTS#	
8000	CUBE Headset Orbit Z 1.5E ZS
8528	CUBE BEARING_pivot set-Ø15x87.4 (18-02089)
8529	CUBE AXLE_pivot set-shock mount (18-02849)
8539	CUBE BEARING_pivot set-Ø10x23,5
8540	CUBE BEARING_pivot set-horst link
8651	CUBE HANGER_mtb-x12-std-2020 (18-05516)

★ 337122 CUBE Stereo Hybrid 160 HPC SL 625 27.5 glacierblue'n'orange 2020

**FRAME#** 62 Monocoque Advanced Twin Mold Technology, Aluminum 6061 T6 Rear Triangle, Efficient Trail Control, FSP 4-Link, Agile Trail Geometry, Boost 148, Full Integrated Battery  
**SIZE#** 6", 18", 20", 22"  
**FORK#** RockShox Lyrik Select Charger RC, 15x110mm, eMTB Approved, 170mm  
**SHOCK#** RockShox Deluxe Select+, 205x60mm, Trunnion Mount  
**SHOCK HARDWARE#** Top: 54mm Trunnion Mount, Bottom: 22.2x8mm

**DRIVE UNIT#** Bosch Drive Unit Performance CX Generation 4 (75Nm) Cruise (250Watt)  
**BATTERY#** Bosch PowerTube 625  
**DISPLAY#** Bosch Purion  
**CHARGER#** Bosch 2A

**HEADSET#** SA Orbit Z 1.5E ZS, Top Zero-Stack 1 1/2" (OD 56mm), Bottom Zero-Stack 1 1/2" (OD 56mm)  
**STEM#** CUBE Performance Stem E-MTB, 31.8mm  
**HANDLEBAR#** Newmen Evolution SL 318.25, 760mm  
**GRIPS#** CUBE Race Grip 31mm, 1-Clamp  
**REAR DERAILLEUR#** Sram NX Eagle™, 12-Speed  
**SHIFTERS#** Sram SX Eagle™ Trigger, Single Click  
**BRAKE SYSTEM#** Magura MT Fifty, Hydr. Disc Brake (203/203)  
**CRANKSET#** CID E-Crank, 36T, 165mm  
**CASSETTE#** Sram PG-1210 Eagle™, 11-50T  
**CHAIN#** Sram SX Eagle™  
**RIMS#** CUBE EX30, 32H, Disc, Tubeless Ready  
**FRONT HUB#** Shimano HB-MT400-B, 15mm, Boost, Centerlock  
**REAR HUB#** Shimano FH-MT400-B, 12mm, Boost, Centerlock  
**TYRES#** Schwalbe Hans Dampf Kevlar, Addix Soft, Apex, Tubeless Easy, 2.60  
**SADDLE#** Natural Fit Venec  
**SEAT POST#** CUBE Dropper Post, Handlebar Lever, Internal Cable Routing, 31.6mm (16": 370x100mm, 18": 420x125mm, 20": 480x150mm)  
**SEATCLAMP#** CUBE Srewlock Semi Integrated, 34.9mm

**WEIGHT#** 3,3 kg

FULLSUSPENSION

# STEREO HYBRID 160 HPC SL 27.5

green'n'sharpgreen



Welcome to the all-new Stereo Hybrid 160 HPC SL – a bike that redefines what's possible. Building a world-beating enduro bike isn't easy. Building one that combines genuine enduro performance with the ease of use of Bosch's amazing drive system is even harder. Luckily, CUBE's years of experience at the Enduro World Series, as well as building class-leading Bosch e-bikes, helps make the job a tiny bit easier. Our engineering team was able to draw on their extensive hybrid, carbon and full suspension design experience to create something remarkable: a 160mm travel bike with carbon main frame, progressive suspension kinematics and an aggressive geometry designed specifically for 170mm forks and tough enduro courses, plus seamless Bosch power. The new CUBE Modular Battery System encloses the Bosch power unit in the down tube, hidden behind a shock-, moisture- and dust-proof cover that features a push button for access, as well as a hidden lock. It's not just neat, it also enables us to increase the battery's capacity for even greater range out in the mountains. Larger bearings, hidden cable routing, chain guide compatibility and space for a bottle cage mount are just some of the details that set this bike apart. As for the spec, it would have been easy to cut a few corners... but that's not the CUBE way. So you'll find a RockShox Deluxe Select+ shock and matching RockShox Lyrik Select fork up front, working together to deliver up to 170mm of boulder-swallowing travel. A remote dropper post opens up new line choices, while Sram's NX Eagle 12-speed transmission ensures you can ride every bit of the link stages. And Magura MT Fifty hydraulic disc brakes, combined with big-volume and super-grippy Schwalbe Hans Dampf tyres, give you all the power you need to control your speed on the timed stages. Combined with Bosch's fourth-generation drive unit, it's all the excuse you need to head out into the mountains and smash out some new personal bests. Are you ready? Because the Stereo Hybrid 160 HPC SL definitely is.

★ **337112** Cube Stereo Hybrid 160 HPC SL 625 27.5 green'n'sharpgreen 2020

**FRAME** #62 Monocoque Advanced Twin Mold Technology, Aluminum 6061 T6 Rear Triangle, Efficient Trail Control, FSP 4-Link, Agile Trail Geometry, Boost 148, Full Integrated Battery  
**SIZE** #6", 18", 20", 22"  
**FORK** #RockShox Lyrik Select Charger RC, 15x110mm, eMTB Approved, 170mm  
**SHOCK** #RockShox Deluxe Select+, 205x60mm, Trunnion Mount  
**SHOCK HARDWARE** #op: 54mm Trunnion Mount, Bottom: 22.2x8mm

**DRIVE UNIT** #Bosch Drive Unit Performance CX Generation 4 (75Nm) Cruise (250Watt)  
**BATTERY** #Bosch PowerTube 625  
**DISPLAY** #Bosch Purion  
**CHARGER** #Bosch 2A

**HEADSET** #SA Orbit Z 1.5E ZS, Top Zero-Stack 1 1/2" (OD 56mm), Bottom Zero-Stack 1 1/2" (OD 56mm)  
**STEM** #CUBE Performance Stem E-MTB, 31.8mm  
**HANDLEBAR** #Newmen Evolution SL 318.25, 760mm  
**GRIPS** #CUBE Race Grip 31mm, 1-Clamp  
**REAR DERAILLEUR** #Sram NX Eagle™, 12-Speed  
**SHIFTERS** #Sram SX Eagle™ Trigger, Single Click  
**BRAKE SYSTEM** #Magura MT Fifty, Hydr. Disc Brake (203/203)  
**CRANKSET** #CID E-Crank, 36T, 165mm  
**CASSETTE** #Sram PG-1210 Eagle™, 11-50T  
**CHAIN** #Sram SX Eagle™  
**RIMS** #CUBE EX30, 32H, Disc, Tubeless Ready  
**FRONT HUB** #Shimano HB-MT400-B, 15mm, Boost, Centerlock  
**REAR HUB** #Shimano FH-MT400-B, 12mm, Boost, Centerlock  
**TYRES** #Schwalbe Hans Dampf Kevlar, Addix Soft, Apex, Tubeless Easy, 2.60  
**SADDLE** #Natural Fit Venec  
**SEAT POST** #CUBE Dropper Post, Handlebar Lever, Internal Cable Routing, 31.6mm (16": 370x100mm, 18": 420x125mm, 20": 480x150mm)  
**SEATCLAMP** #CUBE Srewlock Semi Integrated, 34.9mm

📦 **WEIGHT** #3,3 kg

🔧 **SPARE PARTS**  
**8000** CUBE Headset Orbit Z 1.5E ZS  
**8528** CUBE BEARING\_pivot set-Ø15x87.4 (18-02089)  
**8529** CUBE AXLE\_pivot set-shock mount (18-02849)  
**8539** CUBE BEARING\_pivot set-Ø10x23,5  
**8540** CUBE BEARING\_pivot set-horst link  
**8651** CUBE HANGER\_mtb-x12-std-2020 (18-05516)

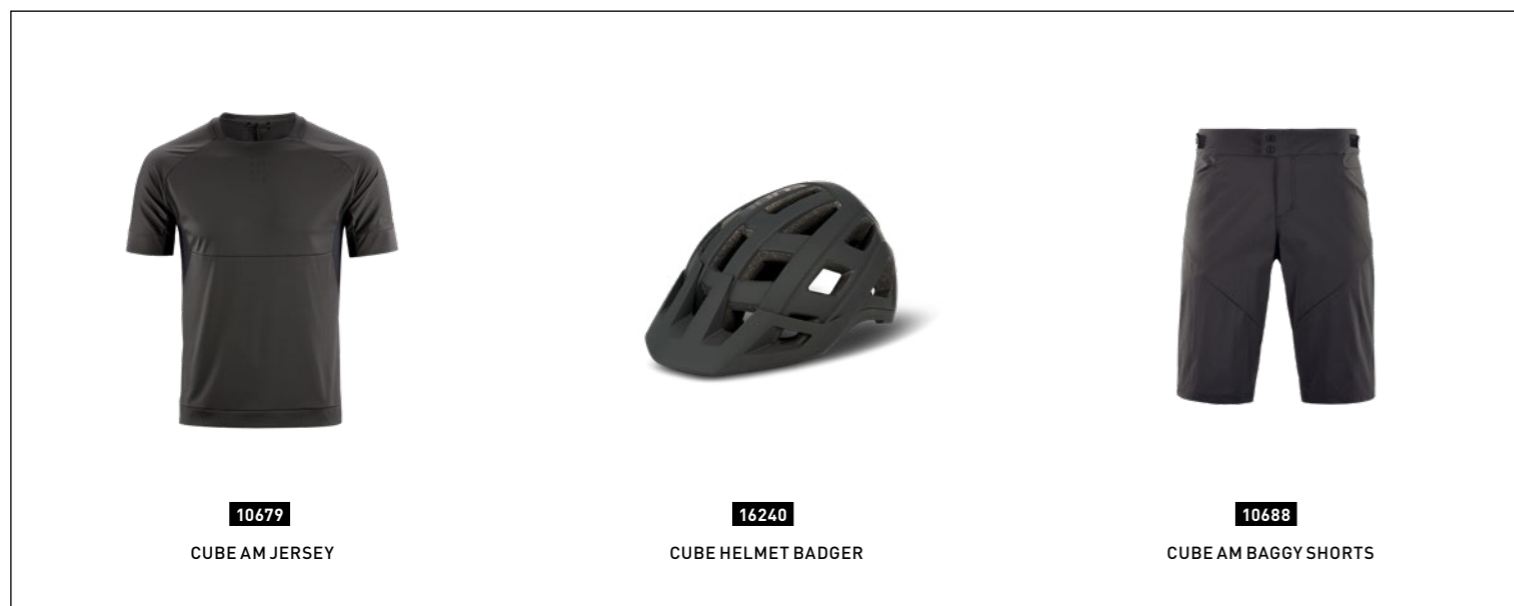

**10679**  
CUBE AM JERSEY



**16240**  
CUBE HELMET BADGER



**10688**  
CUBE AM BAGGY SHORTS

FULLSUSPENSION

# STEREO HYBRID 160 HPC SL 27.5

carbon'n'grey



Welcome to the all-new Stereo Hybrid 160 HPC SL – a bike that redefines what's possible. Building a world-beating enduro bike isn't easy. Building one that combines genuine enduro performance with the ease of use of Bosch's amazing drive system is even harder. Luckily, CUBE's years of experience at the Enduro World Series, as well as building class-leading Bosch e-bikes, helps make the job a tiny bit easier. Our engineering team was able to draw on their extensive hybrid, carbon and full suspension design experience to create something remarkable: a 160mm travel bike with carbon main frame, progressive suspension kinematics and an aggressive geometry designed specifically for 170mm forks and tough enduro courses, plus seamless Bosch power. The new CUBE Modular Battery System encloses the Bosch power unit in the down tube, hidden behind a shock-, moisture- and dust-proof cover that features a push button for access, as well as a hidden lock. It's not just neat, it also enables us to increase the battery's capacity for even greater range out in the mountains. Larger bearings, hidden cable routing, chain guide compatibility and space for a bottle cage mount are just some of the details that set this bike apart. As for the spec, it would have been easy to cut a few corners... but that's not the CUBE way. So you'll find a RockShox Deluxe Select+ shock and matching RockShox Lyrik Select fork up front, working together to deliver up to 170mm of boulder-swallowing travel. A remote dropper post opens up new line choices, while Sram's NX Eagle 12-speed transmission ensures you can ride every bit of the link stages. And Magura MT Fifty hydraulic disc brakes, combined with big-volume and super-grippy Schwalbe Hans Dampf tyres, give you all the power you need to control your speed on the timed stages. Combined with Bosch's fourth-generation drive unit, it's all the excuse you need to head out into the mountains and smash out some new personal bests. Are you ready? Because the Stereo Hybrid 160 HPC SL definitely is.

★ **337102** CUBE Stereo Hybrid 160 HPC SL 625 27.5 carbon'n'grey 2020

**FRAME#** 62 Monocoque Advanced Twin Mold Technology, Aluminum 6061 T6 Rear Triangle, Efficient Trail Control, FSP 4-Link, Agile Trail Geometry, Boost 148, Full Integrated Battery  
**SIZE#** 6", 18", 20", 22"  
**FORK#** RockShox Lyrik Select Charger RC, 15x110mm, eMTB Approved, 170mm  
**SHOCK#** RockShox Deluxe Select+, 205x60mm, Trunnion Mount  
**SHOCK HARDWARE#** Top: 54mm Trunnion Mount, Bottom: 22.2x8mm

**DRIVE UNIT#** Bosch Drive Unit Performance CX Generation 4 (75Nm) Cruise (250Watt)  
**BATTERY#** Bosch PowerTube 625  
**DISPLAY#** Bosch Purion  
**CHARGER#** Bosch 2A

**HEADSET#** SA Orbit Z 1.5E ZS, Top Zero-Stack 1 1/2" (OD 56mm), Bottom Zero-Stack 1 1/2" (OD 56mm)  
**STEM#** CUBE Performance Stem E-MTB, 31.8mm  
**HANDLEBAR#** Newmen Evolution SL 318.25, 760mm  
**GRIPS#** CUBE Race Grip 31mm, 1-Clamp  
**REAR DERAILLEUR#** Sram NX Eagle™, 12-Speed  
**SHIFTERS#** Sram SX Eagle™ Trigger, Single Click  
**BRAKE SYSTEM#** Magura MT Fifty, Hydr. Disc Brake (203/203)  
**CRANKSET#** CID E-Crank, 36T, 165mm  
**CASSETTE#** Sram PG-1210 Eagle™, 11-50T  
**CHAIN#** Sram SX Eagle™  
**RIMS#** CUBE EX30, 32H, Disc, Tubeless Ready  
**FRONT HUB#** Shimano HB-MT400-B, 15mm, Boost, Centerlock  
**REAR HUB#** Shimano FH-MT400-B, 12mm, Boost, Centerlock  
**TYRES#** Schwalbe Hans Dampf Kevlar, Addix Soft, Apex, Tubeless Easy, 2.60  
**SADDLE#** Natural Fit Venec  
**SEAT POST#** CUBE Dropper Post, Handlebar Lever, Internal Cable Routing, 31.6mm (16": 370x100mm, 18": 420x125mm, 20": 22": 480x150mm)  
**SEATCLAMP#** CUBE Srewlock Semi Integrated, 34.9mm

**SPARE PARTS#**  
**8000** CUBE Headset Orbit Z 1.5E ZS  
**8528** CUBE BEARING\_pivot set-Ø15x87.4 (18-02089)  
**8529** CUBE AXLE\_pivot set-shock mount (18-02849)  
**8539** CUBE BEARING\_pivot set-Ø10x23,5  
**8540** CUBE BEARING\_pivot set-horst link  
**8651** CUBE HANGER\_mtb-x12-std-2020 (18-05516)

**WEIGHT#** 3,3 kg



11098

CUBE FREERIDE CAP TEAM 93



10777

CUBE EDGE BAGGY SHORTS



10684

CUBE AM JERSEY



## FOR us #TrailHunters

Mountain bike hybrid versatility has a new name, and that name is Stereo Hybrid 140 HPC. Built around Bosch's new, fourth-generation drive system and drawing on our extensive experience of hybrid power, carbon frame construction and efficient suspension kinematics, it represents a new breed of all-mountain e-MTBs. Our engineering team developed a brand-new concept for this frame, building the CUBE Modular Battery System to hide the Bosch power unit completely inside the sleek carbon down tube. A tough cover provides protection and shock absorption for the battery, whilst push-button access and a hidden lock make it both easy to use and secure from unwelcome attention. Even better, the new system frees up enough space for the option of a higher capacity battery than before, which translates to extended range and longer days out in the mountains. The fourth-generation Bosch CX drive unit sits in its own housing, while the aluminium rear triangle features a Boost 148 axle for efficient power transfer, larger bearings for longer life and a linkage designed to fit a trunnion shock. Our All Mountain Geometry is specifically designed to work with the suspension kinematics and Bosch drive system, offering handling that only our fully integrated design is capable of doing – stable, confidence-inspiring and fun. And of course it's chain guide compatible, there's a bottle cage mount for carrying tools or water, and integrated cable routing ensures that gears carry on shifting smoothly with minimal maintenance. Because who wants to spend time fiddling with their bike, when another day in the mountains beckons? All Mountain versatility, redefined: that's the Stereo Hybrid HPC 140.



# STEREO HYBRID 140 HPC SLT 29

carbon 'n' silver



There's absolutely nothing in the world that our design team likes more than to be let loose on a bike with a brief to simply build the best. And here, in the new Stereo Hybrid HPC SLT, we have one of the results: the ultimate expression of all-mountain performance in a 29er Bosch e-bike, with absolutely no expense spared. With 140mm of travel at the front from the superbly plush RockShox Pike Ultimate fork and 140mm at the rear, courtesy of the equally smooth and progressive RockShox Deluxe Ultimate trunnion-mount shock, there's barely a mountain trail that can't be ridden on this bike. The light, strong and rigid Newman Advanced SL carbon wheelset, shod with grippy and comfortable Schwalbe Hans Dampf 2.6in tyres, transfers the fourth-generation Bosch CX drive unit's power – and your pedalling input – to the ground via Sram's incredible X01 Eagle AXS wireless 12-speed gears. Whatever the climb, however steep the challenge, this is a bike that's up for it. And, coming back down, you've the reassurance of the RockShox Reverb AXS dropper post, RaceFace cockpit components and super-powerful Magura MT Trail Carbon hydraulic disc brakes with oversized 203mm rotors for better cooling. But it isn't just about the components, because the Stereo Hybrid 140 HPC SLT also features our completely redesigned all-mountain e-bike chassis with carbon main frame, revised kinematics and tweaked Agile Trail Geometry for rock-solid handling in any situation. We're particularly proud of the Modular Battery System and its shock-absorbing, dust- and moisture-resistant cover with push-button release and hidden lock. It doesn't just hide the Bosch power unit away inside the sleek down tube, it also enabled our designers to fit a larger capacity battery for extended range – and leave room for a bottle cage mount. It's this kind of attention to detail that makes the CUBE difference, and means you can rely on your Stereo Hybrid 140 HPC SLT in the mountains. However tough the trail, it'll be there for you. Will you accept the challenge?

★ **336302** Cube Stereo Hybrid 140 HPC SLT 625 29 carbon 'n' silver 2020

**FRAME** #62 Monocoque Advanced Twin Mold Technology, Aluminum 6061 T6 Rear Triangle, Efficient Trail Control, FSP 4-Link, Agile Trail Geometry, Boost 148, Full Integrated Battery  
**SIZE** #6", 18", 20", 22"  
**FORK** #RockShox Pike Ultimate RC2, 15x110mm, Tapered, eMTB Approved, 140mm  
**SHOCK** #RockShox Deluxe Ultimate, 185x55mm, Trunnion Mount  
**SHOCK HARDWARE** #Top: 54mm Trunnion Mount, Bottom: 22.2x8mm

**DRIVE UNIT** #Bosch Drive Unit Performance CX Generation 4 (75Nm) Cruise (250Watt)  
**BATTERY** #Bosch PowerTube 625  
**DISPLAY** #Bosch Kiox  
**CHARGER** #Bosch 4A

**HEADSET** #SA Orbit Z 1.5E ZS, Top Zero-Stack 1 1/2" (OD 56mm), Bottom Zero-Stack 1 1/2" (OD 56mm)  
**STEM** #Race Face Turbine R 35  
**HANDLEBAR** #Race Face Next R 35 Carbon, 780mm  
**GRIPS** #CUBE Race Grip 31mm, 1-Clamp  
**REAR DERAILLEUR** #Sram X01 Eagle AXS™, 12-Speed  
**SHIFTERS** #Sram Eagle AXS™ Controllor  
**BRAKE SYSTEM** #Magura MT Trail Carbon, Hydr. Disc Brake (203/203)  
**CRANKSET** #\*thirteen TRSr Carbon Crank, 34T, 165mm  
**CASSETTE** #Sram XG-1299 Rainbow, 10-50T  
**CHAIN** #Sram PC-XX1 Eagle™ Rainbow  
**CHAIN GUIDE** #\*thirteen Plus e\*spec  
**WHEELSET** #Newman Advanced SL E.30, 28/28 Spokes, 15x110mm/12x148mm, Tubeless Ready  
**FRONT TIRE** #Schwalbe Hans Dampf, Addix Soft, Apex, Tubeless Easy, 2.60  
**REAR TIRE** #Schwalbe Hans Dampf, Addix Speedgrip, Apex, Tubeless Easy, 2.60  
**SADDLE** #Natural Fit Nuance SLT  
**SEAT POST** #RockShox Reverb AXS™ 31.6mm (16": 340x100mm; 18": 390x125mm; 20": 22": 440x150mm)  
**SEATCLAMP** #CUBE Srewlock Semi Integrated, 34.9mm

**SPARE PARTS**

8000	CUBE Headset Orbit Z 1.5E ZS
8528	CUBE BEARING_pivot set-Ø15x87.4 (18-02089)
8529	CUBE AXLE_pivot set-shock mount (18-02849)
8539	CUBE BEARING_pivot set-Ø10x23,5
8540	CUBE BEARING_pivot set-horst link
8651	CUBE HANGER_mtb-x12-std-2020 (18-05516)

**WEIGHT** #2,1 kg



93033

ACID PUMP RACE SHOCK 400 PED

14114

CUBE PEDALS SLASHER

93062

ACID OUTDOOR LED LIGHT HPA „RED“





FULLSUSPENSION

When you're riding the same bike as the pros, you know you're onto a winner – literally. And that's what you've got with the Stereo Hybrid 140 HPC Actionteam: the bike of choice of CUBE athletes, with no compromise. Based around our brand-new Stereo Hybrid 140 HPC 29er chassis, it features a no-holds-barred selection of premium components for ultimate performance. Making the most of our redesigned Agile Trail Geometry and progressive kinematics, the Fox Float DPX2 Factory shock – with trunnion mount – and Fox 36 Float Factory fork offer up to 150mm of smooth, controllable, rock-swallowing travel. Shimano's incredible wide-ranging 12-speed XT transmission works seamlessly with Bosch's fourth-generation CX drive unit to give you the power, torque and gear range to tackle any climb, while powerful XT hydraulic disc brakes with oversize 203mm rotors work with Schwalbe's grippy Super Gravity 2.6in Magic Mary and Hans Dampf tyres to anchor the Newmen rims and XT hubs on even the longest and steepest of descents. Fox's Transfer Factory internal dropper post, RaceFace cockpit components and a Natural Fit saddle put you firmly in control. And, of course, all of this peerless functionality is bolted to our latest all-mountain hybrid frameset with a host of new features. From the semi-integrated seat clamp and 1.5in straight-through steerer to the oversized bearings and chain stay protection with integrated cable routing, it's a masterpiece of elegant, practical design. But we're particularly proud of the new Modular Battery System, which houses the Bosch power unit inside the sleek down tube behind a shock-proof, dust- and moisture-resistant cover. This brand-new design enabled us to increase the battery's capacity, which means you can ride in the mountains for longer than ever before. It's a feature that our team riders will be making use of – and we're certain that you'll appreciate it, too.

★ **336252** Cube Stereo Hybrid 140 HPC Actionteam 625 29 actionteam 2020

**FRAME** #62 Monocoque Advanced Twin Mold Technology, Aluminum 6061 T6 Rear Triangle, Efficient Trail Control, FSP 4-Link, Agile Trail Geometry, Boost 148, Full Integrated Battery  
**SIZE** #6", 18", 20", 22"

**FORK** #Fox 36 Float Factory FIT4, 3-Position w/Low Speed Compression Adjust, Tapered, 15x110mm, E-Bike Tune, 170mm, Kashima Coated

**SHOCK** #Fox Float DPX2 Factory EVOL, Open(Adjustable)/Medium/Firm Mode, 185x55mm, Trunnion Mount, Kashima Coated

**SHOCK HARDWARE** #Top: 54mm Trunnion Mount, Bottom: 22.2x8mm

**DRIVE UNIT** #Bosch Drive Unit Performance CX Generation 4 (75Nm) Cruise (250Watt)

**BATTERY** #Bosch PowerTube 625

**DISPLAY** #Bosch Kiox

**CHARGER** #Bosch 4A

**HEADSET** #SA Orbit Z 1.5E ZS, Top Zero-Stack 1 1/2" (OD 56mm), Bottom Zero-Stack 1 1/2" (OD 56mm)

**STEM** #Race Face Turbine R 35

**HANDLEBAR** #Race Face Next R 35 Carbon, 800mm

**GRIPS** #CUBE Race Grip 31mm, 1-Clamp

**REAR DERAILLEUR** #Shimano XT RD-M8100-SGS, ShadowPlus, 12-Speed

**SHIFTERS** #Shimano XT SL-M8100-IR, Direct Attach

**BRAKE SYSTEM** #Shimano XT BR-M8120, Hydr. Disc Brake (203/203)

**CRANKSET** #thirteen Plus Crank, 34T, 165mm

**CASSETTE** #Shimano SLX CS-M7100, 10-51T

**CHAIN** #Shimano SLX CN-M7100

**CHAIN GUIDE** #thirteen Plus e\*spec

**RIMS** #Newmen Evolution SL E.35, 28H, Disc, Tubeless Ready

**FRONT HUB** #Shimano XT HB-M8110-B, 15QR, Boost, Centerlock

**REAR HUB** #Shimano XT FH-M8110-B, 12mm, Boost, Centerlock

**FRONT TIRE** #Schwalbe Magic Mary, Addix Soft, Super Gravity, Tubeless Easy, 2.60

**REAR TIRE** #Schwalbe Hans Dampf, Addix Speedgrip, Super Gravity, Tubeless Easy, 2.60

**SADDLE** #Natural Fit Venec

**SEAT POST** #Fox Transfer Factory 31.6mm, Kashima Coated (16": 359x100mm; 18": 409x125mm; 20", 22": 456x150mm)

**SEATCLAMP** #CUBE Srewlock Semi Integrated, 34.9mm

**WEIGHT** #3,6 kg

🔧 **SPARE PARTS#**

- 8000** CUBE Headset Orbit Z 1.5E ZS
- 8528** CUBE BEARING\_pivot set-Ø15x87.4 (18-02089)
- 8529** CUBE AXLE\_pivot set-shock mount (18-02849)
- 8539** CUBE BEARING\_pivot set-Ø10x23,5
- 8540** CUBE BEARING\_pivot set-horst link
- 8651** CUBE HANGER\_mtb-x12-std-2020 (18-05516)



16254

CUBE HELMET ROOK X ACTIONTEAM



10735

CUBE SOCKS HIGH CUT X ACTIONTEAM



10762

CUBE EDGE JERSEY X ACTIONTEAM

# STEREO HYBRID 140 HPC TM 29

grey'n'orange



How do you build a better mountain-taming e-MTB? Simple. Give the CUBE design team a blank sheet of paper and tell them not to compromise. And here's the result: the brand-new Stereo Hybrid 140 HPC TM. Completely redesigned from head tube to Boost 148 rear axle, it's the culmination of years of suspension, carbon and Bosch e-bike design experience. With fast-rolling 29er wheels, 150mm of front wheel travel from the Fox 36 Float Performance fork and 140mm at the rear courtesy of the Fox Float DPX2 Performance shock, it's got the cojones to take on any trail. Fulcrum E-Metal wheels and Schwalbe Super Gravity 2.6in Magic Mary and Hans Dampf tyres have the strength and grip to take on any mountain route, and the remote dropper post means you can roll through even the steepest chutes. Bosch's Kiox-controlled, fourth-generation CX drive unit delivers mile after mile of mountain-taming torque to the rear wheel via Sram's NX Eagle transmission, giving you the range you need to keep climbing when others have long since given up. And speaking of range, our new Modular Battery System – which encloses the Bosch power unit inside the sleek, carbon down tube – gave our engineers the room they needed to increase the battery's capacity for even longer days in the mountains. The shock-proof, dust- and moisture-resistant cover is easily accessed via a push button with hidden lock, and we even left room for a bottle cage mount. Larger bearings, chain guide compatibility and chain stay protection with integrated cable routing are just some of the other neat design touches that you'll appreciate. Although, to be honest, you'll probably be too busy enjoying the Agile Trail Geometry's dialled handling to worry about the finer details. Because, after all, that's what we're here for: to sweat the details, so that you can just enjoy the ride.

★ **336202** Cube Stereo Hybrid 140 HPC TM 625 29 grey'n'orange 2020

**FRAME#** 62 Monocoque Advanced Twin Mold Technology, Aluminum 6061 T6 Rear Triangle, Efficient Trail Control, FSP 4-Link, Agile Trail Geometry, Boost 148, Full Integrated Battery  
**SIZE#** 6", 18", 20", 22"  
**FORK#** Fox 36 Float GRIP, 3-Position w/Micro Adjust, Tapered, 15x110mm, E-Bike Tune, 150mm  
**SHOCK#** Fox Float DPX2 EVOL, 185x55mm, Open(Adjustable)/Medium/Firm Mode, Trunnion Mount  
**SHOCK HARDWARE#** Top: 54mm Trunnion Mount, Bottom: 22.2x8mm

**DRIVE UNIT#** Bosch Drive Unit Performance CX Generation 4 (75Nm) Cruise (250Watt)  
**BATTERY#** Bosch PowerTube 625  
**DISPLAY#** Bosch Kiox  
**CHARGER#** Bosch 4A

**HEADSET#** SA Orbit Z 1.5E Z5, Top Zero-Stack 1 1/2" (OD 56mm), Bottom Zero-Stack 1 1/2" (OD 56mm)  
**STEM#** CUBE Performance Stem E-MTB, 31.8mm  
**HANDLEBAR#** Newmen Evolution SL 318.25, 800mm  
**GRIPS#** CUBE Race Grip 31mm, 1-Clamp  
**REAR DERAILLEUR#** Sram NX Eagle™, 12-Speed  
**SHIFTERS#** Sram NX Eagle™ Trigger, Single Click  
**BRAKE SYSTEM#** Magura MT7, Hydr. Disc Brake (203/203)  
**CRANKSET#** \*thirteen Plus Crank, 34T, 165mm  
**CASSETTE#** Sram XG-1275, 10-50T  
**CHAIN#** Sram SX Eagle™  
**CHAIN GUIDE#** \*thirteen Plus e\*spec  
**WHEELSET#** Fulcrum E-Metal 700, 28/28 Spokes, 15x110mm/12x148mm, Tubeless Ready  
**FRONT TIRE#** Schwalbe Magic Mary, Addix Soft, Super Gravity, Tubeless Easy, 2.60  
**REAR TIRE#** Schwalbe Hans Dampf, Addix Speedgrip, Super Gravity, Tubeless Easy, 2.60  
**SADDLE#** Natural Fit Venec  
**SEAT POST#** CUBE Dropper Post, Handlebar Lever, Internal Cable Routing, 31.6mm (16": 370x100mm, 18": 420x125mm, 20": 22": 480x150mm)  
**SEATCLAMP#** CUBE Srewlock Semi Integrated, 34.9mm

**SPARE PARTS#**  
**8000** CUBE Headset Orbit Z 1.5E Z5  
**8528** CUBE BEARING\_pivot set-Ø15x87.4 (18-02089)  
**8529** CUBE AXLE\_pivot set-shock mount (18-02849)  
**8539** CUBE BEARING\_pivot set-Ø10x23,5  
**8540** CUBE BEARING\_pivot set-horst link  
**8651** CUBE HANGER\_mtb-x12-std-2020 (18-05516)

**WEIGHT#** 4,1 kg

FULLSUSPENSION





# STEREO HYBRID 140 HPC SL 29

red'n'black



When you've run out of excuses, when only the best all-mountain Bosch e-bike will do... that's when you're ready to move up to the new Stereo Hybrid 140 HPC SL. Representing a new benchmark in rugged, adaptable e-MTB performance, it's exactly the kind of bike you need to move your riding up to the next level. Component highlights include fast-rolling 29er wheels, a Shimano SLX and XT 12-speed transmission, and Shimano XT hydraulic disc brakes with large 203mm rotors front and rear for better brake performance on long, steep descents. But star of the show is the new frame. Using all their experience of building awesome trail-taming full suspension hybrids, our engineering team designed a brand-new chassis focussed around an elegant carbon main frame and an agile, stiff and responsive aluminium four-bar suspension assembly with trunnion shock and new, larger bearings for improved performance. A Fox Float DPS Performance shock and Fox 34 Rhythm fork work in perfect harmony to smooth out the trail, while a remote dropper post and the assured grip of Schwalbe's 2.6in Hans Dampf tyres – combined with our Agile Trail Geometry – open up even the most adventurous line choices. Our new Modular Battery System fully encloses the Bosch power unit inside the frame's sleek down tube, hidden under a two-piece battery cover with extra protection from dust, moisture and shock. Easily removable with a push button and hidden lock, it also means we've been able to increase the battery's capacity for even more range – and there's still room for a bottle cage mount. And of course, Bosch's superb fourth-generation CX drive unit serves up effortlessly smooth power with fingertip control from the Kiox Remote. For great days out in the mountains, all you need to add is you... and your spirit of adventure.

★ **336172** Cube Stereo Hybrid 140 HPC SL 625 29 red'n'black 2020

**FRAME** #62 Monocoque Advanced Twin Mold Technology, Aluminum 6061 T6 Rear Triangle, Efficient Trail Control, FSP 4-Link, Agile Trail Geometry, Boost 148, Full Integrated Battery  
**SIZE** #6", 18", 20", 22"  
**FORK** #Fox 34 Rhythm, 2-Position Sweep-Adjust GRIP Damper, 15x110mm, E-Bike Tune, 140mm  
**SHOCK** #Fox Float DPS EVOL, 185x55mm, Open/Medium/Firm Mode, Trunnion Mount  
**SHOCK HARDWARE** #Top: 54mm Trunnion Mount, Bottom: 22.2x8mm

**DRIVE UNIT** #Bosch Drive Unit Performance CX Generation 4 (75Nm) Cruise (250Watt)  
**BATTERY** #Bosch PowerTube 625  
**DISPLAY** #Bosch Kiox  
**CHARGER** #Bosch 4A

**HEADSET** #SA Orbit Z 1.5E ZS, Top Zero-Stack 1 1/2" (OD 56mm), Bottom Zero-Stack 1 1/2" (OD 56mm)  
**STEM** #CUBE Performance Stem E-MTB, 31.8mm  
**HANDLEBAR** #Newmen Evolution SL 318.25, 760mm  
**GRIPS** #CUBE Race Grip 31mm, 1-Clamp  
**REAR DERAILLEUR** #Shimano XT RD-M8100-SGS, ShadowPlus, 12-Speed  
**SHIFTERS** #Shimano SLX SL-M7100-I Direct Attach  
**BRAKE SYSTEM** #Shimano XT BR-M8120/M8100, Hydr. Disc Brake (203/203)  
**CRANKSET** #CID E-Crank, 34T, 165mm  
**CASSETTE** #Shimano SLX CS-M7100, 10-51T  
**CHAIN** #Shimano SLX CN-M7100  
**CHAIN GUIDE** #\*thirteen Plus e\*spec  
**RIMS** #CUBE EX30, 32H, Disc, Tubeless Ready  
**FRONT HUB** #Shimano HB-MT400-B, 15mm, Boost, Centerlock  
**REAR HUB** #Shimano FH-MT510-B, 12mm, Boost, Centerlock  
**FRONT TIRE** #Schwalbe Hans Dampf, Addix Soft, Apex, Tubeless Easy, 2.60  
**REAR TIRE** #Schwalbe Hans Dampf, Addix Speedgrip, Apex, Tubeless Easy, 2.60  
**SADDLE** #Natural Fit Venec  
**SEAT POST** #CUBE Dropper Post, Handlebar Lever, Internal Cable Routing, 31.6mm (16": 370x100mm, 18": 420x125mm, 20": 22": 480x150mm)  
**SEATCLAMP** #CUBE Srewlock Semi Integrated, 34.9mm

**SPARE PARTS**  
**8000** CUBE Headset Orbit Z 1.5E ZS  
**8528** CUBE BEARING\_pivot set-Ø15x87.4 (18-02089)  
**8529** CUBE AXLE\_pivot set-shock mount (18-02849)  
**8539** CUBE BEARING\_pivot set-Ø10x23,5  
**8540** CUBE BEARING\_pivot set-horst link  
**8651** CUBE HANGER\_mtb-x12-std-2020 (18-05516)

**WEIGHT** #3,5 kg



**11032**  
CUBE AM WS JERSEY

**10700**  
CUBE AM WS BAGGY SHORTS

**12100**  
CUBE BACKPACK EDGE TRAIL

# STEREO HYBRID 140 HPC SL 29

reefblue'n'yellow



40396  
CUBETOOL 20 IN 1

11606  
CUBE FUNCTIONAL BANDANA RACE

13851  
RFR POWER LIGHT 300 USB „WHITE“

When you've run out of excuses, when only the best all-mountain Bosch e-bike will do... that's when you're ready to move up to the new Stereo Hybrid 140 HPC SL. Representing a new benchmark in rugged, adaptable e-MTB performance, it's exactly the kind of bike you need to move your riding up to the next level. Component highlights include fast-rolling 29er wheels, a Shimano SLX and XT 12-speed transmission, and Shimano XT hydraulic disc brakes with large 203mm rotors front and rear for better brake performance on long, steep descents. But star of the show is the new frame. Using all their experience of building awesome trail-taming full suspension hybrids, our engineering team designed a brand-new chassis focussed around an elegant carbon main frame and an agile, stiff and responsive aluminium four-bar suspension assembly with trunnion shock and new, larger bearings for improved performance. A Fox Float DPS Performance shock and Fox 34 Rhythm fork work in perfect harmony to smooth out the trail, while a remote dropper post and the assured grip of Schwalbe's 2.6in Hans Dampf tyres - combined with our Agile Trail Geometry - open up even the most adventurous line choices. Our new Modular Battery System fully encloses the Bosch power unit inside the frame's sleek down tube, hidden under a two-piece battery cover with extra protection from dust, moisture and shock. Easily removable with a push button and hidden lock, it also means we've been able to increase the battery's capacity for even more range - and there's still room for a bottle cage mount. And of course, Bosch's superb fourth-generation CX drive unit serves up effortlessly smooth power with fingertip control from the Kiox Remote. For great days out in the mountains, all you need to add is you... and your spirit of adventure.

★ 336162 Cube Stereo Hybrid 140 HPC SL 625 29 reefblue'n'yellow 2020

**FRAME** #62 Monocoque Advanced Twin Mold Technology, Aluminum 6061 T6 Rear Triangle, Efficient Trail Control, FSP 4-Link, Agile Trail Geometry, Boost 148, Full Integrated Battery  
**SIZE** #6", 18", 20", 22"  
**FORK** #Fox 34 Rhythm, 2-Position Sweep-Adjust GRIP Damper, 15x110mm, E-Bike Tune, 140mm  
**SHOCK** #Fox Float DPS EVOL, 185x55mm, Open/Medium/Firm Mode, Trunnion Mount  
**SHOCK HARDWARE** #Top: 54mm Trunnion Mount, Bottom: 22.2x8mm

**DRIVE UNIT** #Bosch Drive Unit Performance CX Generation 4 (75Nm) Cruise (250Watt)  
**BATTERY** #Bosch PowerTube 625  
**DISPLAY** #Bosch Kiox  
**CHARGER** #Bosch 4A

**HEADSET** #SA Orbit Z 1.5E ZS, Top Zero-Stack 1 1/2" (OD 56mm), Bottom Zero-Stack 1 1/2" (OD 56mm)  
**STEM** #CUBE Performance Stem E-MTB, 31.8mm  
**HANDLEBAR** #Newmen Evolution SL 318.25, 760mm  
**GRIPS** #CUBE Race Grip 31mm, 1-Clamp  
**REAR DERAILLEUR** #Shimano XT RD-M8100-SGS, ShadowPlus, 12-Speed  
**SHIFTERS** #Shimano SLX SL-M7100-I Direct Attach  
**BRAKE SYSTEM** #Shimano XT BR-M8120/M8100, Hydr. Disc Brake (203/203)  
**CRANKSET** #CID E-Crank, 34T, 165mm  
**CASSETTE** #Shimano SLX CS-M7100, 10-51T  
**CHAIN** #Shimano SLX CN-M7100  
**CHAIN GUIDE** #\*thirteen Plus e\*spec  
**RIMS** #CUBE EX30, 32H, Disc, Tubeless Ready  
**FRONT HUB** #Shimano HB-MT400-B, 15mm, Boost, Centerlock  
**REAR HUB** #Shimano FH-MT510-B, 12mm, Boost, Centerlock  
**FRONT TIRE** #Schwalbe Hans Dampf, Addix Soft, Apex, Tubeless Easy, 2.60  
**REAR TIRE** #Schwalbe Hans Dampf, Addix Speedgrip, Apex, Tubeless Easy, 2.60  
**SADDLE** #Natural Fit Venec  
**SEAT POST** #CUBE Dropper Post, Handlebar Lever, Internal Cable Routing, 31.6mm (16": 370x100mm, 18": 420x125mm, 20": 22": 480x150mm)  
**SEATCLAMP** #CUBE Srewlock Semi Integrated, 34.9mm

**SPARE PARTS**  
**8000** CUBE Headset Orbit Z 1.5E ZS  
**8528** CUBE BEARING\_pivot set-Ø15x87.4 (18-02089)  
**8529** CUBE AXLE\_pivot set-shock mount (18-02849)  
**8539** CUBE BEARING\_pivot set-Ø10x23,5  
**8540** CUBE BEARING\_pivot set-horst link  
**8651** CUBE HANGER\_mtb-x12-std-2020 (18-05516)

**WEIGHT** #3,5 kg

FULLSUSPENSION



# STEREO HYBRID 140 HPC SL 29

iridium'n'green



When you've run out of excuses, when only the best all-mountain Bosch e-bike will do... that's when you're ready to move up to the new Stereo Hybrid 140 HPC SL. Representing a new benchmark in rugged, adaptable e-MTB performance, it's exactly the kind of bike you need to move your riding up to the next level. Component highlights include fast-rolling 29er wheels, a Shimano SLX and XT 12-speed transmission, and Shimano XT hydraulic disc brakes with large 203mm rotors front and rear for better brake performance on long, steep descents. But star of the show is the new frame. Using all their experience of building awesome trail-taming full suspension hybrids, our engineering team designed a brand-new chassis focussed around an elegant carbon main frame and an agile, stiff and responsive aluminium four-bar suspension assembly with trunnion shock and new, larger bearings for improved performance. A Fox Float DPS Performance shock and Fox 34 Rhythm fork work in perfect harmony to smooth out the trail, while a remote dropper post and the assured grip of Schwalbe's 2.6in Hans Dampf tyres – combined with our Agile Trail Geometry – open up even the most adventurous line choices. Our new Modular Battery System fully encloses the Bosch power unit inside the frame's sleek down tube, hidden under a two-piece battery cover with extra protection from dust, moisture and shock. Easily removable with a push button and hidden lock, it also means we've been able to increase the battery's capacity for even more range – and there's still room for a bottle cage mount. And of course, Bosch's superb fourth-generation CX drive unit serves up effortlessly smooth power with fingertip control from the Kiox Remote. For great days out in the mountains, all you need to add is you... and your spirit of adventure.

★ **336152** Cube Stereo Hybrid 140 HPC SL 625 29 iridium'n'green 2020

**FRAME** #62 Monocoque Advanced Twin Mold Technology, Aluminum 6061 T6 Rear Triangle, Efficient Trail Control, FSP 4-Link, Agile Trail Geometry, Boost 148, Full Integrated Battery  
**SIZE** #6", 18", 20", 22"  
**FORK** #Fox 34 Rhythm, 2-Position Sweep-Adjust GRIP Damper, 15x110mm, E-Bike Tune, 140mm  
**SHOCK** #Fox Float DPS EVOL, 185x55mm, Open/Medium/Firm Mode, Trunnion Mount  
**SHOCK HARDWARE** #op: 54mm Trunnion Mount, Bottom: 22.2x8mm

**DRIVE UNIT** #Bosch Drive Unit Performance CX Generation 4 (75Nm) Cruise (250Watt)  
**BATTERY** #Bosch PowerTube 625  
**DISPLAY** #Bosch Kiox  
**CHARGER** #Bosch 4A

**HEADSET** #SA Orbit Z 1.5E ZS, Top Zero-Stack 1 1/2" (OD 56mm), Bottom Zero-Stack 1 1/2" (OD 56mm)  
**STEM** #CUBE Performance Stem E-MTB, 31.8mm  
**HANDLEBAR** #Newmen Evolution SL 318.25, 760mm  
**GRIPS** #CUBE Race Grip 31mm, 1-Clamp  
**REAR DERAILLEUR** #Shimano XT RD-M8100-SGS, ShadowPlus, 12-Speed  
**SHIFTERS** #Shimano SLX SL-M7100-I Direct Attach  
**BRAKE SYSTEM** #Shimano XT BR-M8120/M8100, Hydr. Disc Brake (203/203)  
**CRANKSET** #CID E-Crank, 34T, 165mm  
**CASSETTE** #Shimano SLX CS-M7100, 10-51T  
**CHAIN** #Shimano SLX CN-M7100  
**CHAIN GUIDE** #\*thirteen Plus e\*spec  
**RIMS** #CUBE EX30, 32H, Disc, Tubeless Ready  
**FRONT HUB** #Shimano HB-MT400-B, 15mm, Boost, Centerlock  
**REAR HUB** #Shimano FH-MT510-B, 12mm, Boost, Centerlock  
**FRONT TIRE** #Schwalbe Hans Dampf, Addix Soft, Apex, Tubeless Easy, 2.60  
**REAR TIRE** #Schwalbe Hans Dampf, Addix Speedgrip, Apex, Tubeless Easy, 2.60  
**SADDLE** #Natural Fit Venec  
**SEAT POST** #CUBE Dropper Post, Handlebar Lever, Internal Cable Routing, 31.6mm (16": 370x100mm, 18": 420x125mm, 20": 22": 480x150mm)  
**SEATCLAMP** #CUBE Srewlock Semi Integrated, 34.9mm

**SPARE PARTS**  
**8000** CUBE Headset Orbit Z 1.5E ZS  
**8528** CUBE BEARING\_pivot set-Ø15x87.4 (18-02089)  
**8529** CUBE AXLE\_pivot set-shock mount (18-02849)  
**8539** CUBE BEARING\_pivot set-Ø10x23,5  
**8540** CUBE BEARING\_pivot set-horst link  
**8651** CUBE HANGER\_mtb-x12-std-2020 (18-05516)

**WEIGHT** #3,5 kg

FULLSUSPENSION



# STEREO HYBRID 140 HPC RACE 29

petrol 'n' red



There are times when more really is more. More travel, more versatility, more possibilities. Completely redesigned for 2020, the Stereo Hybrid HPC 140 Race takes everything we've learnt about building mountain-taming e-bikes, and re-packages it into a 29er Bosch e-bike that's even more capable. You'd probably guess from the RockShox Deluxe Select trunnion-mount shock and RockShox 35 Gold fork that we're serious about its suspension capabilities, and you'd be right. Larger, more durable bearings and a Boost 148 rear end help make this our best-performing all-mountain e-bike to date, helped along by our Agile Trail Geometry and Efficient Trail Control kinematics. But that's just part of the story. The all-new, full carbon front triangle is full of neat touches like a semi-integrated seat clamp, integrated cable routing and one-screw drive unit cover. But star of the show is our new Modular Battery System, which houses the Bosch power unit securely completely within the oversized down tube, protected from the elements with a shock-absorbing cover. This new system isn't just incredibly easy to use – with a push-button release and hidden lock – but also enabled our engineers to create enough space for an optional larger battery, for extended range. And there's still room for a bottle cage mount, too. Sram's trend-setting SX Eagle 12-speed drivetrain helps transfer the fourth-generation Bosch CX drive unit's power to the rear wheel, while powerful Shimano hydraulic disc brakes – with an oversized 203mm rotor up front – work with Schwalbe's comfy, super-grippy 2.6in Nobby Nic tyres to give you all the control you need. And, because a bike like this is going to inspire you to do more, we even fitted a remote dropper post – so you can explore new lines. It all adds up to a compelling reason to get out into the mountains and ride. Will you rise to the challenge?

- ★ **336122** Cube Stereo Hybrid 140 HPC Race 625 29 petrol 'n' red 2020
- ★ **336121** Cube Stereo Hybrid 140 HPC Race 500 29 petrol 'n' red 2020

**FRAME** #62 Monocoque Advanced Twin Mold Technology, Aluminum 6061 T6 Rear Triangle, Efficient Trail Control, FSP 4-Link, Agile Trail Geometry, Boost 148, Full Integrated Battery  
**SIZE** #6", 18", 20", 22"  
**FORK** #RockShox 35 Gold, Tapered, 15x110mm, eMTB Approved, 140mm  
**SHOCK** #RockShox Deluxe Select, 185x55mm, Rebound Adjust, Trunnion Mount  
**SHOCK HARDWARE** #top: 54mm Trunnion Mount, Bottom: 22.2x8mm

**DRIVE UNIT** #Bosch Drive Unit Performance CX Generation 4 (75Nm) Cruise (250Watt)  
**BATTERY** #Bosch PowerTube 625  
**DISPLAY** #Bosch Kiox  
**CHARGER** #Bosch 2A

**HEADSET** #SA Orbit Z 1.5B ZS, Top Zero-Stack 1 1/2" [OD 56mm], Bottom Zero-Stack 1 1/2" [OD 56mm]  
**STEM** #CUBE Performance Stem E-MTB, 31.8mm  
**HANDLEBAR** #Newmen Evolution SL 318.25, 760mm  
**GRIPS** #CUBE Race Grip 31mm, 1-Clamp  
**REAR DERAILLEUR** #Sram NX Eagle™, 12-Speed  
**SHIFTERS** #Sram SX Eagle™ Trigger, Single Click  
**BRAKE SYSTEM** #Shimano BR-MT420, Hydr. Disc Brake (203/180)  
**CRANKSET** #CID E-Crank, 34T, 165mm  
**CASSETTE** #Sram PG-1210 Eagle™, 11-50T  
**CHAIN** #Sram SX Eagle™  
**RIMS** #CUBE EX30, 32H, Disc, Tubeless Ready  
**FRONT HUB** #Shimano HB-MT400-B, 15mm, Boost, Centerlock  
**REAR HUB** #Shimano FH-MT400-B, 12mm, Boost, Centerlock  
**TYRES** #Schwalbe Nobby Nic, PerfL, 2.60  
**SADDLE** #Natural Fit Venec Lite  
**SEAT POST** #CUBE Dropper Post, Handlebar Lever, Internal Cable Routing, 31.6mm [16": 361x100mm; 18": 403x120mm; 20": 425x130mm]  
**SEATCLAMP** #CUBE Srewlock Semi Integrated, 34.9mm

- SPARE PARTS**
- 8000** CUBE Headset Orbit Z 1.5E ZS
  - 8528** CUBE BEARING\_pivot set-Ø15x87.4 (18-02089)
  - 8529** CUBE AXLE\_pivot set-shock mount (18-02849)
  - 8539** CUBE BEARING\_pivot set-Ø10x23,5
  - 8540** CUBE BEARING\_pivot set-horst link
  - 8651** CUBE HANGER\_mtb-x12-std-2020 (18-05516)

**WEIGHT** #3.7 kg



**17085**  
CUBE SHOES ATX LYNX PRO



**10776**  
CUBE EDGE JERSEY



**10777**  
CUBE EDGE BAGGY SHORTS

FULLSUSPENSION

# STEREO HYBRID 140 HPC RACE 29

green'n'sharpgreen



There are times when more really is more. More travel, more versatility, more possibilities. Completely redesigned for 2020, the Stereo Hybrid HPC 140 Race takes everything we've learnt about building mountain-taming e-bikes, and re-packages it into a 29er Bosch e-bike that's even more capable. You'd probably guess from the RockShox Deluxe Select trunnion-mount shock and RockShox 35 Gold fork that we're serious about its suspension capabilities, and you'd be right. Larger, more durable bearings and a Boost 148 rear end help make this our best-performing all-mountain e-bike to date, helped along by our Agile Trail Geometry and Efficient Trail Control kinematics. But that's just part of the story. The all-new, full carbon front triangle is full of neat touches like a semi-integrated seat clamp, integrated cable routing and one-screw drive unit cover. But star of the show is our new Modular Battery System, which houses the Bosch power unit securely completely within the oversized down tube, protected from the elements with a shock-absorbing cover. This new system isn't just incredibly easy to use – with a push-button release and hidden lock – but also enabled our engineers to create enough space for an optional larger battery, for extended range. And there's still room for a bottle cage mount, too. Sram's trend-setting SX Eagle 12-speed drivetrain helps transfer the fourth-generation Bosch CX drive unit's power to the rear wheel, while powerful Shimano hydraulic disc brakes – with an oversized 203mm rotor up front – work with Schwalbe's comfy, super-grippy 2.6in Nobby Nic tyres to give you all the control you need. And, because a bike like this is going to inspire you to do more, we even fitted a remote dropper post – so you can explore new lines. It all adds up to a compelling reason to get out into the mountains and ride. Will you rise to the challenge?

- ★ **336112** Cube Stereo Hybrid 140 HPC Race 625 29 green'n'sharpgreen 2020
- 336111** Cube Stereo Hybrid 140 HPC Race 500 29 green'n'sharpgreen 2020

**FRAME** #62 Monocoque Advanced Twin Mold Technology, Aluminum 6061 T6 Rear Triangle, Efficient Trail Control, FSP 4-Link, Agile Trail Geometry, Boost 148, Full Integrated Battery  
**SIZE** #6", 18", 20", 22"  
**FORK** #RockShox 35 Gold, Tapered, 15x110mm, eMTB Approved, 140mm  
**SHOCK** #RockShox Deluxe Select, 185x55mm, Rebound Adjust, Trunnion Mount  
**SHOCK HARDWARE** #top: 54mm Trunnion Mount, Bottom: 22.2x8mm

**DRIVE UNIT** #Bosch Drive Unit Performance CX Generation 4 (75Nm) Cruise (250Watt)  
**BATTERY** #Bosch PowerTube 625  
**DISPLAY** #Bosch Kiox  
**CHARGER** #Bosch 2A

**HEADSET** #SA Orbit Z 1.5B ZS, Top Zero-Stack 1 1/2" (OD 56mm), Bottom Zero-Stack 1 1/2" (OD 56mm)  
**STEM** #CUBE Performance Stem E-MTB, 31.8mm  
**HANDLEBAR** #Newmen Evolution SL 318.25, 760mm  
**GRIPS** #CUBE Race Grip 31mm, 1-Clamp  
**REAR DERAILLEUR** #Sram NX Eagle™, 12-Speed  
**SHIFTERS** #Sram SX Eagle™ Trigger, Single Click  
**BRAKE SYSTEM** #Shimano BR-MT420, Hydr. Disc Brake (203/180)  
**CRANKSET** #CID E-Crank, 34T, 165mm  
**CASSETTE** #Sram PG-1210 Eagle™, 11-50T  
**CHAIN** #Sram SX Eagle™  
**RIMS** #CUBE EX30, 32H, Disc, Tubeless Ready  
**FRONT HUB** #Shimano HB-MT400-B, 15mm, Boost, Centerlock  
**REAR HUB** #Shimano FH-MT400-B, 12mm, Boost, Centerlock  
**TYRES** #Schwalbe Nobby Nic, PerfL, 2.60  
**SADDLE** #Natural Fit Venec Lite  
**SEAT POST** #CUBE Dropper Post, Handlebar Lever, Internal Cable Routing, 31.6mm (16": 361x100mm; 18": 403x120mm; 20": 425x130mm)  
**SEATCLAMP** #CUBE Srewlock Semi Integrated, 34.9mm

**WEIGHT** #3.7 kg

- SPARE PARTS**
- 8000** CUBE Headset Orbit Z 1.5E ZS
  - 8528** CUBE BEARING\_pivot set-Ø15x87.4 (18-02089)
  - 8529** CUBE AXLE\_pivot set-shock mount (18-02849)
  - 8539** CUBE BEARING\_pivot set-Ø10x23,5
  - 8540** CUBE BEARING\_pivot set-horst link
  - 8651** CUBE HANGER\_mtb-x12-std-2020 (18-05516)

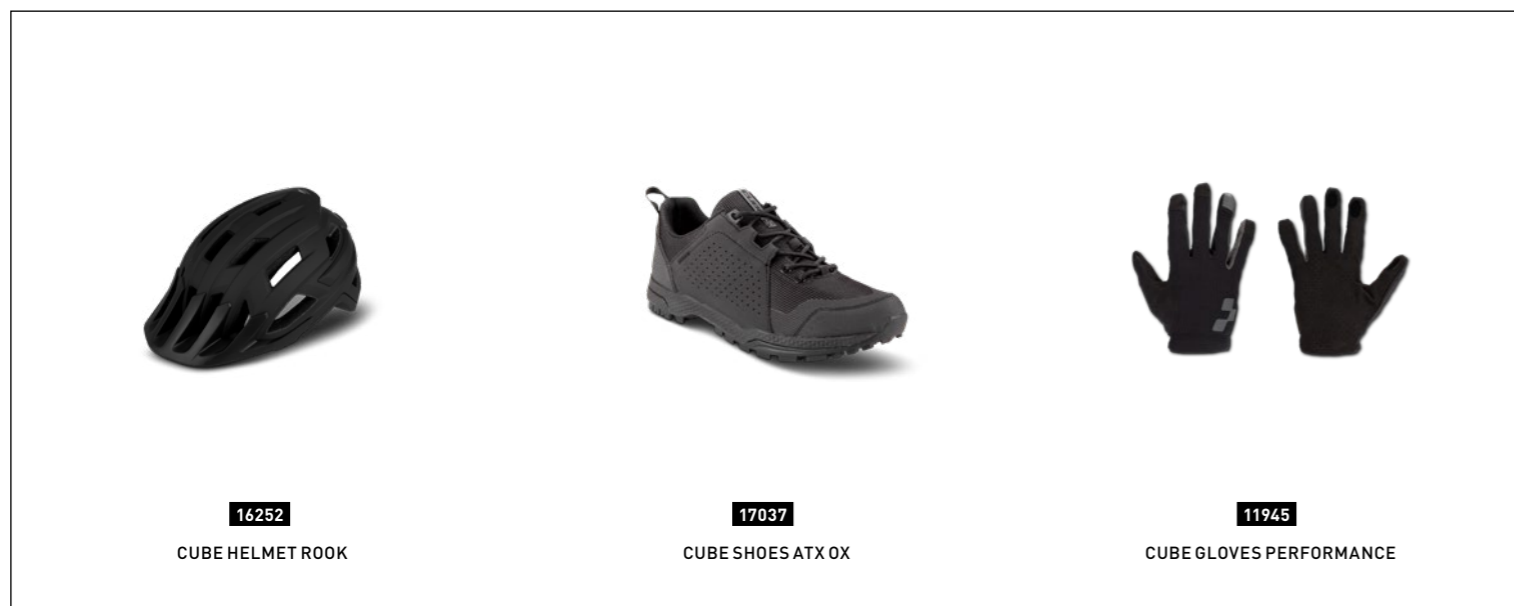

**16252**  
CUBE HELMET ROK

**17037**  
CUBE SHOES ATX OX

**11945**  
CUBE GLOVES PERFORMANCE

# STEREO HYBRID 140 HPC RACE 29

black'n'blue



There are times when more really is more. More travel, more versatility, more possibilities. Completely redesigned for 2020, the Stereo Hybrid HPC 140 Race takes everything we've learnt about building mountain-taming e-bikes, and re-packages it into a 29er Bosch e-bike that's even more capable. You'd probably guess from the RockShox Deluxe Select trunnion-mount shock and RockShox 35 Gold fork that we're serious about its suspension capabilities, and you'd be right. Larger, more durable bearings and a Boost 148 rear end help make this our best-performing all-mountain e-bike to date, helped along by our Agile Trail Geometry and Efficient Trail Control kinematics. But that's just part of the story. The all-new, full carbon front triangle is full of neat touches like a semi-integrated seat clamp, integrated cable routing and one-screw drive unit cover. But star of the show is our new Modular Battery System, which houses the Bosch power unit securely completely within the oversized down tube, protected from the elements with a shock-absorbing cover. This new system isn't just incredibly easy to use – with a push-button release and hidden lock – but also enabled our engineers to create enough space for an optional larger battery, for extended range. And there's still room for a bottle cage mount, too. Sram's trend-setting SX Eagle 12-speed drivetrain helps transfer the fourth-generation Bosch CX drive unit's power to the rear wheel, while powerful Shimano hydraulic disc brakes – with an oversized 203mm rotor up front – work with Schwalbe's comfy, super-grippy 2.6in Nobby Nic tyres to give you all the control you need. And, because a bike like this is going to inspire you to do more, we even fitted a remote dropper post – so you can explore new lines. It all adds up to a compelling reason to get out into the mountains and ride. Will you rise to the challenge?

- ★ **336102** Cube Stereo Hybrid 140 HPC Race 625 29 black'n'blue 2020
- ★ **336101** Cube Stereo Hybrid 140 HPC Race 500 29 black'n'blue 2020

**FRAME** #62 Monocoque Advanced Twin Mold Technology, Aluminum 6061 T6 Rear Triangle, Efficient Trail Control, FSP 4-Link, Agile Trail Geometry, Boost 148, Full Integrated Battery  
**SIZE** #6", 18", 20", 22"  
**FORK** #RockShox 35 Gold, Tapered, 15x110mm, eMTB Approved, 140mm  
**SHOCK** #RockShox Deluxe Select, 185x55mm, Rebound Adjust, Trunnion Mount  
**SHOCK HARDWARE** #top: 54mm Trunnion Mount, Bottom: 22.2x8mm

**DRIVE UNIT** #Bosch Drive Unit Performance CX Generation 4 (75Nm) Cruise (250Watt)  
**BATTERY** #Bosch PowerTube 625  
**DISPLAY** #Bosch Kiox  
**CHARGER** #Bosch 2A

**HEADSET** #SA Orbit Z 1.5B ZS, Top Zero-Stack 1 1/2" (OD 56mm), Bottom Zero-Stack 1 1/2" (OD 56mm)  
**STEM** #CUBE Performance Stem E-MTB, 31.8mm  
**HANDLEBAR** #Newmen Evolution SL 318.25, 760mm  
**GRIPS** #CUBE Race Grip 31mm, 1-Clamp  
**REAR DERAILLEUR** #Sram NX Eagle™, 12-Speed  
**SHIFTERS** #Sram SX Eagle™ Trigger, Single Click  
**BRAKE SYSTEM** #Shimano BR-MT420, Hydr. Disc Brake (203/180)  
**CRANKSET** #ACID E-Crank, 34T, 165mm  
**CASSETTE** #Sram PG-1210 Eagle™, 11-50T  
**CHAIN** #Sram SX Eagle™  
**RIMS** #CUBE EX30, 32H, Disc, Tubeless Ready  
**FRONT HUB** #Shimano HB-MT400-B, 15mm, Boost, Centerlock  
**REAR HUB** #Shimano FH-MT400-B, 12mm, Boost, Centerlock  
**TYRES** #Schwalbe Nobby Nic, PerfL, 2.60  
**SADDLE** #Natural Fit Venec Lite  
**SEAT POST** #CUBE Dropper Post, Handlebar Lever, Internal Cable Routing, 31.6mm (16": 361x100mm; 18": 403x120mm; 20": 425x130mm)  
**SEATCLAMP** #CUBE Srewlock Semi Integrated, 34.9mm

- SPARE PARTS**
- 8000** CUBE Headset Orbit Z 1.5E ZS
  - 8528** CUBE BEARING\_pivot set-Ø15x87.4 (18-02089)
  - 8529** CUBE AXLE\_pivot set-shock mount (18-02849)
  - 8539** CUBE BEARING\_pivot set-Ø10x23,5
  - 8540** CUBE BEARING\_pivot set-horst link
  - 8651** CUBE HANGER\_mtb-x12-std-2020 (18-05516)

**WEIGHT** #3.7 kg



**11440**  
CUBE JERSEY ACTIVE



**11408**  
CUBE BAGGY SHORTS ACTIVE



**16169**  
CUBE HELMET ROOK

FULLSUSPENSION

---

## FOR us #Explorers

---

When you've got a successful formula, it's very tempting to stick with it. The versatile Stereo Hybrid 120 was widely admired by riders and the cycling press alike, but the launch of Bosch's fourth-generation drive system gave us the opportunity to make a legend even better. Based around our new Modular Battery System, the new frame is even sleeker, more practical and better handling. Hidden behind a push-button battery cover with integrated lock, the Bosch power unit integrates so neatly into the frame that it's hard to believe it's even a hybrid. It's not just about looks, though, because the new design also enabled our engineers to free up enough room for the option of a bigger capacity battery for extended range. It's all wrapped up in our Comfort Geometry – making the most of our refined four-bar suspension design to ensure a plush, confidence-inspiring ride, wherever your curiosity leads you – and backed up by the knowledge that, like all our bikes, it's passed our strict in-house safety testing with flying colours. For added versatility, we also made it easy to add a luggage carrier, mudguards and even a kickstand – so you can set up your bike exactly the way you want – commute, trail or tour. The new Stereo Hybrid 120 is your passport to riding freedom. Where will it take you next?



# STEREO HYBRID 120 SL 29

blue 'n' yellow



FULLSUSPENSION

You've earned it: a Bosch e-MTB without compromise. The brand-new Stereo Hybrid 120 SL is a worthy range-topper for our award-winning Stereo Hybrid 120 range – sleek, comfortable, efficient and boasting the very best components to help you ride further, higher and faster than before. From the huge range of Shimano's XT gears to the superb power and controllability of the four-piston XT hydraulic discs with oversize 203mm rotors, there's no compromise in tactility or function. Even better, our new Stereo Hybrid 120 chassis enabled our engineers to fine-tune this legendary bike's performance even further. The Modular Battery System completely encloses the Bosch power unit in the gravity cast down tube for sleek looks, protection against the elements and enough room for a bigger battery with even more range than before. Meanwhile Bosch's fourth-generation CX drive unit and Kiox controller transfer power efficiently and quietly to the rear wheel, helped by the rigidity of the Boost 148 rear end. The trunnion mount Fox Float DPS Performance rear shock and Fox 34 Rhythm fork work in perfect harmony, thanks partly to the experience and engineering expertise of our design team and their finely tuned, four-bar suspension system and Agile Comfort Geometry. With a remote dropper post, grippy 2.6in Schwalbe tyres and wide Newmen Evolution handlebar, you'll always be in full control of the situation, wherever you happen to find yourself. We sweated the details – including making it kickstand-ready – so that the only sweat you'll expend is working out where to go next...

★ **335212** Cube Stereo Hybrid 120 SL 625 29 blue 'n' yellow 2020

**FRAME** Aluminum Superlite, Gravity Casting Technology, Efficient Comfort Control, FSP 4-Link, Agile Comfort Geometry, Boost 148, Full Integrated Battery, Kickstand/Fender/Carrier Mounting Points  
**SIZE** #6", 18", 20", 22"  
**FORK** #Fox 34 Rhythm, 2-Position Sweep-Adjust GRIP Damper, Tapered, 15x110mm, E-Bike Tune, 120mm  
**SHOCK** #Fox Float DPS EVOL, 185x55mm, Open/Medium/Firm Mode, Trunnion Mount  
**SHOCK HARDWARE** #Top: 54mm Trunnion Mount, Bottom: 30x8mm

**DRIVE UNIT** #Bosch Drive Unit Performance CX Generation 4 (75Nm) Cruise (250Watt)  
**BATTERY** #Bosch PowerTube 625  
**DISPLAY** #Bosch Kiox  
**CHARGER** #Bosch 4A

**HEADSET** #SA Orbit Z 1.5E ZS, Top Zero-Stack 1 1/2" (OD 56mm), Bottom Zero-Stack 1 1/2" (OD 56mm)  
**STEM** #CUBE Performance Stem E-MTB, 31.8mm  
**HANDLEBAR** #Newmen Evolution SL 318.25, 760mm  
**GRIPS** #Natural Fit All Terrain  
**REAR DERAILLEUR** #Shimano XT RD-M8100-SGS, ShadowPlus, 12-Speed  
**SHIFTERS** #Shimano XT SL-M8100-IR, Direct Attach  
**BRAKE SYSTEM** #Shimano XT BR-M8120, Hydr. Disc Brake (203/203)  
**CRANKSET** #thirteen Plus Crank, 38T, 170mm  
**CASSETTE** #Shimano XT CS-M8100, 10-51T  
**CHAIN** #Shimano XT CN-M8100  
**RIMS** #CUBE EX30, 32H, Disc, Tubeless Ready  
**FRONT HUB** #Shimano HB-MT400-B, 15mm, Boost, Centerlock  
**REAR HUB** #Shimano FH-MT510-B, 12mm, Boost, Centerlock  
**TYRES** #Schwalbe Smart Sam, Performance, Kevlar, 2.60  
**PEDALS** #CUBE PP MTB  
**SADDLE** #Natural Fit Sequence+  
**SEAT POST** #CUBE Dropper Post, Handlebar Lever, Internal Cable Routing, 30.9mm (16": 361x100mm; 18": 403x120mm; 20": 425x130mm)  
**SEATCLAMP** #CUBE Varioclose Semi Integrated, 34.9mm

**SPARE PARTS**  
**8000** CUBE Headset Orbit Z 1.5E ZS  
**8528** CUBE BEARING\_pivot set-Ø15x87.4 (18-02089)  
**8529** CUBE AXLE\_pivot set-shock mount (18-02849)  
**8539** CUBE BEARING\_pivot set-Ø10x23,5  
**8540** CUBE BEARING\_pivot set-horst link  
**8651** CUBE HANGER\_mtb-x12-std-2020 (18-05516)

**WEIGHT** #4,3 kg

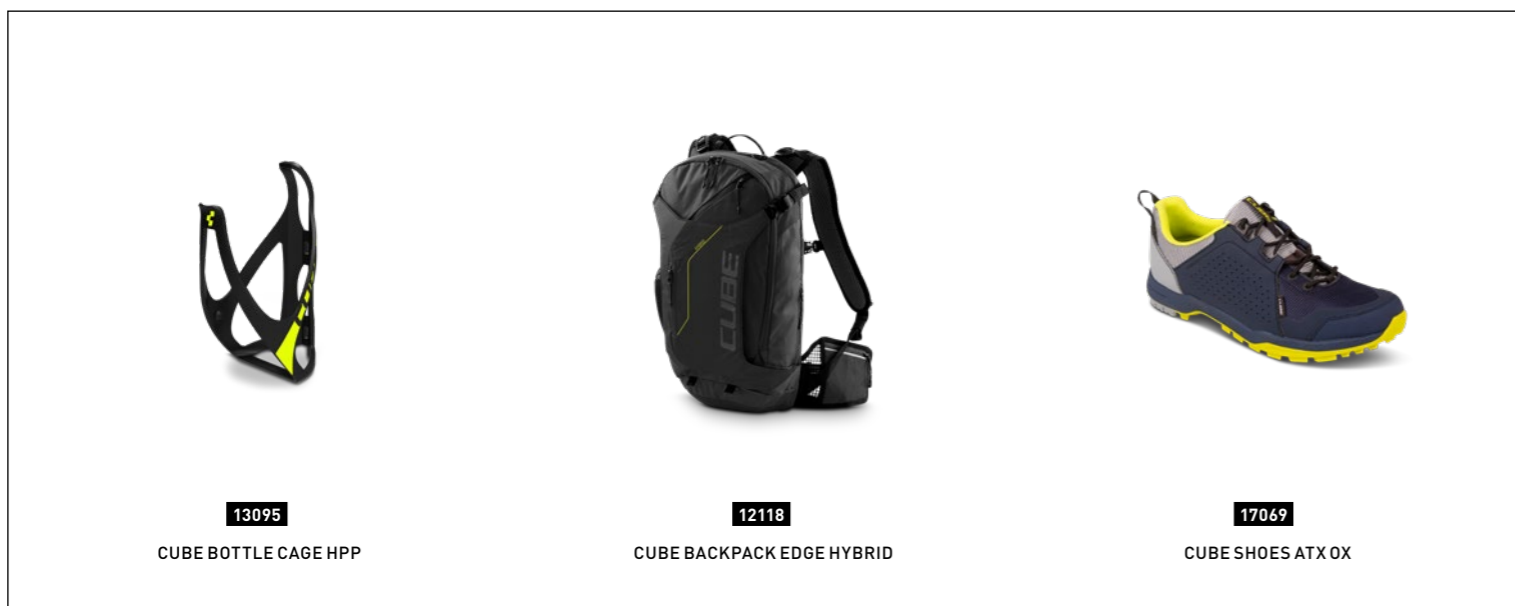

**13095**  
CUBE BOTTLE CAGE HPP

**12118**  
CUBE BACKPACK EDGE HYBRID

**17069**  
CUBE SHOES ATX OX



# STEREO HYBRID 120 SL 29

black'n'grey



You've earned it: a Bosch e-MTB without compromise. The brand-new Stereo Hybrid 120 SL is a worthy range-topper for our award-winning Stereo Hybrid 120 range – sleek, comfortable, efficient and boasting the very best components to help you ride further, higher and faster than before. From the huge range of Shimano's XT gears to the superb power and controllability of the four-piston XT hydraulic discs with oversize 203mm rotors, there's no compromise in tactility or function. Even better, our new Stereo Hybrid 120 chassis enabled our engineers to fine-tune this legendary bike's performance even further. The Modular Battery System completely encloses the Bosch power unit in the gravity cast down tube for sleek looks, protection against the elements and enough room for a bigger battery with even more range than before. Meanwhile Bosch's fourth-generation CX drive unit and Kiox controller transfer power efficiently and quietly to the rear wheel, helped by the rigidity of the Boost 148 rear end. The trunnion mount Fox Float DPS Performance rear shock and Fox 34 Rhythm fork work in perfect harmony, thanks partly to the experience and engineering expertise of our design team and their finely tuned, four-bar suspension system and Agile Comfort Geometry. With a remote dropper post, grippy 2.6in Schwalbe tyres and wide Newmen Evolution handlebar, you'll always be in full control of the situation, wherever you happen to find yourself. We sweated the details – including making it kickstand-ready – so that the only sweat you'll expend is working out where to go next...

★ **335202** Cube Stereo Hybrid 120 SL 625 29 black'n'grey 2020

**FRAME** Aluminum Superlite, Gravity Casting Technology, Efficient Comfort Control, FSP 4-Link, Agile Comfort Geometry, Boost 148, Full Integrated Battery, Kickstand/Fender/Carrier Mounting Points  
**SIZE** #6", 18", 20", 22"  
**FORK** #Fox 34 Rhythm, 2-Position Sweep-Adjust GRIP Damper, Tapered, 15x110mm, E-Bike Tune, 120mm  
**SHOCK** #Fox Float DPS EVOL, 185x55mm, Open/Medium/Firm Mode, Trunnion Mount  
**SHOCK HARDWARE** #Top: 54mm Trunnion Mount, Bottom: 30x8mm

**DRIVE UNIT** #Bosch Drive Unit Performance CX Generation 4 (75Nm) Cruise (250Watt)  
**BATTERY** #Bosch PowerTube 625  
**DISPLAY** #Bosch Kiox  
**CHARGER** #Bosch 4A

**HEADSET** #SA Orbit Z 1.5E ZS, Top Zero-Stack 1 1/2" (OD 56mm), Bottom Zero-Stack 1 1/2" (OD 56mm)  
**STEM** #CUBE Performance Stem E-MTB, 31.8mm  
**HANDLEBAR** #Newmen Evolution SL 318.25, 760mm  
**GRIPS** #Natural Fit All Terrain  
**REAR DERAILLEUR** #Shimano XT RD-M8100-SGS, ShadowPlus, 12-Speed  
**SHIFTERS** #Shimano XT SL-M8100-IR, Direct Attach  
**BRAKE SYSTEM** #Shimano XT BR-M8120, Hydr. Disc Brake (203/203)  
**CRANKSET** #thirteen Plus Crank, 38T, 170mm  
**CASSETTE** #Shimano XT CS-M8100, 10-51T  
**CHAIN** #Shimano XT CN-M8100  
**RIMS** #CUBE EX30, 32H, Disc, Tubeless Ready  
**FRONT HUB** #Shimano HB-MT400-B, 15mm, Boost, Centerlock  
**REAR HUB** #Shimano FH-MT510-B, 12mm, Boost, Centerlock  
**TYRES** #Schwalbe Smart Sam, Performance, Kevlar, 2.60  
**PEDALS** #CUBE PP MTB  
**SADDLE** #Natural Fit Sequence+  
**SEAT POST** #CUBE Dropper Post, Handlebar Lever, Internal Cable Routing, 30.9mm (16": 361x100mm; 18": 403x120mm; 20": 425x130mm)  
**SEATCLAMP** #CUBE Varioclose Semi Integrated, 34.9mm

**SPARE PARTS**  
**8000** CUBE Headset Orbit Z 1.5E ZS  
**8528** CUBE BEARING\_pivot set-Ø15x87.4 (18-02089)  
**8529** CUBE AXLE\_pivot set-shock mount (18-02849)  
**8539** CUBE BEARING\_pivot set-Ø10x23,5  
**8540** CUBE BEARING\_pivot set-horst link  
**8651** CUBE HANGER\_mtb-x12-std-2020 (18-05516)

**WEIGHT** #4,3 kg



**13816**  
CUBESTAND PRO

**93078**  
ACID MUDGUARD SET MTB 75

**93097**  
ACID REAR CARRIER SIC 29" BOOST RILINK

FULLSUSPENSION

# STEREO HYBRID 120 RACE 29

frozensgreen'n'green



There's no point hiding behind false modesty: The Stereo Hybrid 120 Race is a bit of a Bosch e-bike legend in its own lifetime, and that's something that we're rather proud of. Completely redesigned for 2020, we've taken its reputation for exceptional handling and comfort and given it a thorough makeover to make it more practical, easier to use and better looking than ever. Key to the improvements are the design details of the brand-new frame, which centres around our new Modular Battery System and vented motor housing with one-screw cover. The completely enclosed battery – with push-button cover and hidden lock – keeps the power unit safe from dust and moisture, contributes to the frame's incredibly sleek appearance, and allows the option of a more powerful battery for even greater range. The Trunnion shock mount, Boost 148 rear end and oversized, straight 1.5in head tube all contribute to super handling and comfort in any trail scenario, aided and abetted by our acclaimed Agile Comfort Geometry. With a Fox Float DPS Performance shock at the rear and Fox 34 Rhythm fork up front, the ride is as comfortable as you could wish for. Shimano's incredible 12-speed SLX and XT transmission components offer an unparalleled gear range for effortless hill climbing and all-round ability, whilst the fourth-generation Bosch CX drive unit serves up smooth, quiet power assistance for mile after mile. Big-volume, grippy Schwalbe tyres roll easily in any terrain and Shimano's reliably powerful four-piston hydraulic brakes ensure you're always in full control. We even made it easy to add a kickstand, so you can wave goodbye to finding a convenient tree or lamp post. Put it all together, and the Stereo Hybrid 120 Race has the capability to take your adventures further. The only remaining question is, where will you ride tomorrow?

- ★ **335167** Cube Stereo Hybrid 120 Race 625 29 frozensgreen'n'green 2020
- ★ **335166** Cube Stereo Hybrid 120 Race 500 29 frozensgreen'n'green 2020

**FRAME#** Aluminum Superlite, Gravity Casting Technology, Efficient Comfort Control, FSP 4-Link, Agile Comfort Geometry, Boost 148, Full Integrated Battery, Kickstand/Fender/Carrier Mounting Points  
**SIZE#** 6", 18", 20", 22"  
**FORK#** Fox 34 Rhythm, 2-Position Sweep-Adjust GRIP Damper, Tapered, 15x110mm, E-Bike Tune, 120mm  
**SHOCK#** Fox Float DPS EVOL, 185x55mm, Open/Medium/Firm Mode, Trunnion Mount  
**SHOCK HARDWARE#** op: 54mm Trunnion Mount, Bottom: 30x8mm

**DRIVE UNIT#** Bosch Drive Unit Performance CX Generation 4 (75Nm) Cruise (250Watt)  
**BATTERY#** Bosch PowerTube 625  
**DISPLAY#** Bosch Kiox  
**CHARGER#** Bosch 2A

**HEADSET#** SA Orbit Z 1.5B ZS, Top Zero-Stack 1 1/2" (OD 56mm), Bottom Zero-Stack 1 1/2" (OD 56mm)  
**STEM#** CUBE Performance Stem E-MTB, 31.8mm  
**HANDLEBAR#** Newmen Evolution SL 318.25, 760mm  
**GRIPS#** Natural Fit All Terrain  
**REAR DERAILLEUR#** Shimano XT RD-M8100-SGS, ShadowPlus, 12-Speed  
**SHIFTERS#** Shimano SLX SL-M7100  
**BRAKE SYSTEM#** Shimano BR-MT420, Hydr. Disc Brake (203/203)  
**CRANKSET#** CID E-Crank, 38T, 170mm  
**CASSETTE#** Shimano SLX CS-M7100, 10-51T  
**CHAIN#** Shimano SLX CN-M7100  
**RIMS#** CUBE EX30, 32H, Disc, Tubeless Ready  
**FRONT HUB#** Shimano HB-MT400-B, 15mm, Boost, Centerlock  
**REAR HUB#** Shimano FH-MT510-B, 12mm, Boost, Centerlock  
**TYRES#** Schwalbe Smart Sam, Active, 2.60  
**PEDALS#** CUBE PP MTB  
**SADDLE#** Natural Fit Sequence+  
**SEAT POST#** CUBE Performance Post, 30.9mm  
**SEATCLAMP#** CUBE Varioclose Semi Integrated, 34.9mm

**SPARE PARTS#**

- 8000** CUBE Headset Orbit Z 1.5E ZS
- 8528** CUBE BEARING\_pivot set-Ø15x87.4 (18-02089)
- 8529** CUBE AXLE\_pivot set-shock mount (18-02849)
- 8539** CUBE BEARING\_pivot set-Ø10x23,5
- 8540** CUBE BEARING\_pivot set-horst link
- 8651** CUBE HANGER\_mtb-x12-std-2020 (18-05516)

**WEIGHT#** 4,4 kg

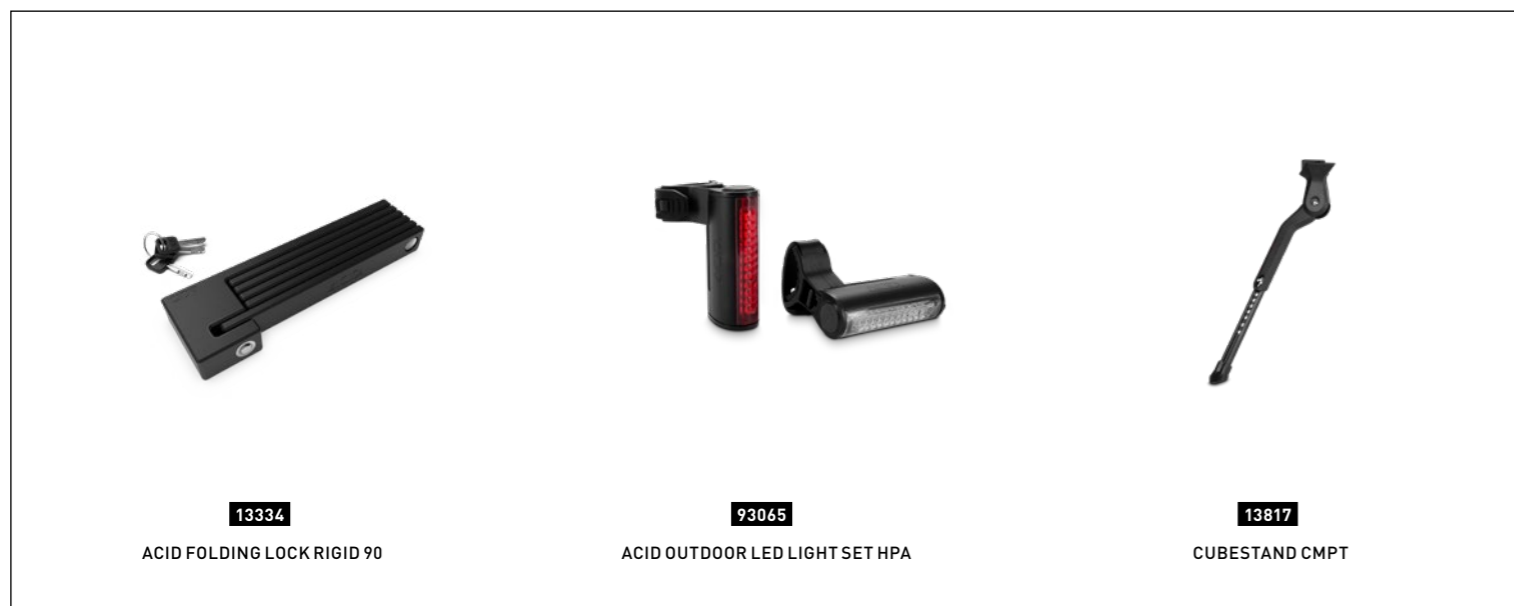

**13334**  
ACID FOLDING LOCK RIGID 90

**93065**  
ACID OUTDOOR LED LIGHT SET HPA

**13817**  
CUBE STAND CMPT

FULLSUSPENSION

# STEREO HYBRID 120 RACE 29

grey'n'orange



FULLSUSPENSION

There's no point hiding behind false modesty: The Stereo Hybrid 120 Race is a bit of a Bosch e-bike legend in its own lifetime, and that's something that we're rather proud of. Completely redesigned for 2020, we've taken its reputation for exceptional handling and comfort and given it a thorough makeover to make it more practical, easier to use and better looking than ever. Key to the improvements are the design details of the brand-new frame, which centres around our new Modular Battery System and vented motor housing with one-screw cover. The completely enclosed battery – with push-button cover and hidden lock – keeps the power unit safe from dust and moisture, contributes to the frame's incredibly sleek appearance, and allows the option of a more powerful battery for even greater range. The Trunnion shock mount, Boost 148 rear end and oversized, straight 1.5in head tube all contribute to super handling and comfort in any trail scenario, aided and abetted by our acclaimed Agile Comfort Geometry. With a Fox Float DPS Performance shock at the rear and Fox 34 Rhythm fork up front, the ride is as comfortable as you could wish for. Shimano's incredible 12-speed SLX and XT transmission components offer an unparalleled gear range for effortless hill climbing and all-round ability, whilst the fourth-generation Bosch CX drive unit serves up smooth, quiet power assistance for mile after mile. Big-volume, grippy Schwalbe tyres roll easily in any terrain and Shimano's reliably powerful four-piston hydraulic brakes ensure you're always in full control. We even made it easy to add a kickstand, so you can wave goodbye to finding a convenient tree or lamp post. Put it all together, and the Stereo Hybrid 120 Race has the capability to take your adventures further. The only remaining question is, where will you ride tomorrow?

- ★ **335162** Cube Stereo Hybrid 120 Race 625 29 grey'n'orange 2020
- ★ **335161** Cube Stereo Hybrid 120 Race 500 29 grey'n'orange 2020

**FRAME** # Aluminum Superlite, Gravity Casting Technology, Efficient Comfort Control, FSP 4-Link, Agile Comfort Geometry, Boost 148, Full Integrated Battery, Kickstand/Fender/Carrier Mounting Points  
**SIZE** # 6", 18", 20", 22"  
**FORK** # Fox 34 Rhythm, 2-Position Sweep-Adjust GRIP Damper, Tapered, 15x110mm, E-Bike Tune, 120mm  
**SHOCK** # Fox Float DPS EVOL, 185x55mm, Open/Medium/Firm Mode, Trunnion Mount  
**SHOCK HARDWARE** # Top: 54mm Trunnion Mount, Bottom: 30x8mm

**DRIVE UNIT** # Bosch Drive Unit Performance CX Generation 4 (75Nm) Cruise (250Watt)  
**BATTERY** # Bosch PowerTube 625  
**DISPLAY** # Bosch Kiox  
**CHARGER** # Bosch 2A

**HEADSET** # SA Orbit Z 1.5B ZS, Top Zero-Stack 1 1/2" [OD 56mm], Bottom Zero-Stack 1 1/2" [OD 56mm]  
**STEM** # CUBE Performance Stem E-MTB, 31.8mm  
**HANDLEBAR** # Newmen Evolution SL 318.25, 760mm  
**GRIPS** # Natural Fit All Terrain  
**REAR DERAILLEUR** # Shimano XT RD-M8100-SGS, ShadowPlus, 12-Speed  
**SHIFTERS** # Shimano SLX SL-M7100  
**BRAKE SYSTEM** # Shimano BR-MT420, Hydr. Disc Brake (203/203)  
**CRANKSET** # ACID E-Crank, 38T, 170mm  
**CASSETTE** # Shimano SLX CS-M7100, 10-51T  
**CHAIN** # Shimano SLX CN-M7100  
**RIMS** # CUBE EX30, 32H, Disc, Tubeless Ready  
**FRONT HUB** # Shimano HB-MT400-B, 15mm, Boost, Centerlock  
**REAR HUB** # Shimano FH-MT510-B, 12mm, Boost, Centerlock  
**TYRES** # Schwalbe Smart Sam, Active, 2.60  
**PEDALS** # CUBE PP MTB  
**SADDLE** # Natural Fit Sequence+  
**SEAT POST** # CUBE Performance Post, 30.9mm  
**SEATCLAMP** # CUBE Varioclose Semi Integrated, 34.9mm

**SPARE PARTS**

- 8000** CUBE Headset Orbit Z 1.5E ZS
- 8528** CUBE BEARING\_pivot set-Ø15x87.4 (18-02089)
- 8529** CUBE AXLE\_pivot set-shock mount (18-02849)
- 8539** CUBE BEARING\_pivot set-Ø10x23,5
- 8540** CUBE BEARING\_pivot set-horst link
- 8651** CUBE HANGER\_mtb-x12-std-2020 (18-05516)

**WEIGHT** # 4,4 kg



**17072**  
CUBE SHOES MTB PEAK



**10708**  
CUBE AM JERSEY



**16254**  
CUBE HELM ROK X ACTIONTEAM

# STEREO HYBRID 120 RACE 29

black'n'blue

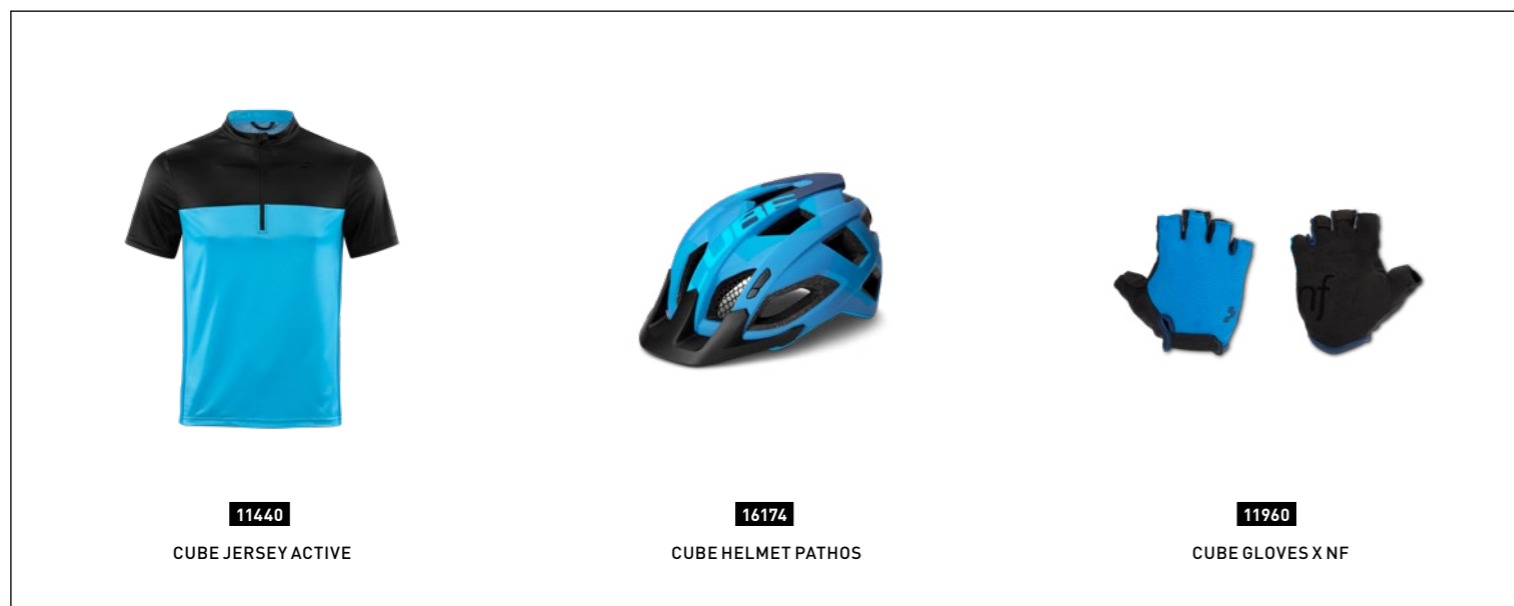

11440  
CUBE JERSEY ACTIVE



16174  
CUBE HELMET PATHOS



11940  
CUBE GLOVES X NF

There's no point hiding behind false modesty: The Stereo Hybrid 120 Race is a bit of a Bosch e-bike legend in its own lifetime, and that's something that we're rather proud of. Completely redesigned for 2020, we've taken its reputation for exceptional handling and comfort and given it a thorough makeover to make it more practical, easier to use and better looking than ever. Key to the improvements are the design details of the brand-new frame, which centres around our new Modular Battery System and vented motor housing with one-screw cover. The completely enclosed battery – with push-button cover and hidden lock – keeps the power unit safe from dust and moisture, contributes to the frame's incredibly sleek appearance, and allows the option of a more powerful battery for even greater range. The Trunnion shock mount, Boost 148 rear end and oversized, straight 1.5in head tube all contribute to super handling and comfort in any trail scenario, aided and abetted by our acclaimed Agile Comfort Geometry. With a Fox Float DPS Performance shock at the rear and Fox 34 Rhythm fork up front, the ride is as comfortable as you could wish for. Shimano's incredible 12-speed SLX and XT transmission components offer an unparalleled gear range for effortless hill climbing and all-round ability, whilst the fourth-generation Bosch CX drive unit serves up smooth, quiet power assistance for mile after mile. Big-volume, grippy Schwalbe tyres roll easily in any terrain and Shimano's reliably powerful four-piston hydraulic brakes ensure you're always in full control. We even made it easy to add a kickstand, so you can wave goodbye to finding a convenient tree or lamp post. Put it all together, and the Stereo Hybrid 120 Race has the capability to take your adventures further. The only remaining question is, where will you ride tomorrow?

- ★ 335152 Cube Stereo Hybrid 120 Race 625 29 black'n'blue 2020
- 335151 Cube Stereo Hybrid 120 Race 500 29 black'n'blue 2020

**FRAME#** Aluminum Superlite, Gravity Casting Technology, Efficient Comfort Control, FSP 4-Link, Agile Comfort Geometry, Boost 148, Full Integrated Battery, Kickstand/Fender/Carrier Mounting Points  
**SIZE#** 6", 18", 20", 22"  
**FORK#** Fox 34 Rhythm, 2-Position Sweep-Adjust GRIP Damper, Tapered, 15x110mm, E-Bike Tune, 120mm  
**SHOCK#** Fox Float DPS EVOL, 185x55mm, Open/Medium/Firm Mode, Trunnion Mount  
**SHOCK HARDWARE#** Top: 54mm Trunnion Mount, Bottom: 30x8mm

**DRIVE UNIT#** Bosch Drive Unit Performance CX Generation 4 (75Nm) Cruise (250Watt)  
**BATTERY#** Bosch PowerTube 625  
**DISPLAY#** Bosch Kiox  
**CHARGER#** Bosch 2A

**HEADSET#** SA Orbit Z 1.5B ZS, Top Zero-Stack 1 1/2" [OD 56mm], Bottom Zero-Stack 1 1/2" [OD 56mm]  
**STEM#** CUBE Performance Stem E-MTB, 31.8mm  
**HANDLEBAR#** Newmen Evolution SL 318.25, 760mm  
**GRIPS#** Natural Fit All Terrain  
**REAR DERAILLEUR#** Shimano XT RD-M8100-SGS, ShadowPlus, 12-Speed  
**SHIFTERS#** Shimano SLX SL-M7100  
**BRAKE SYSTEM#** Shimano BR-MT420, Hydr. Disc Brake (203/203)  
**CRANKSET#** CID E-Crank, 38T, 170mm  
**CASSETTE#** Shimano SLX CS-M7100, 10-51T  
**CHAIN#** Shimano SLX CN-M7100  
**RIMS#** CUBE EX30, 32H, Disc, Tubeless Ready  
**FRONT HUB#** Shimano HB-MT400-B, 15mm, Boost, Centerlock  
**REAR HUB#** Shimano FH-MT510-B, 12mm, Boost, Centerlock  
**TYRES#** Schwalbe Smart Sam, Active, 2.60  
**PEDALS#** CUBE PP MTB  
**SADDLE#** Natural Fit Sequence+  
**SEAT POST#** CUBE Performance Post, 30.9mm  
**SEATCLAMP#** CUBE Varioclose Semi Integrated, 34.9mm

**SPARE PARTS#**

- 8000 CUBE Headset Orbit Z 1.5E ZS
- 8528 CUBE BEARING\_pivot set-Ø15x87.4 (18-02089)
- 8529 CUBE AXLE\_pivot set-shock mount (18-02849)
- 8539 CUBE BEARING\_pivot set-Ø10x23,5
- 8540 CUBE BEARING\_pivot set-horst link
- 8651 CUBE HANGER\_mtb-x12-std-2020 (18-05516)

**WEIGHT#** 4,4 kg

FULLSUSPENSION



# STEREO HYBRID 120 RACE ALLROAD 29

black'n'blue

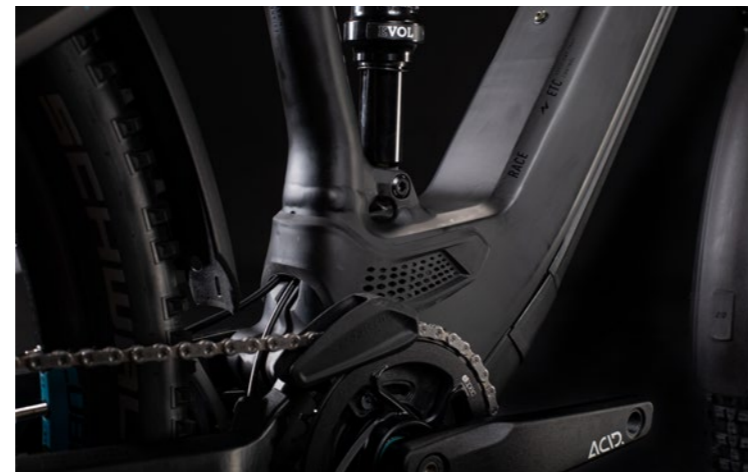

There are times in life when it definitely helps to have the right tool for the job. With the Stereo Hybrid 120 Race Allroad, we've created a versatile and extremely well-equipped Bosch e-bike that's capable of taking on just about anything. A day ride at the trail centre? It's got you covered. A longer overnight trip at the weekend? The luggage carrier will certainly come in handy. Stand-in for the weekday commute? In that case, the included mudguards, lights, bell and kickstand will definitely come in handy. But don't be fooled – none of this practicality comes at the expense of performance. Completely redesigned for 2020, the Stereo Hybrid Race Allroad's frame is a masterpiece of e-bike full suspension engineering – the culmination of our engineering team's many years of experience in this area. Centrepiece of the new chassis is our Modular Battery System, which combines sleek looks with superb function by completely enclosing the Bosch power unit inside the gravity cast down tube. The push-button cover with hidden lock makes it incredibly easy to access, but it also protects against dirt and moisture ingress. And the reconfigured housing frees up even more space, so there's the option of a bigger battery for extended range. The Fox Float DPS Performance rear shock and Fox 34 Rhythm fork are state of the art, slotting seamlessly into our advanced four-bar suspension design to deliver sublime comfort and control, wherever your adventures take you. Bosch's fourth-generation drive unit tops up your pedal input, delivering masses of smooth, quiet torque to the rear wheel via Shimano's slick and reliable 12-speed SLX and XT gear components. And, of course, we've selected powerful Shimano four-piston hydraulic disc brakes to bring you reliably to a halt, whether on a dusty trail or a wet city street. Jack of all trades? Perhaps. But it's also master of them all.

- ★ **335172** Cube Stereo Hybrid 120 Race 625 Allroad 29 black'n'blue 2020
- ★ **335171** Cube Stereo Hybrid 120 Race 500 Allroad 29 black'n'blue 2020

**FRAME** # Aluminum Superlite, Gravity Casting Technology, Efficient Comfort Control, FSP 4-Link, Agile Comfort Geometry, Boost 148, Full Integrated Battery, Kickstand/Fender/Carrier Mounting Points  
**SIZE** # 6", 18", 20", 22"  
**FORK** # Fox 34 Rhythm, 2-Position Sweep-Adjust GRIP Damper, Tapered, 15x110mm, E-Bike Tune, 120mm  
**SHOCK** # Fox Float DPS EVOL, 185x55mm, Open/Medium/Firm Mode, Trunnion Mount  
**SHOCK HARDWARE** # Top: 54mm Trunnion Mount, Bottom: 30x8mm

**DRIVE UNIT** # Bosch Drive Unit Performance CX Generation 4 (75Nm) Cruise (250Watt)  
**BATTERY** # Bosch PowerTube 625  
**DISPLAY** # Bosch Kiox  
**CHARGER** # Bosch 2A

**HEADSET** # SA Orbit Z 1.5B ZS, Top Zero-Stack 1 1/2" (OD 56mm), Bottom Zero-Stack 1 1/2" (OD 56mm)  
**STEM** # CUBE Performance Stem E-MTB, 31.8mm  
**HANDLEBAR** # Newmen Evolution SL 318.25, 760mm  
**GRIPS** # Natural Fit All Terrain  
**REAR DERAILLEUR** # Shimano XT RD-M8100-SGS, ShadowPlus, 12-Speed  
**SHIFTERS** # Shimano SLX SL-M7100  
**BRAKE SYSTEM** # Shimano BR-MT420, Hydr. Disc Brake (203/203)  
**CRANKSET** # CID E-Crank, 38T, 170mm  
**CASSETTE** # Shimano SLX CS-M7100, 10-51T  
**CHAIN** # Shimano SLX CN-M7100  
**RIMS** # CUBE EX30, 32H, Disc, Tubeless Ready  
**FRONT HUB** # Shimano HB-MT400-B, 15mm, Boost, Centerlock  
**REAR HUB** # Shimano FH-MT510-B, 12mm, Boost, Centerlock  
**TYRES** # Schwalbe Smart Sam, Active, 2.35  
**PEDALS** # CUBE PP MTB  
**SADDLE** # Natural Fit Sequence+  
**SEAT POST** # CUBE Performance Post, 30.9mm  
**SEATCLAMP** # CUBE Varioclose Semi Integrated, 34.9mm  
**FRONT LIGHT** # ezyne Power E115, X-Lock Mount, 6-12V, DC  
**REAR LIGHT** # Busch & Müller Xeltec, DC  
**KICKSTAND** # CUBE Stand Pro, Adjustable  
**MUDGUARDS** # CID 75  
**BELL** # knog Oi  
**CARRIER** # CID Semi-Integrated Carrier, ACID RiLink Adapter Compatible

- SPARE PARTS**
- 8000** CUBE Headset Orbit Z 1.5E ZS
  - 8528** CUBE BEARING\_pivot set-Ø15x87.4 (18-02089)
  - 8529** CUBE AXLE\_pivot set-shock mount (18-02849)
  - 8539** CUBE BEARING\_pivot set-Ø10x23,5
  - 8540** CUBE BEARING\_pivot set-horst link
  - 8651** CUBE HANGER\_mtb-x12-std-2020 (18-05516)

**WEIGHT** # 5,8 kg

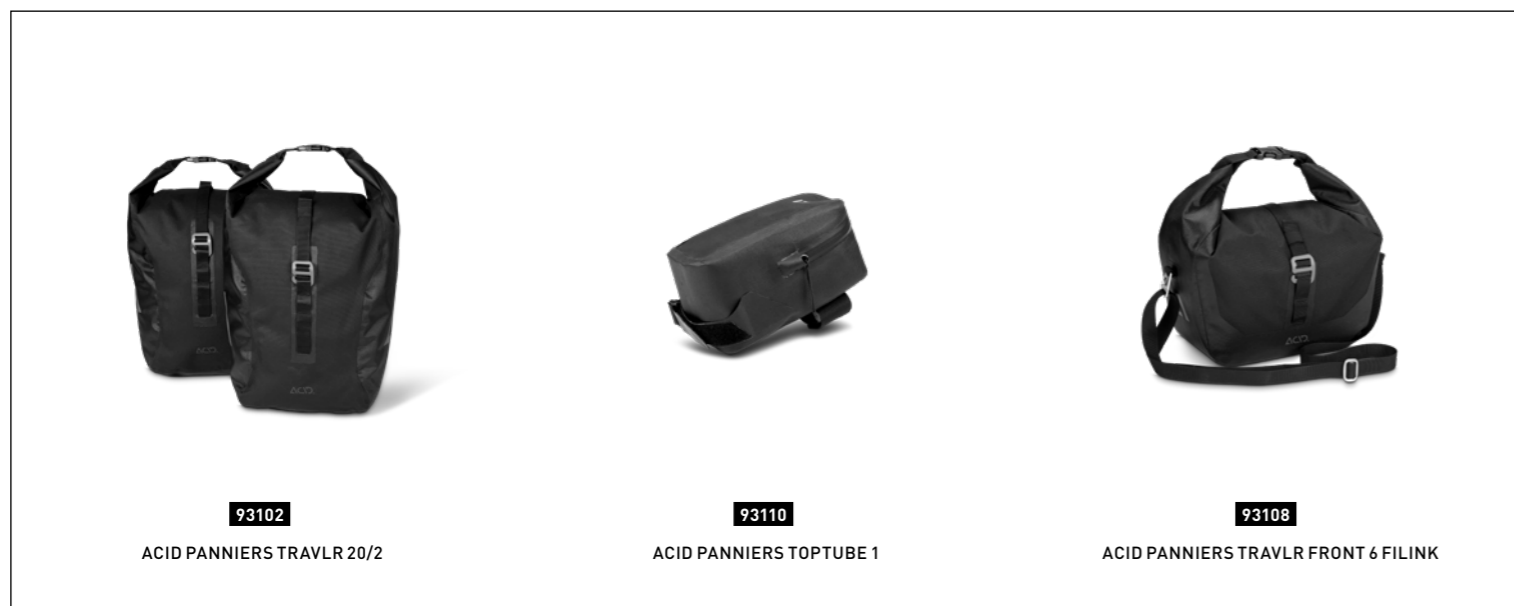

**93102**  
ACID PANNIERS TRAVLR 20/2

**93110**  
ACID PANNIERS TOPTUBE 1

**93108**  
ACID PANNIERS TRAVLR FRONT 6 FILINK

# STEREO HYBRID 120 PRO 29

petrol 'n' red

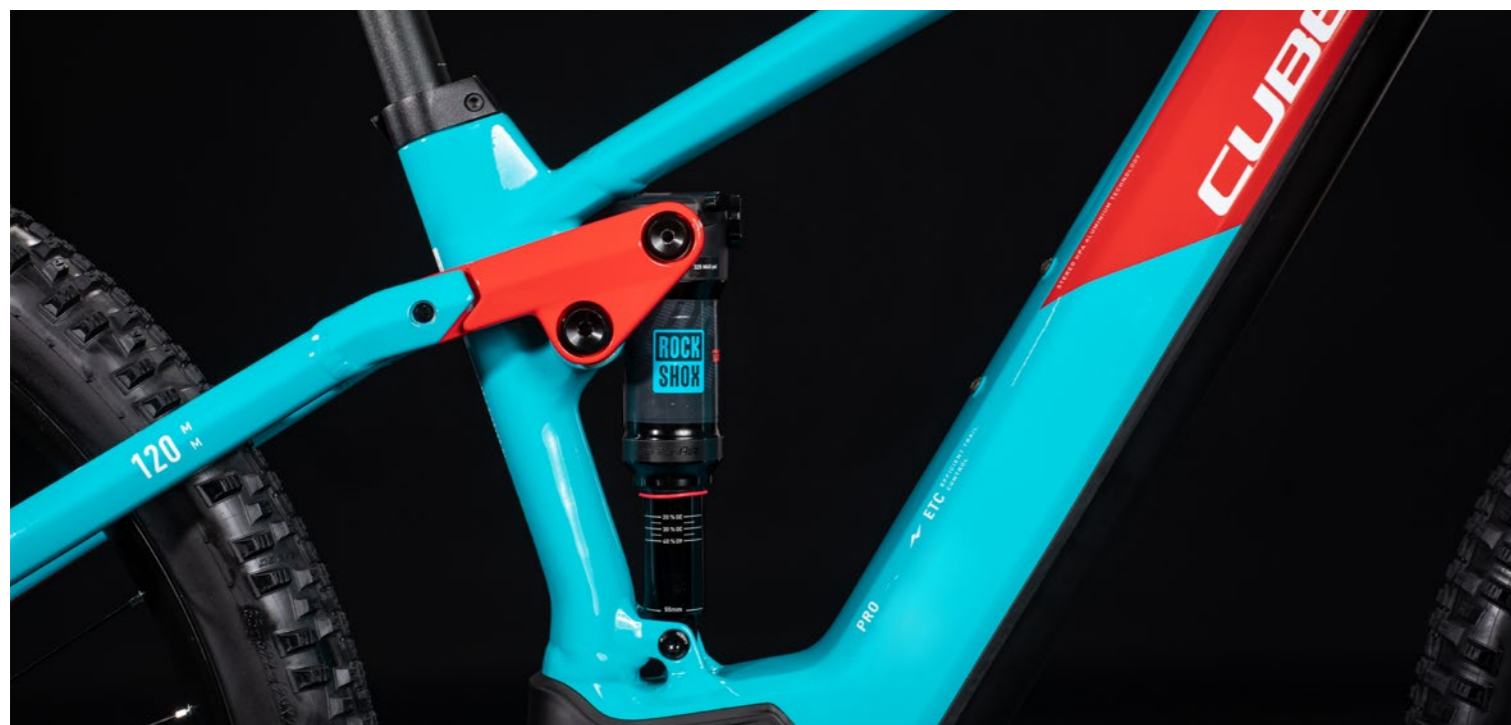

FULLSUSPENSION

When your off-road ambitions begin to shift from exploring to adventure, it helps to have a bike that'll make your life a little easier. Our ever-popular, trail-taming Stereo Hybrid 120 Pro is that bike. Completely redesigned for 2020, its comfortable, stable handling, smooth Bosch drive unit and plush CUBE suspension system add up to an incredibly effective way to expand your trail riding horizons: a Bosch e-bike for explorers. Our brand-new CUBE Modular Battery System houses the power unit discreetly in the gravity cast down tube, with a push-button battery cover and hidden lock. This doesn't just look great, it also keeps it safe from dirt and water, and gives the option of an even bigger capacity battery for extended range. The brand-new, fourth-generation Bosch motor is housed in a vented enclosure with easy one-screw access, seamlessly super-charging your pedalling by transferring its power to the Boost 148 rear end via Sram's easy-to-use, incredibly wide-ranging SX Eagle 12-speed transmission. Agile Comfort Geometry puts you in charge and looks after your comfort, too, thanks to our sophisticated four-bar suspension design and Trunnion RockShox Deluxe Select shock and RockShox Judy Silver air fork. And, when it comes to descending the climb you've just breezed up in less time than you thought possible, powerful Shimano hydraulic disc brakes combined with 2.6in Schwalbe Smart Sam tyres ensure that you've got all the grip and control that you need. We even made the frame kickstand-ready, so you don't need to rely on the nearest wall or tree. Wherever your riding takes you, the Stereo Hybrid 120 Pro gives you the inspiring control, ground-hugging comfort and Bosch e-power boost you need to explore further.

- ★ **335072** Cube Stereo Hybrid 120 Pro 625 29 petrol 'n' red 2020
- ★ **335071** Cube Stereo Hybrid 120 Pro 500 29 petrol 'n' red 2020

**FRAME** #Aluminum Superlite, Gravity Casting Technology, Efficient Comfort Control, FSP 4-Link, Agile Comfort Geometry, Boost 148, Full Integrated Battery, Kickstand/Fender/Carrier Mounting Points  
**SIZE** #6", 18", 20", 22"  
**FORK** #RockShox Recon RL Air, Tapered, 15x110mm, eMTB Approved, 120mm  
**SHOCK** #RockShox Deluxe Select, 185x55mm, Rebound Adjust, Trunnion Mount  
**SHOCK HARDWARE** #Top: 54mm Trunnion Mount, Bottom: 30x8mm

**DRIVE UNIT** #Bosch Drive Unit Performance CX Generation 4 (75Nm) Cruise (250Watt)  
**BATTERY** #Bosch PowerTube 625  
**DISPLAY** #Bosch Kiox  
**CHARGER** #Bosch 2A

**HEADSET** #SA Orbit Z 1.5E ZS, Top Zero-Stack 1 1/2" (OD 56mm), Bottom Zero-Stack 1 1/2" (OD 56mm)  
**STEM** #CUBE Performance Stem E-MTB, 31.8mm  
**HANDLEBAR** #Newmen Evolution SL 318.25, 760mm  
**GRIPS** #Natural Fit All Terrain  
**REAR DERAILLEUR** #Sram SX Eagle™, 12-Speed  
**SHIFTERS** #Sram SX Eagle™ Trigger, Single Click  
**BRAKE SYSTEM** #Shimano BR-MT420/MT400, Hydr. Disc Brake (203/180)  
**CRANKSET** #CID E-Crank, 38T, 170mm  
**CASSETTE** #Sram PG-1210 Eagle™, 11-50T  
**CHAIN** #Sram SX Eagle™  
**RIMS** #CUBE EX30, 32H, Disc, Tubeless Ready  
**FRONT HUB** #Shimano HB-MT400-B, 15mm, Boost, Centerlock  
**REAR HUB** #Shimano FH-MT400-B, 12mm, Boost, Centerlock  
**TYRES** #Schwalbe Smart Sam, Active, 2.60  
**PEDALS** #CUBE PP MTB  
**SADDLE** #Natural Fit Sequence  
**SEAT POST** #CUBE Performance Post, 30.9mm  
**SEATCLAMP** #CUBE Varioclose Semi Integrated, 34.9mm

- SPARE PARTS**
- 8000** CUBE Headset Orbit Z 1.5E ZS
  - 8528** CUBE BEARING\_pivot set-Ø15x87.4 (18-02089)
  - 8529** CUBE AXLE\_pivot set-shock mount (18-02849)
  - 8539** CUBE BEARING\_pivot set-Ø10x23,5
  - 8540** CUBE BEARING\_pivot set-horst link
  - 8651** CUBE HANGER\_mtb-x12-std-2020 (18-05516)

**WEIGHT** #4,9 kg

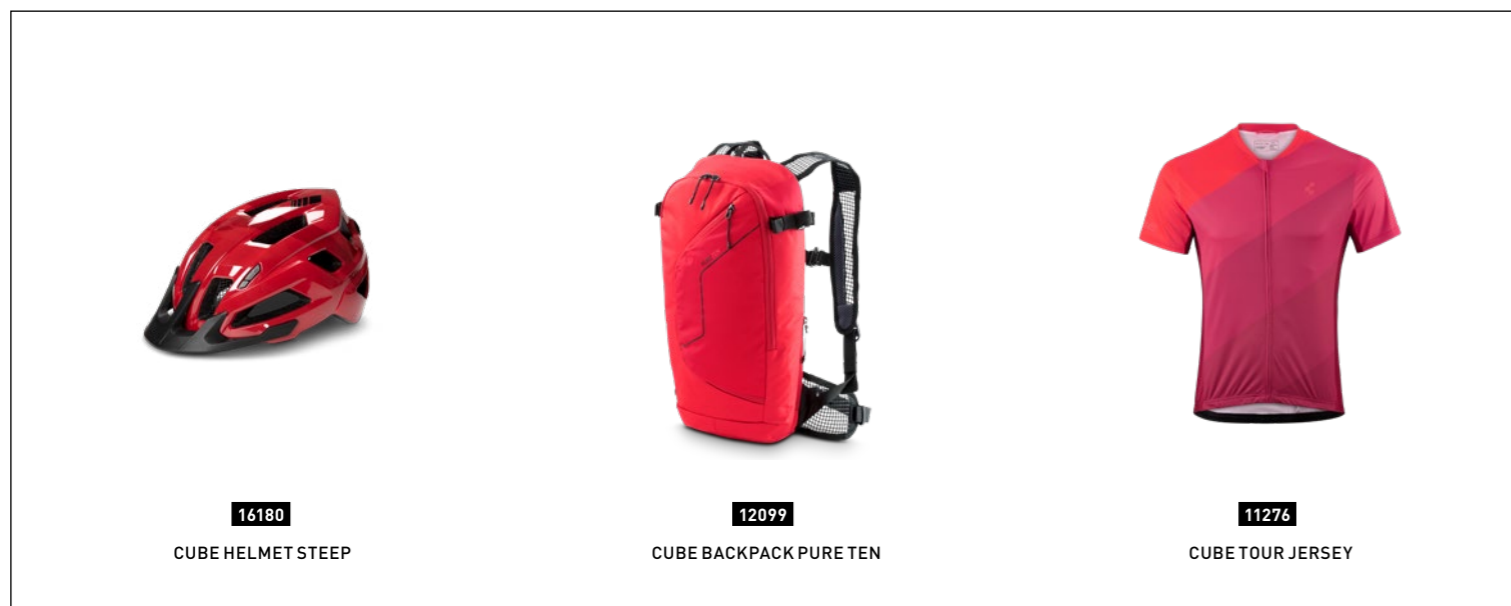

**16180**  
CUBE HELMET STEEP

**12099**  
CUBE BACKPACK PURE TEN

**11276**  
CUBE TOUR JERSEY



# STEREO HYBRID 120 PRO 29

green'n'green



When your off-road ambitions begin to shift from exploring to adventure, it helps to have a bike that'll make your life a little easier. Our ever-popular, trail-taming Stereo Hybrid 120 Pro is that bike. Completely redesigned for 2020, its comfortable, stable handling, smooth Bosch drive unit and plush CUBE suspension system add up to an incredibly effective way to expand your trail riding horizons: a Bosch e-bike for explorers. Our brand-new CUBE Modular Battery System houses the power unit discreetly in the gravity cast down tube, with a push-button battery cover and hidden lock. This doesn't just look great, it also keeps it safe from dirt and water, and gives the option of an even bigger capacity battery for extended range. The brand-new, fourth-generation Bosch motor is housed in a vented enclosure with easy one-screw access, seamlessly super-charging your pedalling by transferring its power to the Boost 148 rear end via Sram's easy-to-use, incredibly wide-ranging SX Eagle 12-speed transmission. Agile Comfort Geometry puts you in charge and looks after your comfort, too, thanks to our sophisticated four-bar suspension design and Trunnion RockShox Deluxe Select shock and RockShox Judy Silver air fork. And, when it comes to descending the climb you've just breezed up in less time than you thought possible, powerful Shimano hydraulic disc brakes combined with 2.6in Schwalbe Smart Sam tyres ensure that you've got all the grip and control that you need. We even made the frame kickstand-ready, so you don't need to rely on the nearest wall or tree. Wherever your riding takes you, the Stereo Hybrid 120 Pro gives you the inspiring control, ground-hugging comfort and Bosch e-power boost you need to explore further.

- ★ **335062** Cube Stereo Hybrid 120 Pro 625 29 green'n'green 2020
- ★ **335061** Cube Stereo Hybrid 120 Pro 500 29 green'n'green 2020

**FRAME** Aluminum Superlite, Gravity Casting Technology, Efficient Comfort Control, FSP 4-Link, Agile Comfort Geometry, Boost 148, Full Integrated Battery, Kickstand/Fender/Carrier Mounting Points  
**SIZE** #6", 18", 20", 22"  
**FORK** RockShox Recon RL Air, Tapered, 15x110mm, eMTB Approved, 120mm  
**SHOCK** RockShox Deluxe Select, 185x55mm, Rebound Adjust, Trunnion Mount  
**SHOCK HARDWARE** #top: 54mm Trunnion Mount, Bottom: 30x8mm

**DRIVE UNIT** Bosch Drive Unit Performance CX Generation 4 (75Nm) Cruise (250Watt)  
**BATTERY** Bosch PowerTube 625  
**DISPLAY** Bosch Kiox  
**CHARGER** Bosch 2A

**HEADSET** #SA Orbit Z 1.5B ZS, Top Zero-Stack 1 1/2" (OD 56mm), Bottom Zero-Stack 1 1/2" (OD 56mm)  
**STEM** #CUBE Performance Stem E-MTB, 31.8mm  
**HANDLEBAR** #Newmen Evolution SL 318.25, 760mm  
**GRIPS** #Natural Fit All Terrain  
**REAR DERAILLEUR** #Sram SX Eagle™, 12-Speed  
**SHIFTERS** #Sram SX Eagle™ Trigger, Single Click  
**BRAKE SYSTEM** #Shimano BR-MT420/MT400, Hydr. Disc Brake (203/180)  
**CRANKSET** #CID E-Crank, 38T, 170mm  
**CASSETTE** #Sram PG-1210 Eagle™, 11-50T  
**CHAIN** #Sram SX Eagle™  
**RIMS** #CUBE EX30, 32H, Disc, Tubeless Ready  
**FRONT HUB** #Shimano HB-MT400-B, 15mm, Boost, Centerlock  
**REAR HUB** #Shimano FH-MT400-B, 12mm, Boost, Centerlock  
**TYRES** #Schwalbe Smart Sam, Active, 2.60  
**PEDALS** #CUBE PP MTB  
**SADDLE** #Natural Fit Sequence  
**SEAT POST** #CUBE Performance Post, 30.9mm  
**SEATCLAMP** #CUBE Varioclose Semi Integrated, 34.9mm

- SPARE PARTS**
- 8000** CUBE Headset Orbit Z 1.5E ZS
  - 8528** CUBE BEARING\_pivot set-Ø15x87.4 (18-02089)
  - 8529** CUBE AXLE\_pivot set-shock mount (18-02849)
  - 8539** CUBE BEARING\_pivot set-Ø10x23,5
  - 8540** CUBE BEARING\_pivot set-horst link
  - 8651** CUBE HANGER\_mtb-x12-std-2020 (18-05516)



**14325**  
RFR E-BIKE FRONT LIGHT TOUR 90



**93147**  
ACID E-BIKE REAR MUDGUARD LIGHT PRO E



**93046**  
ACID MUDGUARD SET MTB 75 WITH STAYS

FULLSUSPENSION

# STEREO HYBRID 120 PRO 29

black'n'red

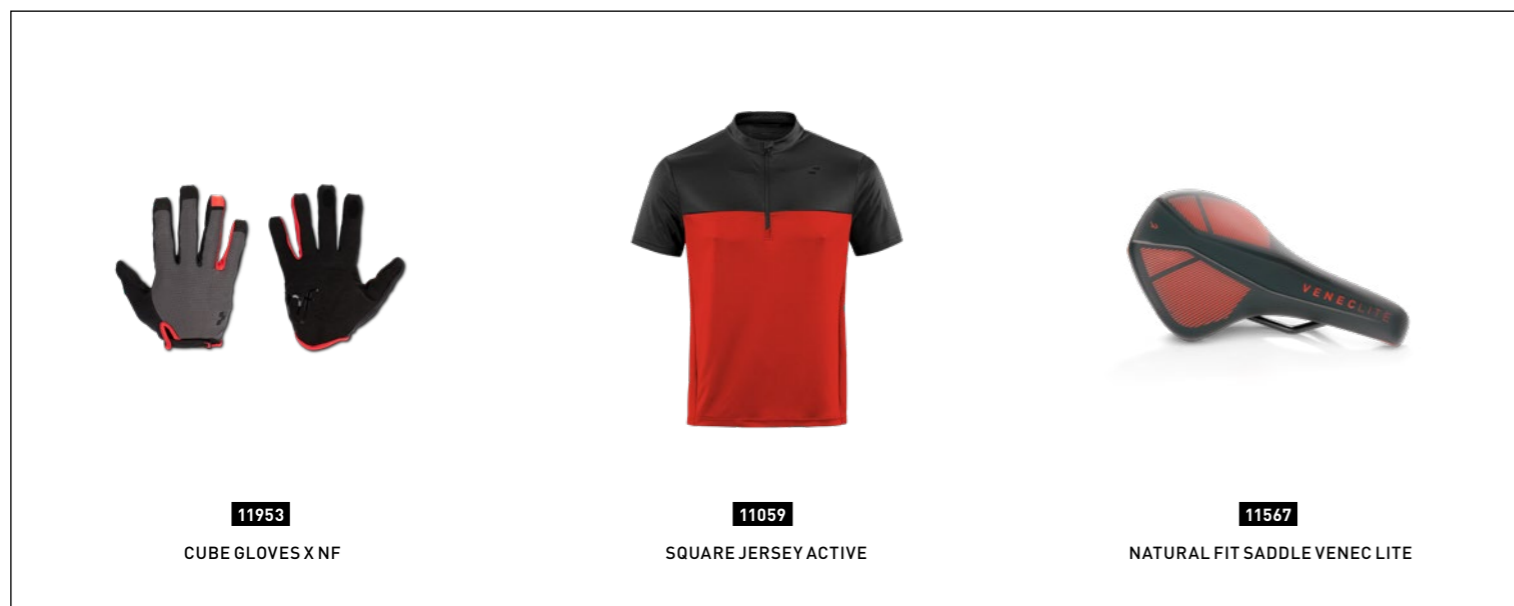

11953

CUBE GLOVES XNF



11059

SQUARE JERSEY ACTIVE



11567

NATURAL FIT SADDLE VENECLITE

When your off-road ambitions begin to shift from exploring to adventure, it helps to have a bike that'll make your life a little easier. Our ever-popular, trail-taming Stereo Hybrid 120 Pro is that bike. Completely redesigned for 2020, its comfortable, stable handling, smooth Bosch drive unit and plush CUBE suspension system add up to an incredibly effective way to expand your trail riding horizons: a Bosch e-bike for explorers. Our brand-new CUBE Modular Battery System houses the power unit discreetly in the gravity cast down tube, with a push-button battery cover and hidden lock. This doesn't just look great, it also keeps it safe from dirt and water, and gives the option of an even bigger capacity battery for extended range. The brand-new, fourth-generation Bosch motor is housed in a vented enclosure with easy one-screw access, seamlessly super-charging your pedalling by transferring its power to the Boost 148 rear end via Sram's easy-to-use, incredibly wide-ranging SX Eagle 12-speed transmission. Agile Comfort Geometry puts you in charge and looks after your comfort, too, thanks to our sophisticated four-bar suspension design and Trunnion RockShox Deluxe Select shock and RockShox Judy Silver air fork. And, when it comes to descending the climb you've just breezed up in less time than you thought possible, powerful Shimano hydraulic disc brakes combined with 2.6in Schwalbe Smart Sam tyres ensure that you've got all the grip and control that you need. We even made the frame kickstand-ready, so you don't need to rely on the nearest wall or tree. Wherever your riding takes you, the Stereo Hybrid 120 Pro gives you the inspiring control, ground-hugging comfort and Bosch e-power boost you need to explore further.

- ★ **335052** Cube Stereo Hybrid 120 Pro 625 29 black'n'red 2020
- 335051** Cube Stereo Hybrid 120 Pro 500 29 black'n'red 2020

**FRAME** Aluminum Superlite, Gravity Casting Technology, Efficient Comfort Control, FSP 4-Link, Agile Comfort Geometry, Boost 148, Full Integrated Battery, Kickstand/Fender/Carrier Mounting Points  
**SIZE** #6", 18", 20", 22"  
**FORK** #RockShox Recon RL Air, Tapered, 15x110mm, eMTB Approved, 120mm  
**SHOCK** #RockShox Deluxe Select, 185x55mm, Rebound Adjust, Trunnion Mount  
**SHOCK HARDWARE** #Top: 54mm Trunnion Mount, Bottom: 30x8mm

**DRIVE UNIT** #Bosch Drive Unit Performance CX Generation 4 (75Nm) Cruise (250Watt)  
**BATTERY** #Bosch PowerTube 625  
**DISPLAY** #Bosch Kiox  
**CHARGER** #Bosch 2A

**HEADSET** #SA Orbit Z 1.5B ZS, Top Zero-Stack 1 1/2" (OD 56mm), Bottom Zero-Stack 1 1/2" (OD 56mm)  
**STEM** #CUBE Performance Stem E-MTB, 31.8mm  
**HANDLEBAR** #Newmen Evolution SL 318.25, 760mm  
**GRIPS** #Natural Fit All Terrain  
**REAR DERAILLEUR** #Sram SX Eagle™, 12-Speed  
**SHIFTERS** #Sram SX Eagle™ Trigger, Single Click  
**BRAKE SYSTEM** #Shimano BR-MT420/MT400, Hydr. Disc Brake (203/180)  
**CRANKSET** #CID E-Crank, 38T, 170mm  
**CASSETTE** #Sram PG-1210 Eagle™, 11-50T  
**CHAIN** #Sram SX Eagle™  
**RIMS** #CUBE EX30, 32H, Disc, Tubeless Ready  
**FRONT HUB** #Shimano HB-MT400-B, 15mm, Boost, Centerlock  
**REAR HUB** #Shimano FH-MT400-B, 12mm, Boost, Centerlock  
**TYRES** #Schwalbe Smart Sam, Active, 2.60  
**PEDALS** #CUBE PP MTB  
**SADDLE** #Natural Fit Sequence  
**SEAT POST** #CUBE Performance Post, 30.9mm  
**SEATCLAMP** #CUBE Varioclose Semi Integrated, 34.9mm

**SPARE PARTS**

- 8000** CUBE Headset Orbit Z 1.5E ZS
- 8528** CUBE BEARING\_pivot set-Ø15x87.4 (18-02089)
- 8529** CUBE AXLE\_pivot set-shock mount (18-02849)
- 8539** CUBE BEARING\_pivot set-Ø10x23,5
- 8540** CUBE BEARING\_pivot set-horst link
- 8651** CUBE HANGER\_mtb-x12-std-2020 (18-05516)

**WEIGHT** #4,9 kg

FULLSUSPENSION





# STEREO HYBRID 120 PRO ALLROAD 29

black'n'red



One bike, all reasons: an impossible ask? Not when you've got the CUBE design team on the case. The brand-new Stereo Hybrid 120 Pro Allroad is quite possibly one of the most versatile bikes we've ever created – a comfortable, fully equipped Bosch e-bike with the benefits of our acclaimed four-bar suspension, components specially picked for their off-road ability, and accessories that mean it can tackle just about any job on two wheels you care to throw its way. The included mudguards help keep spray at bay when the weather's bad, whilst the luggage carrier allows you to tackle your daily commute or bring extra luggage with you for an extended weekend tour. We even added a bell, kickstand and front and rear lights powered from the Bosch battery. As for the rest of the bike, it's unadulterated CUBE perfection. The CUBE Modular Battery System tucks the power unit neatly away out of sight in the down tube, safe from dirt and water ingress but easily accessible thanks to a push-button cover with a hidden lock. It also gave our engineers the extra space they needed to offer the option of an even more powerful battery, for extended range. The Boost 148 rear end and 1.5in head tube provide the stiff, accurate platform needed to deliver the brand-new Bosch drive unit's smooth, quiet torque to the rear wheel, and our Agile Comfort Geometry works seamlessly with the RockShox Deluxe Select shock and Judy Silver air fork to smooth out the trail and put you in full control, at all times. Sram's SX Eagle 12-speed transmission offers an incredible range of gears to put any hill within easy reach, while powerful Shimano hydraulic disc brakes and wide, comfortable Schwalbe tyres serve up epic quantities of grip. If there's a journey on two wheels that can't be tackled by the Stereo Hybrid 120 Pro, we can't think of it.

- ★ **335102** Cube Stereo Hybrid 120 Pro 625 Allroad 29 black'n'red 2020
- ★ **335101** Cube Stereo Hybrid 120 Pro 500 Allroad 29 black'n'red 2020

**FRAME** Aluminum Superlite, Gravity Casting Technology, Efficient Comfort Control, FSP 4-Link, Agile Comfort Geometry, Boost 148, Full Integrated Battery, Kickstand/Fender/Carrier Mounting Points  
**SIZE** #6", 18", 20", 22"  
**FORK** RockShox Recon RL Air, Tapered, 15x110mm, eMTB Approved, 120mm  
**SHOCK** RockShox Deluxe Select, 185x55mm, Rebound Adjust, Trunnion Mount  
**SHOCK HARDWARE** #top: 54mm Trunnion Mount, Bottom: 30x8mm

**DRIVE UNIT** Bosch Drive Unit Performance CX Generation 4 (75Nm) Cruise (250Watt)  
**BATTERY** Bosch PowerTube 625  
**DISPLAY** Bosch Kiox  
**CHARGER** Bosch 2A

**HEADSET** #SA Orbit Z 1.5B ZS, Top Zero-Stack 1 1/2" (OD 56mm), Bottom Zero-Stack 1 1/2" (OD 56mm)  
**STEM** CUBE Performance Stem E-MTB, 31.8mm  
**HANDLEBAR** #Newmen Evolution SL 318.25, 760mm  
**GRIPS** #Natural Fit All Terrain  
**REAR DERAILLEUR** #Sram SX Eagle™, 12-Speed  
**SHIFTERS** #Sram SX Eagle™ Trigger, Single Click  
**BRAKE SYSTEM** #Shimano BR-MT420/MT400, Hydr. Disc Brake (203/180)  
**CRANKSET** #CID E-Crank, 38T, 170mm  
**CASSETTE** #Sram PG-1210 Eagle™, 11-50T  
**CHAIN** #Sram SX Eagle™  
**RIMS** #CUBE EX30, 32H, Disc, Tubeless Ready  
**FRONT HUB** #Shimano HB-MT400-B, 15mm, Boost, Centerlock  
**REAR HUB** #Shimano FH-MT400-B, 12mm, Boost, Centerlock  
**TYRES** #Schwalbe Smart Sam, Active, 2.35  
**PEDALS** #CUBE PP MTB  
**SADDLE** #Natural Fit Sequence  
**SEAT POST** #CUBE Performance Post, 30.9mm  
**SEATCLAMP** #CUBE Varioclose Semi Integrated, 34.9mm  
**FRONT LIGHT** #ezyne Power E115, X-Lock Mount, 6-12V, DC  
**REAR LIGHT** #Busch&Müller Xeltec, DC  
**KICKSTAND** #CUBEstand Pro, Adjustable  
**MUDGUARDS** #ACID 75  
**BELL** #nog 0i  
**CARRIER** #CID Semi-Integrated Carrier, ACID RILink Adapter Compatible

**SPARE PARTS**  
**8000** CUBE Headset Orbit Z 1.5E ZS  
**8528** CUBE BEARING\_pivot set-Ø15x87.4 (18-02089)  
**8529** CUBE AXLE\_pivot set-shock mount (18-02849)  
**8539** CUBE BEARING\_pivot set-Ø10x23,5  
**8540** CUBE BEARING\_pivot set-horst link  
**8651** CUBE HANGER\_mtb-x12-std-2020 (18-05516)

**WEIGHT** #6,3 kg



**93111**  
ACID PANNIERS TRAVLR 15



**11967**  
ACID GLOVES WS X NF



**93115**  
ACID PANNIERS TRAVLR FRONT 6 FILINK

FULLSUSPENSION

# ROAD RACE

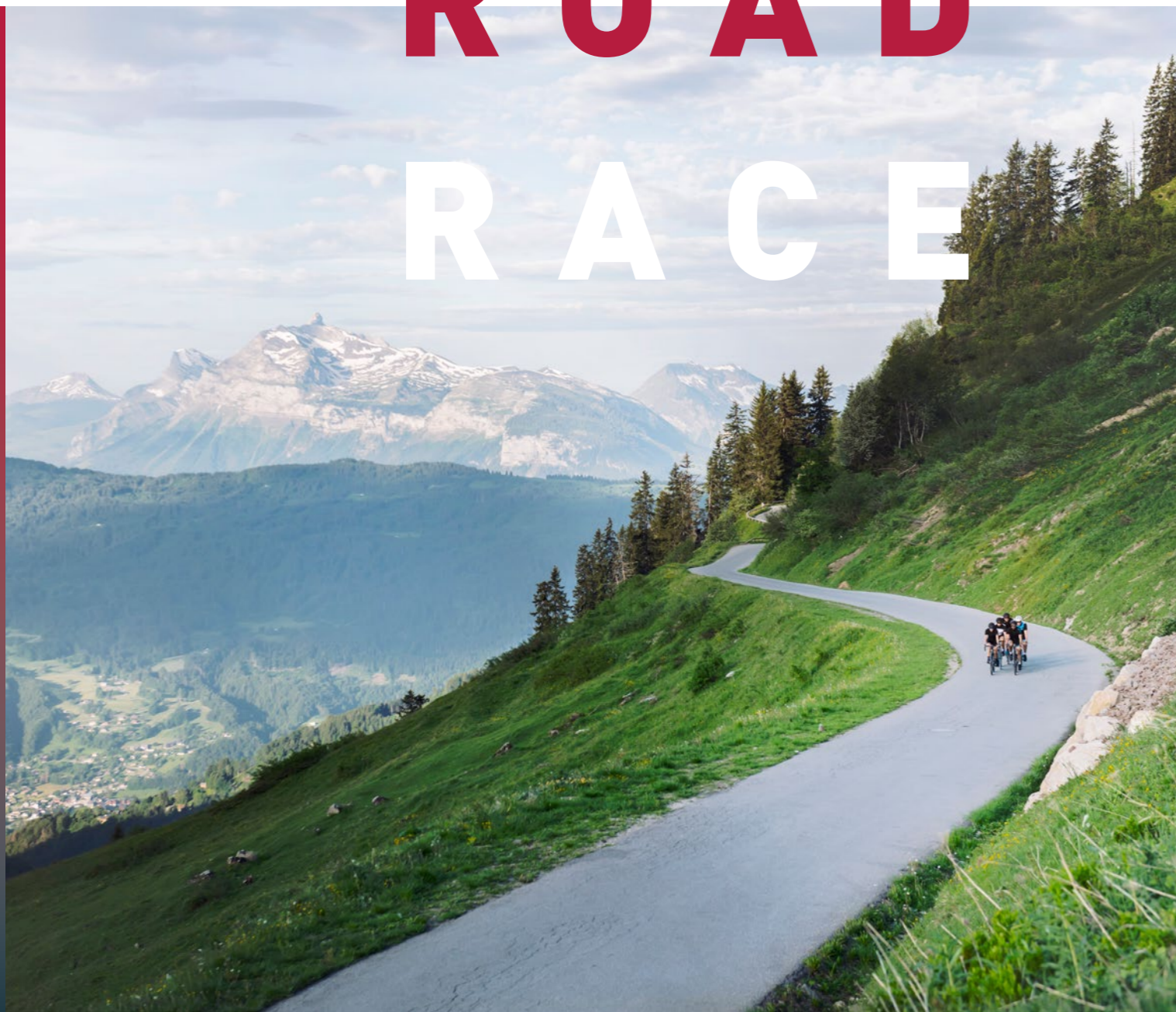

146 **AGREE** C:62

156 **NUROAD** C:62

COMFORT

COMFORT

ENDURANCE

ENDURANCE



**AGREE**

Refined elegance meets restrained power. The Agree Hybrid isn't just a new road bike, it's a new kind of road bike. With a fully removable, completely self-contained pedal assist drive unit and design inspired by its pure-bred forerunners, it's a bike that will expand your range... and open your eyes.

**NUROAD**

The road ahead isn't always smooth. Luckily, we've thought of that. The new, Fazua-powered Nuroad Hybrid rolls where other road bikes fear to go, harnessing the power of its clever, removable drive system to comfortable Cube geometry. Go explore.

# FOR us #Roadies

It's not particularly tricky to attach a battery pack and a motor to a bike these days, if you don't care about looks. But our engineers are always looking to make things better – and, to them, the idea of an ugly road bike was simply anathema. So the Agree Hybrid C:62 represented a very particular challenge: combine the elegant simplicity of a road race machine with the incredible performance potential of a pedal-assist e-bike system. Using our premium C:62 carbon and Advanced Twin Mold construction technique, they succeeded in fully enclosing the drive unit and battery in an elegant down tube, so most people won't even notice you're riding an e-bike. Thru axles front and rear and a carbon bladed fork with tapered steerer contribute to a torsionally rigid structure, so pedal response is instantaneous and steering is accurate and intuitive. And of course, we routed cables internally to match the frame's clean looks and reduce the need for maintenance. Because once you've tried the Agree Hybrid C:62, there's only thing you'll want to do: ride. And then ride some more.



ROAD RACE



# FAZUA TECHNOLOGY

UNDERSTANDING FAZUA.



FAZUA was founded in 2013 in Munich, Germany. Since then, the Bavarians have followed their goal of revolutionizing the E-Bike market. The team around the CEOs Johannes Biechele and Fabian Reuter presents an innovative e-Bike drive system directed towards sportive demands and, at the same time, creating a natural feeling of non-motorized bike riding. The unique, slim design and light weight of just 3,3 kg combines motor, battery and electronics in one drivepack. Therefore, bike manufactures can create frames that integrate the drivepack elegantly and discreetly within the down tube.

Another special feature of the evation drive system is that the engine and the bottom bracket are completely separated from each other at a speed of 25 km/h and above. In addition to the inconspicuous frame integration and the light weight of the drive unit, it is especially for E-Bikes unusually natural and dynamic driving feeling, which makes the evation drive so unique.



## evation

THE LIGHTEST AND MOST COMPACT DRIVE SYSTEM IN ITS FIELD

### BOTTOM BRACKET

Both-sided Torque and cadence measurement

**1,31 kg** 60 Nm

### DRIVEPACK

Removable motor unit

**1,92 kg** 250 W

### BATTERY

Replaceable Li-ion battery pack

**1,38 kg** 250 W 36 V

### REMOTE

Three support modes

BREEZE  
RIVER  
ROCKET  
MODE up to 400 W



At just 4.6 kg evation is the lightest and most compact drive system in its class. Due to this the enjoyment of riding and the dynamism of a bicycle without a motor.



Thanks to the innovative design and the technology behind it, the drive system can be integrated easily into the down tube. Therefore, the E-Bike, at first glance, looks like an ordinary bicycle.



FAZUA combines the natural driving joy of cycling with the advantages of an E-Bike: Through the double-sided torque and cadence measurement in the bottom bracket, the system adapts completely to its driver. If you pedal strongly and bring a lot of force on the cranks, you will be strongly supported, too.



The engine switches off at 25 km/h. The integrated freewheel is designed in that manner that you can reach top speeds on your own without unnatural resistance. As soon as you fall below the 25 km/h limit the system will support you again.



With just one push on the remote button, the system can be deactivated. Without any unnatural resistance, the E-Bike now behaves like a non-motorised bike. The drivepack can be added and removed with one click and allows a quick switch from a bike to a pedelec whenever you like.

# AGREE HYBRID C:62 SLT

black edition

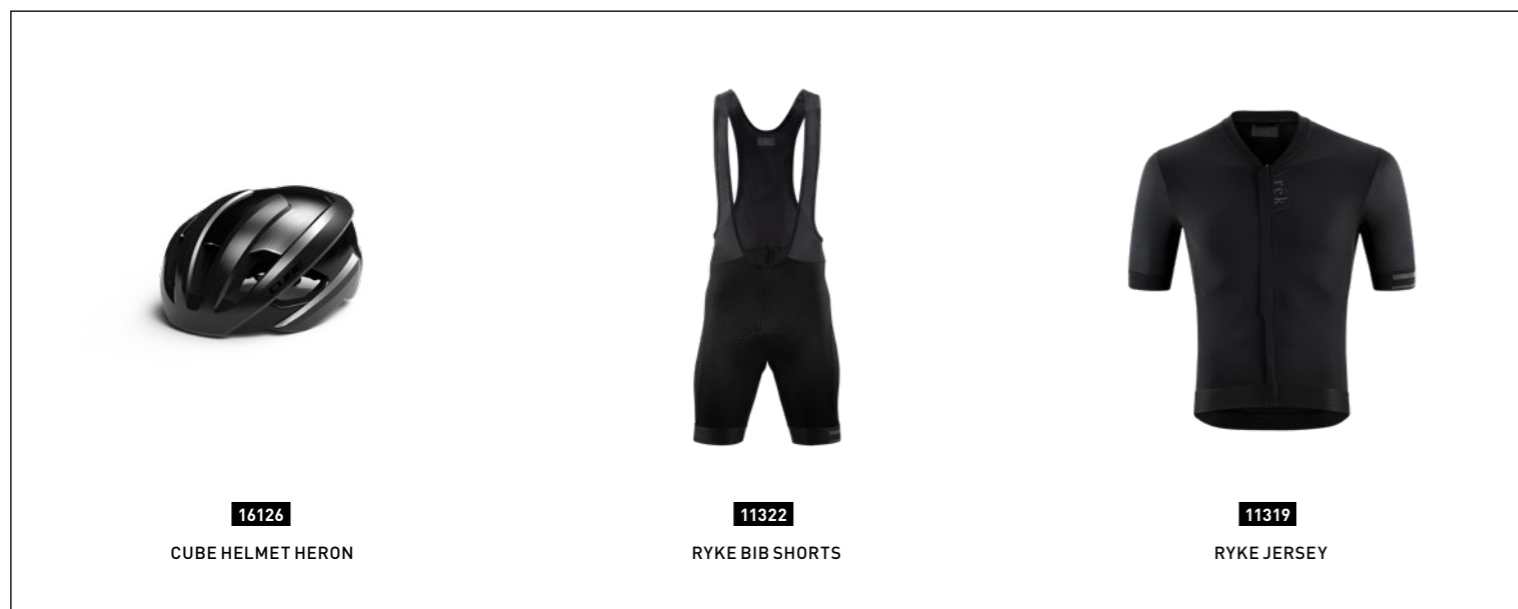

16126  
CUBE HELMET HERON

11322  
RYKE BIB SHORTS

11319  
RYKE JERSEY

There's a lot to be said for not messing with a successful formula. That's why, when we set out to design our standard-setting Agree Hybrid C:62 SLT road e-bike, we wanted to pay homage to road riding's long history of elegant, form-follows-function design. By enclosing the sophisticated, removable Fazua drive unit and battery entirely within the down tube, our engineering team succeeded in creating a stiff and strong backbone – but, just as importantly, one that also looks stunning. With clearance for tyres up to 35mm and the reassurance of Shimano's powerful DuraAce hydraulic disc brakes and their all-weather stopping ability, it's a nimble and powerful companion that'll redefine your expectations of road biking. Shimano's electronic DuraAce Di2 transmission, with completely concealed cables, works seamlessly with the Fazua drive system to deliver incredibly smooth gear shifts and quiet, smooth pedal assistance. Almost effortless climbing and extended range are just two of the benefits – and if you decide you'd prefer to ride without assistance, the drive system is completely removable. A carbon fork, Newmen cockpit components and wheels and Natural Fit saddle round out a remarkable package of wish-list components. Part technological masterpiece, part object of desire... and a new classic to add to the pantheon of beautiful road bikes.

★ 339150 Cube Agree Hybrid C:62 SLT black edition 2020

FRAME# C:62 Advanced Twin Mold Technology Aero Frame, Flat Mount Disc, Road Comfort Geometry, AXH, 12x142mm  
 SIZE# 3, 56, 59  
 FORK# CUBE CSL Evo Aero C:62 Technology, 1 1/8" / 1 1/2" Tapered, Flat Mount, 12x100mm

DRIVE UNIT# Evation 1.0 Drive Pack, 60Nm, 250Watt  
 BATTERY# Evation 1.0 Battery, 250Wh  
 DISPLAY# Evation 1.0 Integrated Touch Remote  
 CHARGER# Evation 1.0 Charger

HEADSET# FSA I-t, Top Integrated 1 1/8", Bottom Integrated 1 1/2"  
 STEM# Newmen Evolution 318.4, 31.8mm  
 HANDLEBAR# Newmen Advanced Wing Bar, Carbon  
 HANDLEBAR TAPE# CUBE Grip Control  
 REAR DERAILLEUR# Shimano Dura Ace Di2 RD-R9150-DSS, 11-Speed  
 FRONT DERAILLEUR# Shimano Dura Ace Di2 FD-R9150-F, Braze-On  
 SHIFT/ BRAKE LEVERS# Shimano Dura Ace Di2 ST-R9170  
 BRAKE SYSTEM# Shimano Dura Ace BR-R9170, Hydr. Disc Brake, Flat Mount [160/160]  
 CRANKSET# FSA CK-8685 Carbon, 50x34T  
 CASSETTE# Shimano Dura Ace CS-R9100, 11-28T  
 CHAIN# Shimano CN-HG900-11  
 WHEELSET# Newmen Advanced SL R.38 Carbon, 12x100mm / 12x142mm, Tubeless Ready  
 TYRES# Schwalbe Pro One, Tubeless Easy, 30-622  
 SADDLE# Natural Fit Nuance SLT Road  
 SEAT POST# Newmen Advanced SL, Carbon, 27.2mm  
 SEATCLAMP# CUBE Aero, Semi-Integrated

WEIGHT# 2,5 kg

SPARE PARTS#  
 10063 CUBE Hanger Attain/Agree/Cross Race/Gravel  
 10360 CUBE Headset FSA I-t, Top Integrated 1 1/8", Bottom Integrated 1 1/4"

# AGREE HYBRID C:62 SL

carbon'n'red

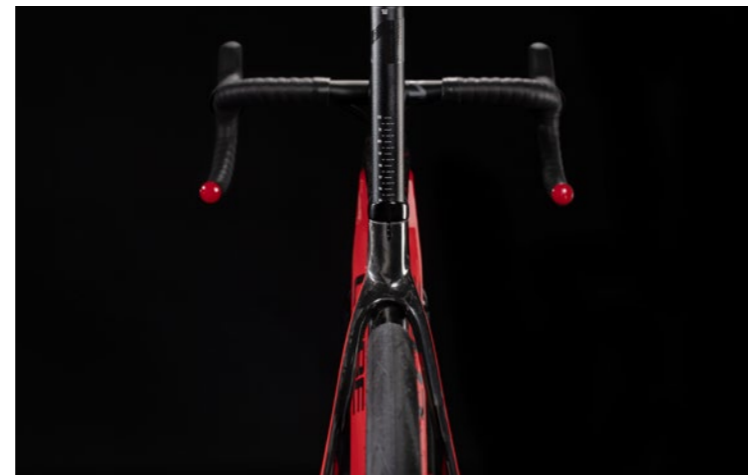

**11012**  
CUBE BLACKLINE JERSEY



**11015**  
CUBE BLACKLINE BIB SHORTS



**16129**  
CUBE HELMET HERON

The Agree Hybrid C:62 SL ushers in a quiet revolution in road riding. Blending the elegance and simplicity of classic road bike design with the versatility and adaptability of an advanced pedal-assist drive system, it opens up new frontiers for any rider. Tackle any climb, ride further or ride more... it's all there for the taking. Concealed inside the sleek carbon frame is the unique – and removable – Fazua drive unit and battery. Completely self-contained, it works seamlessly with Shimano's Ultegra 2x11 gears to deliver smooth additional power to the rear wheel. The minimalist frame design hides the extraordinary amount of work undertaken by our engineering team to realise the dream of race bike aesthetics and performance with e-bike power. Borrowing heavily from their experience building some of the fastest road bikes on the planet on the one hand, and some of the best e-bikes on the other, they used proprietary CUBE technologies like our C:62 carbon and Advanced Twin Mold manufacturing to build a light, stiff and responsive frame that's so stunning to look at, most people will never guess you're riding an e-bike. With powerful hydraulic disc brakes for dependable all-weather stopping, it's a bike that'll redefine your expectations of what's possible on an e-bike. Where will it take you next?

- ★ **339050** Cube Agree Hybrid C:62 SL carbon'n'red 2020

---

- 🔍 **FRAME** #C:62 Advanced Twin Mold Technology Aero Frame, Flat Mount Disc, Road Comfort Geometry, AXH, 12x142mm  
**SIZE** #3, 56, 59  
**FORK** #CUBE CSL Evo Aero C:62 Technology, 1 1/8" / 1 1/2" Tapered, Flat Mount, 12x100mm

---

- 🔋 **DRIVE UNIT** #Evation 1.0 Drive Pack, 60Nm, 250Watt  
**BATTERY** #Evation 1.0 Battery, 250Wh  
**DISPLAY** #Evation 1.0 Integrated Touch Remote  
**CHARGER** #Evation 1.0 Charger

---

- 🔧 **HEADSET** #SA I-t, Top Integrated 1 1/8", Bottom Integrated 1 1/2"  
**STEM** #Newmen Evolution 318.4, 31.8mm  
**HANDLEBAR** #Newmen Evolution Wing Bar  
**HANDLEBAR TAPE** #CUBE Grip Control  
**REAR DERAILLEUR** #Shimano Ultegra RD-R8000-DGS, 11-Speed  
**FRONT DERAILLEUR** #Shimano Ultegra FD-R8000-F  
**SHIFT/ BRAKE LEVERS** #Shimano Ultegra ST-R8020  
**BRAKE SYSTEM** #Shimano Ultegra BR-R8070, Hydr. Disc Brake, Flat Mount (160/160)  
**CRANKSET** #SA CK-8685 Carbon, 50x34T  
**CASSETTE** #Shimano CS-R7000, 11-32T  
**CHAIN** #Shimano CN-HG601  
**WHEELSET** #Newmen Evolution SL R.32, 12x100mm / 12x142mm, Tubeless Ready  
**TYRES** #Schwalbe Pro One, Tubeless Easy, 30-622  
**SADDLE** #elle Royal Asphalt  
**SEAT POST** #Newmen Evolution, 27.2mm  
**SEATCLAMP** #CUBE Aero, Semi-Integrated

---

- 📦 **WEIGHT** #3,4 kg

- 🔧 **SPARE PARTS**
- 10063** CUBE Hanger Attain/Agree/Cross Race/Gravel
- 10360** CUBE Headset FSA I-t, Top Integrated 1 1/8", Bottom Integrated 1 1/4"

ROAD RACE

# AGREE HYBRID C:62 RACE

carbon 'n' white



Sometimes you'll find a surprise hiding within plain sight. Take a really close look at the Agree Hybrid C:62 Race, because it's not quite what it seems. Sure, it's an elegant, carbon-framed road bike in the tradition of elegant, carbon-framed road bikes. But it's also a technical marvel – a sophisticated e-bike that represents an entirely new way to ride on the road. Because, concealed in that sculpted down tube is a secret – an entirely self-contained, removable Fazua drive unit and 250Wh battery. Working seamlessly with Shimano's iconic 105 2x11 transmission, it's capable of extending your range, flattening out the climbs and opening up a whole world of new riding possibilities. Our premium C:62 carbon and Advanced Twin Mold construction enabled our engineers to create this miracle of clever packaging, while front and rear thru axles and a carbon bladed fork with tapered steerer contribute to a torsionally rigid structure, so pedal response is instantaneous and steering is accurate and intuitive. Shimano 105 hydraulic disc brakes with Continental Grand Sport Race SL tyres put you in full control on even the longest descents, and a comfortable Selle Royal saddle rounds out a package that combines value with completely dependable performance. Open your eyes, take a leap of faith and see what possibilities the open road brings...

★ **339040** Cube Agree Hybrid C:62 Race carbon 'n' white 2020

**FRAME** #62 Advanced Twin Mold Technology Aero Frame, Flat Mount Disc, Road Comfort Geometry, AXH, 12x142mm  
**SIZE** #3, 56, 59  
**FORK** #CUBE Agree Hybrid C:62 Race, One Piece 3D-Forged Steerer/Crown, Carbon Blades, 1 1/8" - 1 1/2" Tapered, Flat Mount, 12x100mm

**DRIVE UNIT** #evation 1.0 Drive Pack, 60Nm, 250Watt  
**BATTERY** #evation 1.0 Battery, 250Wh  
**DISPLAY** #evation 1.0 Remote, 31.8mm Road Bar Clamp  
**CHARGER** #evation 1.0 Charger

**HEADSET** #SA I-t, Top Integrated 1 1/8", Bottom Integrated 1 1/2"  
**STEM** #CUBE Performance Stem Pro, 31.8mm  
**HANDLEBAR** #CUBE Gravel Race Bar  
**HANDLEBAR TAPE** #CUBE Grip Control  
**REAR DERAILLEUR** #shimano 105 RD-R7000-DGS, 11-Speed  
**FRONT DERAILLEUR** #shimano 105 FD-R7000-FL  
**SHIFT/ BRAKE LEVERS** #shimano 105 ST-R7020  
**BRAKE SYSTEM** #shimano 105 BR-R7070, Hydr. Disc Brake, Flat Mount [160/160]  
**CRANKSET** #SA CK-746 Alloy, 50x34T  
**CASSETTE** #shimano CS-R7000, 11-32T  
**CHAIN** #shimano CN-HG601  
**WHEELSET** #CUBE RA 0.8 Aero Disc, 100x12mm / 142x12mm  
**TYRES** #conti Grand Sport Race SL, 28-622  
**SADDLE** #selle Royal Asphalt  
**SEAT POST** #CUBE Performance Post, 27.2mm  
**SEATCLAMP** #CUBE Aero, Semi-Integrated

**WEIGHT** #4,9 kg

**SPARE PARTS#**  
**10063** CUBE Hanger Attain/Agree/Cross Race/Gravel  
**10360** CUBE Headset FSA I-t, Top Integrated 1 1/8", Bottom Integrated 1 1/4"



**11011**  
CUBE BLACKLINE JERSEY



**11016**  
CUBE BLACKLINE BIB SHORTS 3/4



**17099**  
CUBE SHOES RD SYDRIX PRO

# FOR us #Offroaders

There's something to be said for not messing with a successful formula. That's why, when we set out to design a standard-setting hybrid gravel bike, we wanted to pay homage to road and cyclocross riding's long history of elegant, form-follows-function design. By enclosing the sophisticated Fazua drive unit and battery entirely within the down tube, our engineering team created a stiff and strong backbone for the Nuroad Hybrid C:62 but, just as importantly, one that also looks stunning. Our premium C:62 carbon and Advanced Twin Mold construction technique combine to create a frame that's surprisingly light, extremely responsive – thanks partly to 12mm thru axles front and rear – and superbly comfortable. The carbon fork and geometry tailored for comfort mean that you'll feel right at home, even on the longest rides, and we built in enough clearance for tyres up to 35mm so you can choose the right tyres for the job. Redefine your expectations of what a gravel bike can be, then go out and ride routes that you never thought possible...



ROAD RACE



# NUROAD HYBRID C:62 SL

blue'n'blue



Never stop exploring. With the Nuroad Hybrid C:62 SL, you'll be able to extend your road tours further than ever before. Ride for longer, ride more climbs, keep going when the road ends... it's the kind of e-bike that'll completely redefine your expectations. Blending the exceptional performance and sleek good looks of a frame constructed from our premium C:62 carbon with the smooth power delivery of Fazua's drive unit and 250Wh battery, it offers a revelatory ride experience. With access to our Advanced Twin Mold manufacturing technique – and the benefit of years of experience producing some of the best e-bikes in the world – our engineering team managed to enclose the removable drive unit and battery completely within the Nuroad Hybrid C:62 SL's elegant down tube. Combined with a wide-ranging Shimano 1x11 transmission, it means you'll experience easier climbs and extended range like never before. And, if you'd rather ride without e-assistance, it's simple to remove the drive unit and battery. Wide 35mm tyres, full-length mudguards and a dynamo-driven front and rear lighting system ensure you're equipped for long days out in the hills, while Shimano's gravel-specific GRX hydraulic disc brakes give you powerful all-weather stopping to keep you safely in control at all times. Big days out in big country just got bigger, with no extra effort. Isn't that a win/win?

★ **339200** Cube Nuroad Hybrid C:62 SL blue'n'blue 2020

**FRAME** #C:62 Advanced Twin Mold Technology Aero Frame, Flat Mount Disc, Road Comfort Geometry, AXH, 12x142mm  
**SIZE** #3, 56, 59  
**FORK** #CUBE Nuroad Disc, One Piece 3D-Forged Steerer/Crown, Carbon Blades, 1 1/8" - 1 1/2" Tapered, Flat Mount, 12x100mm

**DRIVE UNIT** #evation 1.0 Drive Pack, 60Nm, 250Watt  
**BATTERY** #evation 1.0 Battery, 250Wh  
**DISPLAY** #evation 1.0 Integrated Touch Remote  
**CHARGER** #evation 1.0 Charger

**HEADSET** #SA I-t, Top Integrated 1 1/8", Bottom Integrated 1 1/2"  
**STEM** #CUBE Performance Stem Pro, 31.8mm  
**HANDLEBAR** #CUBE Gravel Race Bar  
**HANDLEBAR TAPE** #CUBE Grip Control  
**REAR DERAILLEUR** #shimano GRX RD-RX812D, 11-Speed  
**SHIFT/ BRAKE LEVERS** #shimano GRX ST-RX810  
**BRAKE SYSTEM** #shimano GRX BR-RX810, Hydr. Disc Brake (160/160)  
**CRANKSET** #SA CK-746 Alloy, 40T  
**CASSETTE** #shimano SLX CS-M7000, 10-42T  
**CHAIN** #shimano CN-HG601  
**WHEELSET** #CUBE RA 0.8 CX, 100x12mm / 142x12mm  
**TYRES** #schwabe G-One Speed, Performance, Kevlar, 35-622  
**SADDLE** #Natural Fit Nuance Lite  
**SEAT POST** #Newmen Evolution, 27.2mm  
**SEATCLAMP** #CUBE Aero, Semi-Integrated  
**FRONT LIGHT** #supernova E3 Pure 3  
**REAR LIGHT** #CID Pro D-Rear Mudguard  
**MUDGUARDS** #CID 45  
**BELL** #knog Oi

**WEIGHT** #5,8 kg

**SPARE PARTS#**  
**10063** CUBE Hanger Attain/Agree/Cross Race/Gravel  
**10360** CUBE Headset FSA I-t, Top Integrated 1 1/8", Bottom Integrated 1 1/4"



**11155**  
CUBE BLACKLINE JERSEY 2020



**93109**  
CUBE FAHRRADTASCHE FRAMEBAG 4



**11335**  
CUBE RACE CAP ZICK ZACK

W  
E  
S  
I  
  
O  
N  
E  
E  
  
M  
S  
R  
S



162 ACCESS HPA | 27.5, 29

COMFORT  
COMFORT  
  
TOUR  
TOUR  
  
SPORT  
SPORT



ACCESS

Take the path less travelled – with the new Access Hybrid, you can go your own way. Sleek, agile and with the equipment you need to tackle any trail, it's the fourth generation Bosch e-bike that's been missing from your off-road adventures. Ride further, faster and more adventurously.

---

## FOR us #Women

---

Never stand still for too long. It's a pretty good approach to take in life, and it also happens to be one that you could apply to our frame designers. The brand-new Access Hybrid 29 is the result of their never-ending quest for perfection – a fourth-generation Bosch-powered e-MTB that builds on all our experience to make a better handling, easier to live with bike. With a design centred around our new Modular Battery System, its sleek looks are down to the fact that the Bosch power unit lives entirely inside the down tube under a protective, easily accessed cover. The new design frees up enough space for a bottle cage mount and the option of a higher capacity battery, so you can extend your rides even further. The smooth, powerful Bosch motor boosts your pedalling via an intentionally rigid frame design that encompasses a 12mm Boost rear axle, oversized chain stays and a 1.5in head tube – all features designed to ensure efficient power delivery, accurate steering and rock-steady handling. We've designed it around the needs of a 120mm fork – so you've plenty of suspension travel to smooth out the trail ahead – and internal cable routing even includes provision for a stealth dropper post upgrade. And the best news of all? We've designed all this sophisticated frame wizardry in both standard and trapeze options, so that every woman can find the perfect Access Hybrid 29 for her own needs. What's stopping you?





You've earned your stripes. You've sweated the climbs, owned the descents and racked up the miles. It's time to treat yourself to the best. The new Access Hybrid SLT encompasses everything we've learnt about building light, great handling 29er hardtails for women... and adds the power of Bosch's superb fourth-generation CX drive system, the range of an extra-large-capacity battery and the reliability of a stunning selection of premium components. Starting with a blank sheet of paper, our engineers began by creating the innovative Modular Battery System, which houses the Bosch power unit securely inside the frame's down tube under an easily accessed cover. They added a custom housing for the Bosch drive unit, then focussed on making the frame as efficient and agile as possible. Oversized chain stays, a Boost 148 rear axle and 1.5in head tube help transfer every watt of your pedalling – and the Bosch motor's assistance – to the rear wheel via Shimano's superb SLX and XT 12-speed transmission. Gear shifts are instantaneous and smooth – and they'll stay that way, thanks to internal cable routing that also allows for a quick and easy upgrade to a stealth dropper post, so you can seek out those borderline unrideable lines, if you like. Big-volume, smooth-rolling Schwalbe Smart Sam tyres work with the smooth, easily configurable Fox 34 Rhythm fork to help keep the rubber side down – and we included Shimano's strong, powerful hydraulic disc brakes to ensure you're always in control, even on the fastest or steepest descents. So go ahead – you've earned this. There's no better Bosch e-bike hardtail for women, and no better way of expanding your trail-riding horizons.

★ **338352** Cube Access Hybrid SLT 625 29 iridium'n' deepred 2020

**FRAME** Aluminium Superlite, Gravity Casting, Agile Ride Geometry, 1.5 Headtube, Boost 148, Internal Cable Routing, Full Integrated Battery, Kickstand/Fender/Carrier Mounting Points  
**SIZE** #5", 17", 19"  
**FORK** Fox 34 Rhythm, 2-Position Sweep-Adjust GRIP Damper, Tapered, 15x110mm, E-Bike Optimized, 120mm

**DRIVE UNIT** Bosch Drive Unit Performance CX Generation 4 (75Nm) Cruise (250Watt)  
**BATTERY** Bosch PowerTube 625  
**DISPLAY** Bosch Kiox  
**CHARGER** Bosch 4A

**HEADSET** #SA Orbit Z 1.5E ZS, Top Zero-Stack 1 1/2" (OD 56mm), Bottom Zero-Stack 1 1/2" (OD 56mm)  
**STEM** #CUBE Performance Stem, 31.8mm  
**HANDLEBAR** #Newmen Evolution 318.10, 720mm  
**GRIPS** #Natural Fit All Terrain  
**REAR DERAILLEUR** #Shimano XT RD-M8100-SGS, ShadowPlus, 12-Speed  
**SHIFTERS** #Shimano SLX SL-M7100-I Direct Attach  
**BRAKE SYSTEM** #Shimano XT BR-M8120, Hydr, Disc Brake (203/180)  
**CRANKSET** #thirteen Plus Crank, 38T, 170mm  
**CASSETTE** #Shimano SLX CS-M7100, 10-51T  
**CHAIN** #Shimano SLX CN-M7100  
**RIMS** #CUBE EX30, 32H, Disc, Tubeless Ready  
**FRONT HUB** #Shimano HB-MT400-B, 15mm, Boost, Centerlock  
**REAR HUB** #Shimano FH-MT510-B, 12mm, Boost, Centerlock  
**TYRES** #Schwalbe Smart Sam, Performance, Kevlar, 2.60  
**PEDALS** #CUBE PP MTB  
**SADDLE** #Natural Fit Sequence+ WS  
**SEAT POST** #CUBE Performance Post, 30.9mm  
**SEATCLAMP** #CUBE Varioclose, 34.9mm

**WEIGHT** #2,8 kg

**SPARE PARTS**  
**8000** CUBE Headset Orbit Z 1.5E ZS  
**8651** CUBE HANGER\_mtb-x12-std-2020 (18-05516)

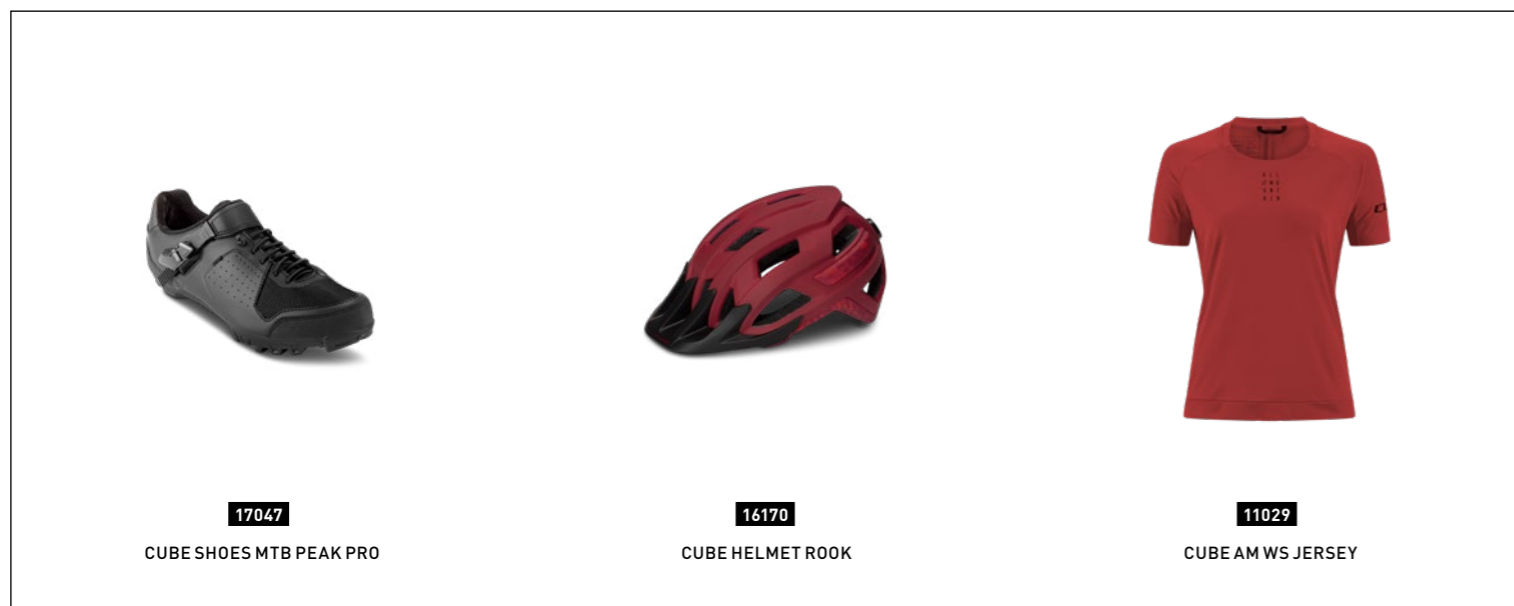

**17047**  
CUBE SHOES MTB PEAK PRO

**16170**  
CUBE HELMET ROOK

**11029**  
CUBE AM WS JERSEY

# ACCESS HYBRID SL 29

black 'n' green



# ACCESS HYBRID SL 29

blue 'n' coral



Trapeze | black 'n' green



Trapeze | blue 'n' coral



Ready to explore a bit further and experience a bit more? In that case you'll be needing a Bosch e-bike that'll help you push your limits. The new Access Hybrid SL's powerful, fourth-generation Bosch drive unit will match your every pedal stroke with a dose of extra power and torque – and fast-rolling 29er wheels with a 120mm travel fork and the incredible gear range of Sram's NX Eagle 12-speed transmission will help you make light work of any trail. We even found room to include a high-capacity battery that offers more range than before, thanks to an innovative new frame design that incorporates our Modular Battery System. Hidden in the sleek down tube under an easily accessed cover, the powerful Bosch power unit is your ticket to extended days out on your favourite trails and long days exploring new routes. Integrated cable routing complements the frame's Smooth Welding and sleek appearance, whilst reducing maintenance down-time and also allowing for an easy stealth dropper post upgrade for those sketchy line choices. We tailored cockpit components like the stem, handlebar and saddle to the female anatomy, and there's even a trapeze frame option – so every woman can find her perfect fit. Magura MT Fifty four-piston hydraulic disc brakes work with the Schwalbe 2.6in tyres to keep you firmly in control at all times, even when the smooth and easily adjustable RockShox Recon air fork's 120mm of travel helps you nudge the edge of your comfort zone on the descents. Because, really, that's what it's all about. Live life to the full, ride further, push your limits. The Access Hybrid SL is your best friend on your journey to new trails and new experiences...

- ★ **338312** Cube Access Hybrid SL 625 29 blue 'n' coral 2020
- ★ **338302** Cube Access Hybrid SL 625 29 black 'n' green 2020

**FRAME** Aluminium Superlite, Gravity Casting, Agile Ride Geometry, 1.5 Headtube, Boost 148, Internal Cable Routing, Full Integrated Battery, Kickstand/Fender/Carrier Mounting Points  
**SIZE** #5", 17", 19", Trapeze: 15", 17", 19"  
**FORK** #RockShox Recon RL Air, Tapered, 15x110mm, eMTB Approved, 120mm

**DRIVE UNIT** #Bosch Drive Unit Performance CX Generation 4 (75Nm) Cruise (250Watt)  
**BATTERY** #Bosch PowerTube 625  
**DISPLAY** #Bosch Kiox  
**CHARGER** #Bosch 2A

**HEADSET** #SA Orbit Z 1.5E ZS, Top Zero-Stack 1 1/2" [OD 56mm], Bottom Zero-Stack 1 1/2" [OD 56mm]  
**STEM** #CUBE Performance Stem, 31.8mm  
**HANDLEBAR** #Newmen Evolution 318.10, 720mm  
**GRIPS** #Natural Fit All Terrain  
**REAR DERAILLEUR** #Sram NX Eagle™, 12-Speed  
**SHIFTERS** #Sram NX Eagle™ Trigger, Single Click  
**BRAKE SYSTEM** #Magura MT Fifty, Hydr. Disc Brake (203/180)  
**CRANKSET** #CID E-Crank, 38T, 170mm  
**CASSETTE** #Sram PG-1210 Eagle™, 11-50T  
**CHAIN** #Sram SX Eagle™  
**RIMS** #CUBE EX30, 32H, Disc, Tubeless Ready  
**FRONT HUB** #Shimano HB-MT400-B, 15mm, Boost, Centerlock  
**REAR HUB** #Shimano FH-MT400-B, 12mm, Boost, Centerlock  
**TYRES** #Schwalbe Smart Sam, Active, 2.60  
**PEDALS** #CUBE PP MTB  
**SADDLE** #Natural Fit Sequence+ WS  
**SEAT POST** #CUBE Performance Post, 30.9mm  
**SEATCLAMP** #CUBE Varioclose, 34.9mm

**WEIGHT** #2,9 kg

**SPARE PARTS**  
**8000** CUBE Headset Orbit Z 1.5E ZS  
**8651** CUBE HANGER\_mtb-x12-std-2020 [18-05516]



10719

CUBE AM WS JERSEY



10700

CUBE AM WS BAGGY SHORTS



10779

CUBE AM WS JERSEY

# ACCESS HYBRID EXC 29

iridium 'n' hazypurple



# ACCESS HYBRID EXC 29

reefblue 'n' apricot



Trapeze | iridium 'n' hazypurple



Trapeze | reefblue 'n' apricot



At CUBE we never stop exploring, questioning and seeking out new adventures. If that sounds like you, the new Access Hybrid EXC should be right up your street. Completely revised for 2020 and built around our innovative new Modular Battery System and 29er wheels, it's a stunningly elegant manifestation of our need to get out as often as possible and ride – a Bosch e-MTB for the adventurous woman. Clever features like an easy dropper post upgrade option, in-frame charging and a battery cover that's easy to access mean you're ready for anything. The extra space freed up by the new battery housing even allows us to offer the option of a higher capacity Bosch power unit, for even more range. Agile Ride Geometry combined with an X12 Boost rear axle, oversized chain stays and a 1.5in head tube makes for stunningly accurate, confidence-inspiring handling – and the 120mm Suntour XCR34 fork and extra-wide, grippy Schwalbe 2.6in tyres ensure you're always in full control. We routed cables internally to complement the frame's stunning good looks and ensure long-lasting, trouble-free gear shifting from the 12-speed Shimano SLX and XT transmission. And powerful Shimano hydraulic disc brakes mean you've always got the power at hand to stop reliably, whatever the weather throws at you. But star of the show, of course, is Bosch's fourth-generation drive unit. Smooth, powerful and incredibly easy to control, it's the invisible helping hand that'll extend your range, get you up climbs you never dreamed possible, and open up whole new frontiers of riding. Dare to dream, live to ride, grab every opportunity. The Access Hybrid EXC will be right there with you.

- ★ **338282** Cube Access Hybrid EXC 625 29 reefblue 'n' apricot 2020
- 338281** Cube Access Hybrid EXC 500 29 reefblue 'n' apricot 2020
- 338272** Cube Access Hybrid EXC 625 29 iridium 'n' hazypurple 2020
- 338271** Cube Access Hybrid EXC 500 29 iridium 'n' hazypurple 2020

**FRAME** Aluminium Superlite, Gravity Casting, Agile Ride Geometry, 1.5 Headtube, Boost 148, Internal Cable Routing, Full Integrated Battery, Kickstand/Fender/Carrier Mounting Points  
**SIZE** #5", 17", 19", Trapeze: 15", 17", 19"  
**FORK** Suntour XCR34 LO-R Air, Tapered, 15x110mm, 120mm, Lockout

**DRIVE UNIT** Bosch Drive Unit Performance CX Generation 4 (75Nm) Cruise (250Watt)  
**BATTERY** Bosch PowerTube 625  
**DISPLAY** Bosch Purion  
**CHARGER** Bosch 2A

**HEADSET** SA Orbit Z 1.5B ZS, Top Zero-Stack 1 1/2" (OD 56mm), Bottom Zero-Stack 1 1/2" (OD 56mm)  
**STEM** CUBE Performance Stem, 31.8mm  
**HANDLEBAR** CUBE Rise Trail Bar, 700mm  
**GRIPS** Natural Fit All Terrain  
**REAR DERAILLEUR** Shimano XT RD-M8100-SGS, ShadowPlus, 12-Speed  
**SHIFTERS** Shimano SLX SL-M7100  
**BRAKE SYSTEM** Shimano BR-MT420/MT400, Hydr. Disc Brake (203/180)  
**CRANKSET** CID E-Crank, 38T, 170mm  
**CASSETTE** Shimano SLX CS-M7100, 10-51T  
**CHAIN** Shimano SLX CN-M7100  
**RIMS** CUBE EX30, 32H, Disc, Tubeless Ready  
**FRONT HUB** Shimano HB-MT400-B, 15mm, Boost, Centerlock  
**REAR HUB** Shimano FH-MT510-B, 12mm, Boost, Centerlock  
**TYRES** Schwalbe Smart Sam, Active, 2.60  
**PEDALS** CUBE PP MTB  
**SADDLE** Natural Fit Sequence WS  
**SEAT POST** CUBE Performance Post, 30.9mm  
**SEATCLAMP** CUBE Varioclose, 34.9mm

**WEIGHT** #3,1 kg

- SPARE PARTS#**
- 8000** CUBE Headset Orbit Z 1.5E ZS
  - 8651** CUBE HANGER\_mtb-x12-std-2020 (18-05516)



**11049**  
CUBE ORGANIC WS 3/4 SHIRT LOGO 3.0



**16174**  
CUBE HELMET PATHOS



**10778**  
CUBE AM WS JERSEY

# ACCESS HYBRID EX 29

black'n'aqua



# ACCESS HYBRID EX 29

titan'n'berry



Trapeze | black'n'aqua



Trapeze | titan'n'berry



11291

CUBE TOUR WS JERSEY



11290

CUBE TOUR WS BAGGY SHORTS



16169

CUBE HELMET ROOK

You know that niggling feeling that your bike might, just possibly, be holding you back a little? You won't get that with the new Access Hybrid EX. Combining a brand-new 29er e-bike frame with a 120mm fork, Boost rear end and powerful fourth-generation Bosch CX drive system, it leaves nothing on the table in pursuit of trail-riding e-bike nirvana. Our engineering team pulled out all the stops to create a more versatile, better handling and easier to live with e-MTB specifically for women – and it's even available as a trapeze frame. Starting with our new Modular Battery System, they created a gravity cast down tube that entirely encloses the powerful Bosch power unit behind a cover. The result isn't just neat, it's also freed up enough space for the option of a more powerful 625Wh battery for extended range. With internal cable routing – including for a future dropper post upgrade – and features aimed at reliable, intuitive handling, it's all the e-MTB you're ever likely to need. The Suntour XCM34 Boost suspension fork has the travel and steering precision to keep you comfortable and out of trouble, aided and abetted by big, grippy Schwalbe Smart Sam tyres and powerful Shimano hydraulic disc brakes with big 203mm rotors at the front – so you'll always be in full control. Meanwhile, the Purion-controlled Bosch motor boosts your pedalling input via Sram's incredible SX Eagle 12-speed transmission, giving you the torque and gear range to easily tackle climbs that you previously considered unrideable. Put it all together and it's clear that, if you're not feeling it out on the trail, it's not the bike that's the problem. Ride more, ride further, ride faster. What are you waiting for?

- ★ **338262** Cube Access Hybrid EX 625 29 titan'n'berry 2020
- 338261** Cube Access Hybrid EX 500 29 titan'n'berry 2020
- 338252** Cube Access Hybrid EX 625 29 black'n'aqua 2020
- 338251** Cube Access Hybrid EX 500 29 black'n'aqua 2020

**FRAME** Aluminium Superlite, Gravity Casting, Agile Ride Geometry, 1.5 Headtube, Boost 148, Internal Cable Routing, Full Integrated Battery, Kickstand/Fender/Carrier Mounting Points  
**SIZE** #5", 17", 19", Trapeze: 15", 17", 19"  
**FORK** SR Suntour XCM34 Coil, Tapered, 15x110mm, 120mm, Lockout

**DRIVE UNIT** Bosch Drive Unit Performance CX Generation 4 (75Nm) Cruise (250Watt)  
**BATTERY** Bosch PowerTube 625  
**DISPLAY** Bosch Purion  
**CHARGER** Bosch 2A

**HEADSET** SA Orbit Z 1.5B ZS, Top Zero-Stack 1 1/2" (OD 56mm), Bottom Zero-Stack 1 1/2" (OD 56mm)  
**STEM** CUBE Performance Stem, 31.8mm  
**HANDLEBAR** CUBE Rise Trail Bar, 700mm  
**GRIPS** Natural Fit All Terrain  
**REAR DERAILLEUR** Sram SX Eagle™, 12-Speed  
**SHIFTERS** Sram SX Eagle™ Trigger, Single Click  
**BRAKE SYSTEM** Shimano BR-MT420/MT400, Hydr. Disc Brake (203/180)  
**CRANKSET** CID E-Crank, 38T, 170mm  
**CASSETTE** Sram PG-1210 Eagle™, 11-50T  
**CHAIN** Sram SX Eagle™  
**RIMS** CUBE EX30, 32H, Disc, Tubeless Ready  
**FRONT HUB** Shimano HB-MT400-B, 15mm, Boost, Centerlock  
**REAR HUB** Shimano FH-MT400-B, 12mm, Boost, Centerlock  
**TYRES** Schwalbe Smart Sam, Active, 2.60  
**PEDALS** CUBE PP MTB  
**SADDLE** Natural Fit Sequence WS  
**SEAT POST** CUBE Performance Post, 30.9mm  
**SEATCLAMP** CUBE Varioclose, 34.9mm

**WEIGHT** #4,1 kg

- SPARE PARTS#**
- 8000** CUBE Headset Orbit Z 1.5E ZS
  - 8651** CUBE HANGER\_mtb-x12-std-2020 (18-05516)

# ACCESS HYBRID EX ALLROAD 29

Trapeze | titan'n'berry



# ACCESS HYBRID EX ALLROAD 29

titan'n'berry



We've always thought that the saying „Jack of all trades, master of none“ was rather unfair on Jack – and the Access Hybrid EX Allroad is a case in point. By taking our versatile, well-equipped Access Hybrid EX e-MTB and equipping it with Bosch's CX Generation 4 drive unit, we've created a bike that can take on anything. From weekend trails in the mountains to weekday commuting and everything in-between, it's got the kit that you need – and, with the option of both standard and trapeze frames, every woman can find her perfect fit. We know that practicality is a key concern for some riders, so you'll be glad to know that the front and rear lights, mudguards and CUBE kickstand are standard features. The powerful Bosch power unit is completely contained inside the down tube, protected by an easy-access cover – and the extra space that this arrangement has freed up means there's the option of an even larger capacity battery, for extra range. Fast-rolling 29er wheels shod with big-volume, grippy Schwalbe tyres work with the Suntour XCM34 Boost fork's 120mm of travel to serve up all the comfort and control you need, whether you're tackling mean city streets or technical forest trails. Strong, progressive Shimano hydraulic disc brakes have got your back on the descents, while the fourth-generation Bosch drive unit and Sram SX Eagle 12-speed transmission give you the power and gear range to take on any climb with ease. The Natural Fit women's saddle and carefully chosen contact points, combined with our Agile Ride Geometry, make for fit and handling that feels completely natural. And, of course, you've the reassurance of knowing that the Access Hybrid EX Allroad has passed every in-house safety test we could throw at it. So don't fret about Jack not being up to the job. Because the Access Hybrid EX Allroad definitely is... whatever the job in question.

- ★ **338267** Cube Access Hybrid EX 625 Allroad 29 titan'n'berry 2020
- ★ **338266** Cube Access Hybrid EX 500 Allroad 29 titan'n'berry 2020

**FRAME** Aluminium Superlite, Gravity Casting, Agile Ride Geometry, 1.5 Headtube, Internal Cable Routing, Semi-Integrated Battery, Kickstand/Fender/Carrier Mounting Points  
**SIZE** #5", 17", 19", Trapeze: 15", 17", 19"  
**FORK** R Suntour XCM34 Coil, Tapered, 15x110mm, 120mm, Lockout

**DRIVE UNIT** Bosch Drive Unit Performance CX Generation 4 (75Nm) Cruise (250Watt)  
**BATTERY** Bosch PowerTube 625  
**DISPLAY** Bosch Purion  
**CHARGER** Bosch 2A

**HEADSET** SA Orbit Z 1.5B ZS, Top Zero-Stack 1 1/2" (OD 56mm), Bottom Zero-Stack 1 1/2" (OD 56mm)  
**STEM** CUBE Performance Stem, 31.8mm  
**HANDLEBAR** CUBE Rise Trail Bar, 700mm  
**GRIPS** Natural Fit All Terrain  
**REAR DERAILLEUR** Sram SX Eagle™, 12-Speed  
**SHIFTERS** Sram SX Eagle™ Trigger, Single Click  
**BRAKE SYSTEM** Shimano BR-MT420/MT400, Hydr. Disc Brake (203/180)  
**CRANKSET** CID E-Crank, 38T, 170mm  
**CASSETTE** Sram PG-1210 Eagle™, 11-50T  
**CHAIN** Sram SX Eagle™  
**RIMS** CUBE EX30, 32H, Disc, Tubeless Ready  
**FRONT HUB** Shimano HB-MT400-B, 15mm, Boost, Centerlock  
**REAR HUB** Shimano FH-MT400-B, 12mm, Boost, Centerlock  
**TYRES** Schwalbe Smart Sam, Active, 2.60  
**PEDALS** CUBE PP MTB  
**SADDLE** Natural Fit Sequence WS  
**SEAT POST** CUBE Performance Post, 30.9mm  
**SEATCLAMP** CUBE Varioclose, 34.9mm  
**FRONT LIGHT** AXA Compactline 20, 6-12V, DC  
**REAR LIGHT** Busch&Müller Xeltec, DC  
**KICKSTAND** CUBEstand Cmp  
**MUDGUARDS** CID 75  
**BELL** Mini Bell

**SPARE PARTS**  
**8000** CUBE Headset Orbit Z 1.5E ZS  
**8651** CUBE HANGER\_mtb-x12-std-2020 (18-05516)

**WEIGHT** #5,4 kg

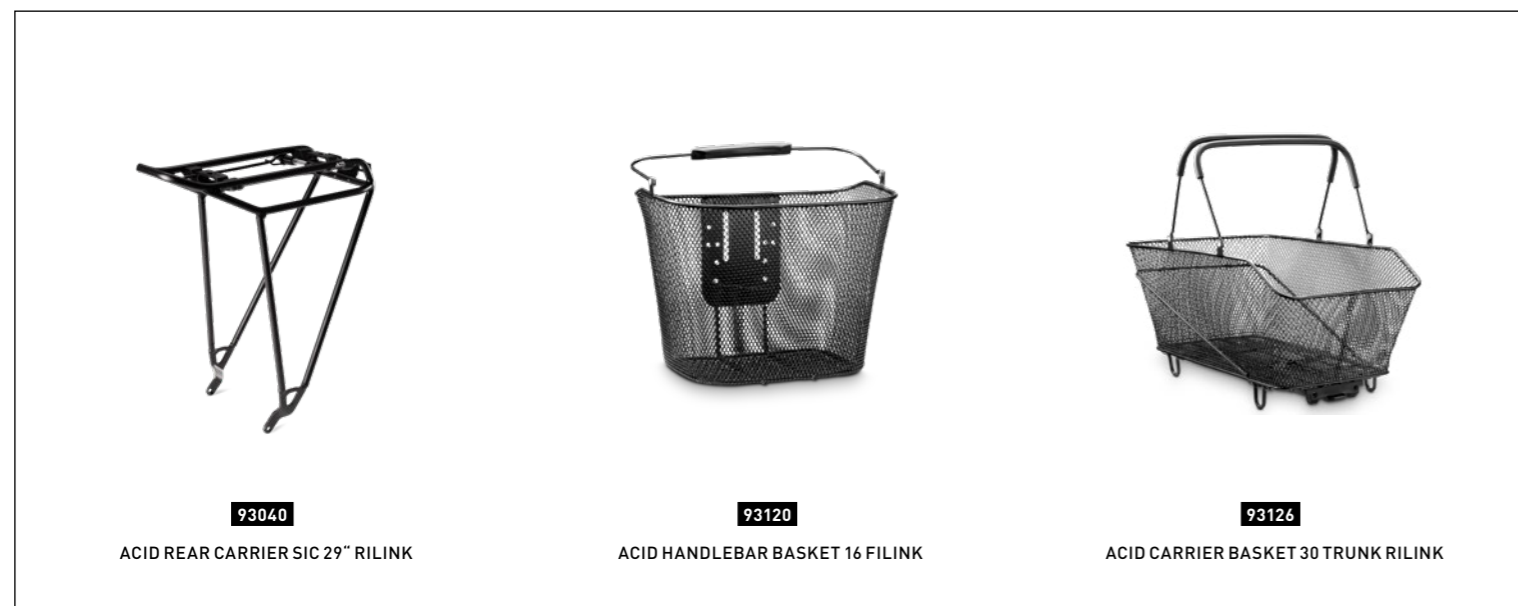

**93040**  
ACID REAR CARRIER SIC 29" RILINK

**93120**  
ACID HANDLEBAR BASKET 16 FILINK

**93126**  
ACID CARRIER BASKET 30 TRUNK RILINK

WOMEN'S SERIES



---

## FOR us #Women

---

You may have heard of the saying that the frame is the heart of any bicycle. We're a firm believer that that's true – and it's the reason that, for the fourth-generation Bosch-powered Access Hybrid, we set out to develop a brand-new frame. Drawing on all our experience of mountain bike hybrids, we refined an already highly regarded chassis with new features and better handling – and our Size Split system and trapeze frame option makes it easy for every woman to find her perfect fit. With 100mm of smooth fork travel and a seat tube and internal cable routing that's ready to accept a stealth dropper post, it's designed to be comfortable to ride, easy to live with and simple to upgrade as your riding skills progress and your needs change. We even included a kickstand mount, just in case that's something that you'd like to add. Backed by the reassurance of having passed all our strict in-house safety tests, the Access Hybrid is all you need to discover a whole new dimension to your riding.



# ACCESS HYBRID RACE

iridium'n' red



# ACCESS HYBRID RACE

pinetree'n'lime



What happens if you combine the rugged, go-anywhere ability of a mountain bike with the ease of use of a Bosch e-bike... and tailor it specifically for women? The brand-new, Bosch CX Generation 4-powered Access Hybrid Race is what happens – a bike that'll open up new horizons, whatever kind of riding you're into. Built around our brand-new Access frame with Size Split, so that you can be certain of finding exactly the right fit for you, this bike represents the culmination of years of expertise in design – of both great-handling women's mountain bikes and brilliantly reliable, powerful Bosch e-bikes. The clue is in the details. For example, you can charge the battery without removing it from the frame, and the motor cover can be removed with just a single screw. Integrated cable routing complements the frame's clean lines and keep gear shifts flawless even through dust, dirt and water, and we even added provision for a dropper post upgrade, should you find your riding becoming even more adventurous. But a frame is only as good as the parts bolted to it, and that's where the Access Hybrid Race really shines. From the RockShox Judy Silver air fork – easily adjustable for any rider weight and riding style – to the powerful Shimano hydraulic disc brakes and big-volume, tenaciously grippy Schwalbe 2.6in tyres, we've selected components that are renowned for their ease of use and reliability. Shimano's new XT and SLX 12-speed transmission works flawlessly with Bosch's drive system to deliver an incredible gear range and smooth, easy shifts. You'll be flying up climbs you never thought possible – and the 500Wh battery gives you the power you need to extend your riding horizons further than ever. We can promise you one thing: this bike will keep you coming back for more.

- ★ **338211** Cube Access Hybrid Race 500 pinetree'n'lime 2020
- ★ **338201** Cube Access Hybrid Race 500 iridium'n' red 2020

**FRAME** Aluminium Superlite, Gravity Casting, Agile Ride Geometry, 1.5 Headtube, Internal Cable Routing, Semi-Integrated Battery, Kickstand/Fender/Carrier Mounting Points  
**SIZE** Size Split: 27.5: 13.5", 15" // 29: 17", 19"  
**FORK** RockShox Judy Silver TK Air, Tapered, 15x110mm, 100mm, eMTB Approved, Lockout

**DRIVE UNIT** Bosch Drive Unit Performance CX Generation 4 (75Nm) Cruise (250Watt)  
**BATTERY** Bosch PowerPack 500  
**DISPLAY** Bosch Purion  
**CHARGER** Bosch 2A

**HEADSET** SA Orbit Z 1.5B Z5, Top Zero-Stack 1 1/2" (OD 56mm), Bottom Zero-Stack 1 1/2" (OD 56mm)  
**STEM** CUBE Performance Stem, 31.8mm  
**HANDLEBAR** CUBE Rise Trail Bar Pro, 720mm  
**GRIPS** Natural Fit All Terrain  
**REAR DERAILLEUR** Shimano XT RD-M8100-SGS, ShadowPlus, 12-Speed  
**SHIFTERS** Shimano SLX SL-M7100  
**BRAKE SYSTEM** Shimano BR-MT420, Hydr. Disc Brake (180/180)  
**CRANKSET** CID E-Crank, 38T, 170mm  
**CASSETTE** Shimano SLX CS-M7100, 10-51T  
**CHAIN** Shimano SLX CN-M7100  
**RIMS** CUBE EX30, 32H, Disc, Tubeless Ready  
**FRONT HUB** Shimano HB-MT400-B, 15mm, Boost, Centerlock  
**REAR HUB** Shimano FH-MT500, QR, Centerlock  
**TYRES** Schwalbe Smart Sam, Active, 2.60  
**PEDALS** CUBE PP MTB  
**SADDLE** Natural Fit Sequence WS  
**SEAT POST** CUBE Performance Post, 30.9mm  
**SEATCLAMP** CUBE Varioclose, 34.9mm

**WEIGHT** 1,7 kg

**SPARE PARTS**  
**8000** CUBE Headset Orbit Z 1.5E Z5  
**10148** CUBE Hanger #148 short version



**11443**  
SQUARE WS JERSEY PERFORMANCE



**11421**  
SQUARE WS BAGGY SHORTS ACTIVE



**17076**  
CUBE SHOES MTB PEAK PRO

# ACCESS HYBRID PRO

black'n'mint



# ACCESS HYBRID PRO

white'n'berry



Trapeze | black'n'mint



Trapeze | white'n'berry



The Access Hybrid Pro combines the riding experience of a real mountain bike with the unhampered mobility and freedom that only a fourth-generation Bosch e-bike can offer. It's a powerful combination, and one which we're sure you're going to love. Brand new for 2020, our engineers have created an entirely fresh frame design. Built around the specific requirements of Bosch's superb CX drive unit, it draws on our years of experience working on both hybrids and mountain bike design to create an elegant, functional and easy-to-live-with frame. With an On-tube battery mount and neat features like integrated cable routing, we've put the emphasis on easy handling and dependable reliability – and we're super-confident making that claim, because as with all our frames we've put it through the mill in our own in-house lab to ensure it's more than strong and durable enough for the job. Sram's incredible SX Eagle 12-speed gears provide easy selection and an amazing range of ratios – more than enough to tackle even the steepest of climbs with ease, when combined with the smooth torque and effortless power delivery of the Bosch system. The Suntour suspension fork works with the extra-wide 2.6in Schwalbe tyres to smooth out the trail ahead, and powerful Shimano hydraulic disc brakes ensure you've always plenty of power to control your speed, come rain or shine. It's everything you need for trail-exploring fun, so what's stopping you?

- ★ **338111** Cube Access Hybrid Pro 500 white'n'berry 2020
- 338101** Cube Access Hybrid Pro 500 black'n'mint 2020

**FRAME** Aluminium Superlite, Gravity Casting, Agile Ride Geometry, 1.5 Headtube, Internal Cable Routing, Semi-Integrated Battery, Kickstand/Fender/Carrier Mounting Points  
**SIZE** Size Split: 27.5: 13.5", 15" // 29: 17", 19"; Trapeze 27.5: 15" // 29: 17", 19"  
**FORK** Suntour XCM34 Coil, Tapered, 15x110mm, 100mm, Lockout

**DRIVE UNIT** Bosch Drive Unit Performance CX Generation 4 (75Nm) Cruise (250Watt)  
**BATTERY** Bosch PowerPack 500  
**DISPLAY** Bosch Purion  
**CHARGER** Bosch 2A

**HEADSET** SA Orbit Z 1.5B ZS, Top Zero-Stack 1 1/2" (OD 56mm), Bottom Zero-Stack 1 1/2" (OD 56mm)  
**STEM** CUBE Performance Stem, 31.8mm  
**HANDLEBAR** CUBE Rise Trail Bar, 700mm  
**GRIPS** Natural Fit All Terrain  
**REAR DERAILLEUR** Sram SX Eagle™, 12-Speed  
**SHIFTERS** Sram SX Eagle™ Trigger, Single Click  
**BRAKE SYSTEM** Shimano BR-MT200, Hydr. Disc Brake (180/180)  
**CRANKSET** CID E-Crank, 38T, 170mm  
**CASSETTE** Sram PG-1210 Eagle™, 11-50T  
**CHAIN** Sram SX Eagle™  
**RIMS** CUBE EX30, 32H, Disc, Tubeless Ready  
**FRONT HUB** Shimano HB-MT400-B, 15mm, Boost, Centerlock  
**REAR HUB** Shimano FH-TX505, QR, Centerlock  
**TYRES** Schwalbe Smart Sam, Active, 2.60  
**PEDALS** CUBE PP MTB  
**SADDLE** Natural Fit Sequence WS  
**SEAT POST** CUBE Performance Post, 30.9mm  
**SEATCLAMP** CUBE Varioclose, 34.9mm

**WEIGHT** #2,9 kg

**SPARE PARTS#**  
**8000** CUBE Headset Orbit Z 1.5E ZS  
**10148** CUBE Hanger #148 short version



11017

CUBE BLACKLINE WS JERSEY



11021

CUBE BLACKLINE WS BIB SHORTS



16253

CUBE HELMET ROOK

# ACCESS HYBRID PRO ALLROAD

Trapeze | black'n'mint



# ACCESS HYBRID PRO ALLROAD

black'n'mint



A mountain bike is a versatile beast; a Bosch e-MTB even more so. But should you have to spend more to equip a new bike to fit your busy life? No, we didn't think so either. That's the thinking behind the Access Hybrid Pro Allroad – a Bosch e-bike for all reasons and all terrain, designed specifically to meet the needs of women riders. Featuring an all-new frame and Bosch's fourth-generation CX drive unit for 2020, it's packed with features to make it sleeker to look at and easier to use than ever. Our Size Split system – and the option of standard or trapeze frames – makes it easy to find just the right fit for you, whilst carefully selected contact components including a women's Natural Fit saddle ensure that you'll be comfortable on every ride. Integrated cable routing complements the frame's sculpted looks as well as reducing the need for maintenance, and you can even charge the battery without removing it from the frame. Our Allroad component kit adds day-to-day practicality in spades – from the extra splash protection afforded by the mudguards to the versatile kickstand and added safety of the front and rear lighting system, it all makes for a bike that'll slot right into your life. And, with Sram's wide-ranging 12-speed Eagle transmission working seamlessly with Bosch's proven drive technology, you've the range and power to tackle everything from steep climbs to longer days out. Powerful Shimano hydraulic disc brakes and extra-wide, grippy Schwalbe tyres ensure you're always in full control, and the Suntour suspension fork helps smooth out the path ahead. Combine all this with the reassurance of knowing that it's passed our strict in-house safety tests with flying colours, and you've got the ultimate go-anywhere, do-anything all-rounder – just jump on and ride. Where will it take you next?

★ **338151** Cube Access Hybrid Pro 500 Allroad black'n'mint 2020

**FRAME** Aluminium Superlite, Gravity Casting, Agile Ride Geometry, 1.5 Headtube, Internal Cable Routing, Semi-Integrated Battery, Kickstand/Fender/Carrier Mounting Points  
**SIZE** Size Split: 27.5: 13.5", 15" // 29: 17", 19"; Trapeze 27.5: 15" // 29: 17", 19"  
**FORK** Suntour XCM34 Coil, Tapered, 15x110mm, 100mm, Lockout

**DRIVE UNIT** Bosch Drive Unit Performance CX Generation 4 (75Nm) Cruise (250Watt)  
**BATTERY** Bosch PowerPack 500  
**DISPLAY** Bosch Purion  
**CHARGER** Bosch 2A

**HEADSET** SA Orbit Z 1.5B ZS, Top Zero-Stack 1 1/2" [OD 56mm], Bottom Zero-Stack 1 1/2" [OD 56mm]  
**STEM** CUBE Performance Stem, 31.8mm  
**HANDLEBAR** CUBE Rise Trail Bar, 700mm  
**GRIPS** Natural Fit All Terrain  
**REAR DERAILLEUR** Sram SX Eagle™, 12-Speed  
**SHIFTERS** Sram SX Eagle™ Trigger, Single Click  
**BRAKE SYSTEMS** Shimano BR-MT200, Hydr. Disc Brake (180/180)  
**CRANKSET** CID E-Crank, 38T, 170mm  
**CASSETTE** Sram PG-1210 Eagle™, 11-50T  
**CHAIN** Sram SX Eagle™  
**RIMS** CUBE EX30, 32H, Disc, Tubeless Ready  
**FRONT HUB** Shimano HB-MT400-B, 15mm, Boost, Centerlock  
**REAR HUB** Shimano FH-TX505, QR, Centerlock  
**TYRES** Schwalbe Smart Sam, Active, 2.60  
**PEDALS** CUBE PP MTB  
**SADDLE** Natural Fit Sequence WS  
**SEAT POST** CUBE Performance Post, 30.9mm  
**SEATCLAMP** CUBE Varioclose, 34.9mm  
**FRONT LIGHT** AXA Compactline 20, 6-12V, DC  
**REAR LIGHT** Busch&Müller Xeltec, DC  
**KICKSTAND** CUBEstand CmpT  
**MUDGUARDS** CID 75  
**BELL** Mini Bell

**WEIGHT** #4,2 kg

**SPARE PARTS**  
**8000** CUBE Headset Orbit Z 1.5E ZS  
**10148** CUBE Hanger #148 short version

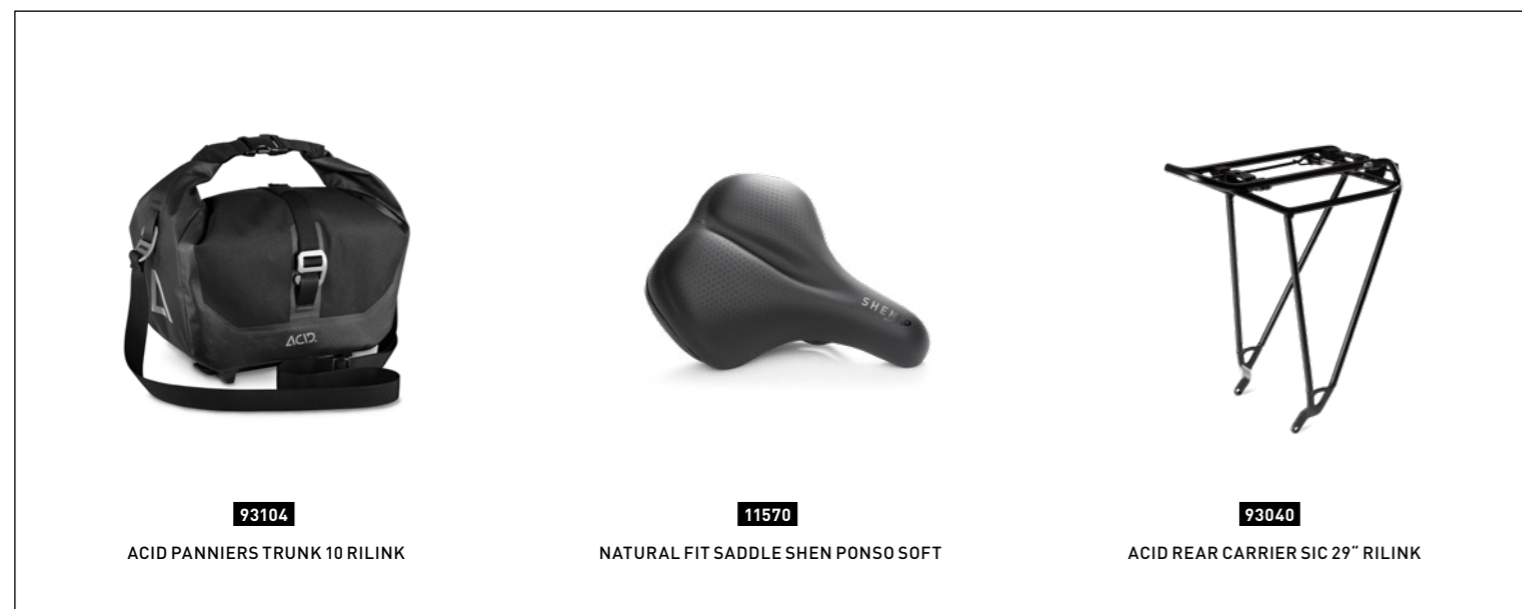

**93104**  
ACID PANNIERS TRUNK 10 RILINK

**11570**  
NATURAL FIT SADDLE SHEN PONSO SOFT

**93040**  
ACID REAR CARRIER SIC 29" RILINK

WOMEN'S SERIES

# ACCESS HYBRID ONE

grey'n'aqua



Not available in all markets.



16289

CUBE HELMET QUEST



11291

CUBE TOUR WS JERSEY



11020

CUBE BLACKLINE WS RADHOSE

# T O U R



186 **CROSS**

194 **NATURE**

200 **KATHMANDU**

220 **TOURING**

**COMFORT**  
COMFORT

**TOUR**  
TOUR

**SPORT**  
SPORT



**CROSS**

Adaptable, versatile, tough: that's the all new, fourth generation Bosch-powered Cross Hybrid. Not surprising, really - we applied all the lessons we learnt developing mountain bike hybrids into this comfortable all-rounder. You'll wonder how you managed without it.

**NATURE**

If the bicycle is one of humankind's greatest inventions - and we think it is - then the Nature Hybrid is one of the finest examples of its kind. Comfortable, practical, easy to live with and powered by Bosch's smooth and reliable drive unit, it's the life companion you didn't realise you were missing.

**KATHMANDU**

Drive your adventurous spirit. The all new Kathmandu Hybrid is the fourth generation Bosch-powered tourer tough enough to take on the world. From its integrated luggage carrier to the powerful Bosch drive unit and reliable components, it's got all you need to feed your curiosity.

**TOURING**

Whatever you do, wherever you go, the Touring Hybrid will be there with you. Beautifully integrated into its sleek frame, the third generation Bosch drive system and super smooth, neutral handling mean you're all set to tackle life's challenges and adventures head on. Ride adventurously, travel often.

---

## FOR us #Pathfinders

---

Built around Bosch's smooth, powerful fourth-generation drive system, the new Cross Hybrid frame represents a completely new approach to our trekking hybrids. Building on the experience gained from developing a new breed of mountain bike hybrids, our engineering team set about creating a frame that's sleeker, more practical and better to ride than ever. Key to its success is our new Modular Battery System, which houses the Bosch power unit completely inside the gravity cast down tube. Hidden from view behind an easily accessed cover, the new setup leaves room for bottle cage mounts – so you can stay hydrated on longer rides – and frees up enough space for the option of an even larger capacity battery for extended range. A tapered head tube ensures accurate steering, integrated cable routing keeps gear shifts clean and accurate with minimal maintenance and geometry designed around a 100mm suspension fork means that the new generation of Cross Hybrids are more comfortable to ride – and more versatile – than ever. We're proud of the Cross Hybrid. We think you will be too.



# CROSS HYBRID SL ALLROAD

Trapeze | iridium'n'white



# CROSS HYBRID SL ALLROAD

iridium'n'white



The all-new Cross Hybrid SL Allroad is the pinnacle of our versatile Cross Hybrid range. Our designers wanted a Bosch e-bike that cut no corners in its pursuit of the ideal blend of comfort, safety and performance. So, taking their inspiration from the CUBE mountain bike range and beginning with a blank sheet of paper, they applied the same principles – sleek lines, brilliant handling, no-compromise function – to come up with the bike you see here. Completely reworked from front to rear, the frame's stunning looks disguise a masterclass in integrated design. The fourth-generation Bosch CX drive unit – smaller, lighter and more powerful than before – sits in a new housing complete with mesh cover, keeping the bike's centre of gravity low for safe handling. A brand-new 625Wh modular battery sits inside a dedicated down tube housing, safe from the elements and easy to recharge even in situ. There's even room for bottle cage mounts, so you can stay hydrated on longer rides. The tapered head tube accommodates a smooth, easily adjustable RockShox Judy Gold fork with 100mm of travel and accurate steering on even the roughest of roads, while internal cable routing keeps the Shimano XT 12-speed transmission's shifts precise and smooth with minimal maintenance. Included full-length mudguards incorporate a rear light to accompany the fitted front light, so you're never caught short at the end of the day. The included CUBE kickstand and neatly integrated carrier mounts for a luggage rack upgrade add the finishing touches, and we even upgraded the powerful hydraulic disc brakes to a more powerful setup at both front and rear for assured stopping in any weather. We're confident it'll fit into your busy, active lifestyle just perfectly. Which leaves only one question: where will you ride tomorrow?

★ **330302** Cube Cross Hybrid SL 625 Allroad iridium'n'white 2020

**FRAME** Aluminum Superlite, Gravity Casting Technology, Efficient Comfort Geometry, Tapered Headtube, Full Integrated Battery, Kickstand/Fender/Carrier Mounting Points  
**SIZE** Men: 50, 54, 58, 62; Trapeze: 46, 50, 54  
**FORK** RockShox Judy Gold Air, Tapered, 15x110mm, 100mm, eMTB Approved, Lockout

**DRIVE UNIT** Bosch Drive Unit Performance CX Generation 4 (75Nm) Cruise (250Watt)  
**BATTERY** Bosch PowerTube 625  
**DISPLAY** Bosch Kiox  
**CHARGER** Bosch 4A

**HEADSET** SA 1.5E ZS, Tapered, Top Zero-Stack 1 1/8" (OD 44mm), Bottom Zero-Stack 1 1/2" (OD 56mm)  
**STEM** Newmen Evolution 318.4, 31.8mm  
**HANDLEBAR** Newmen Evolution 318.10, 720mm  
**GRIPS** Natural Fit All Terrain  
**REAR DERAILLEUR** Shimano XT RD-M8100-SGS, ShadowPlus, 12-Speed  
**SHIFTERS** Shimano XT SL-M8100-IR, Direct Attach  
**BRAKE SYSTEMS** Shimano XT BR-M8120, Hydr. Disc Brake (180/180)  
**CRANKSET** CID E-Crank, 38T, 175mm  
**CASSETTE** Shimano SLX CS-M7100, 10-51T  
**CHAIN** Shimano SLX CN-M7100  
**RIMS** CUBE EX23, 36H, Disc, Tubeless Ready  
**FRONT HUB** Shimano HB-MT400-B, 15mm, Boost, Centerlock  
**REAR HUB** Shimano FH-MT500, QR, Centerlock  
**TYRES** Schwalbe Smart Sam, Active, 57-622  
**PEDALS** CUBE PP MTB  
**SADDLE** Natural Fit Sequence+ Comfort  
**SEAT POST** CUBE Performance Post, 30.9mm  
**SEATCLAMP** CUBE Varioclose, 34.9mm  
**FRONT LIGHT** Herrmans H-Black MR8, 6-12V, DC  
**REAR LIGHT** Busch&Müller Xeltec, DC  
**KICKSTAND** CUBEstand Cmp  
**MUDGUARDS** CID 65  
**BELL** Knog Oi

**SPARE PARTS**  
**10148** CUBE Hanger #148 short version  
**10338** CUBE Headset Orbit 1.5E ZS 1 1/8 / 1.5 semi + 1 1/8 crown race

**WEIGHT** #3.5 kg

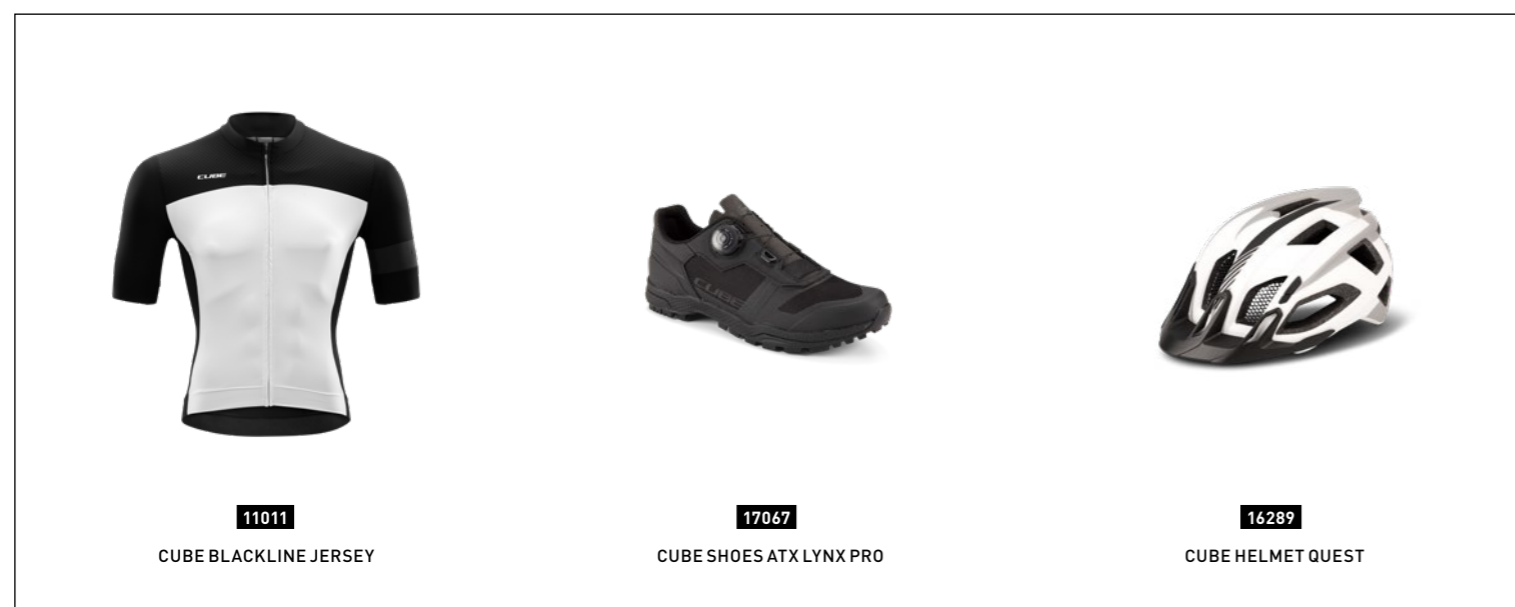

11011

CUBE BLACKLINE JERSEY

17067

CUBE SHOES ATX LYNX PRO

16289

CUBE HELMET QUEST





# CROSS HYBRID RACE ALLROAD

black 'n' green



# CROSS HYBRID RACE ALLROAD

blue 'n' orange



Trapeze | black 'n' green



Trapeze | blue 'n' orange



Who says practical can't be fun? When our engineering team set out to design the all-new Cross Hybrid Race Allroad, they had everyday versatility at the forefront of their minds. But, as riders themselves, they also wanted to create a hybrid that's fun to ride. So the Cross Hybrid Race Allroad blends all our frame-building know-how with Bosch's powerful new fourth-generation CX drive unit and a selection of smooth, reliable components – so you can concentrate on enjoying the journey. The brand-new frame takes inspiration from our mountain bike hybrids, encompassing a new, modular and enclosed battery system and a motor mount that's so sleekly integrated into the frame's smooth lines, you'll find it hard to believe it's a hybrid. The centre of gravity is low for safe, intuitive handling – and, like all CUBE frames, this one's passed our in-house torture testing with flying colours, so you know it's safe and durable. Slick-shifting, reliable and wide-ranging Shimano XT 12-speed gears make climbing any hill a breeze, while the 500Wh or 625Wh battery gives you extended range – and there's no need to remove it from the frame for charging. Powerful hydraulic disc brakes, full-length mudguards and an integrated lighting system equip you for all weathers and any time of day, and neatly integrated rack mounting points make it easy to extend your Cross Hybrid Race's cargo-carrying abilities. Meanwhile, grippy Schwalbe Smart Sam tyres and a 100mm travel, air-sprung Suntour suspension fork give the confidence you need to tackle city streets or country roads in comfort. Put it all together, and the Cross Hybrid Race is the consummate all-rounder for work, for play... and everything in between.

- ★ **330262** Cube Cross Hybrid Race 625 Allroad blue 'n' orange 2020
- 330261** Cube Cross Hybrid Race 500 Allroad blue 'n' orange 2020
- 330252** Cube Cross Hybrid Race 625 Allroad black 'n' green 2020
- 330251** Cube Cross Hybrid Race 500 Allroad black 'n' green 2020

**FRAME** Aluminum Superlite, Gravity Casting Technology, Efficient Comfort Geometry, Tapered Headtube, Full Integrated Battery, Kickstand/Fender/Carrier Mounting Points  
**SIZE** Men: 50, 54, 58, 62; Trapeze: 46, 50, 54  
**FORK** Suntour XCR32 LO-R Air, 100mm, Lockout

**DRIVE UNIT** Bosch Drive Unit Performance CX Generation 4 (75Nm) Cruise (250Watt)  
**BATTERY** Bosch PowerTube 625  
**DISPLAY** Bosch Kiox  
**CHARGER** Bosch 2A

**HEADSET** SA Orbit 1.5B ZS-R, Top Zero-Stack 1 1/8" (OD 44mm), Bottom Zero-Stack 1 1/2" (OD 56mm)  
**STEM** CUBE Performance Stem Pro, 31.8mm  
**HANDLEBAR** CUBE Rise Trail Bar, 700mm  
**GRIPS** Natural Fit All Terrain  
**REAR DERAILLEUR** Shimano XT RD-M8100-SGS, ShadowPlus, 12-Speed  
**SHIFTERS** Shimano SLX SL-M7100  
**BRAKE SYSTEM** Shimano BR-MT420/MT400, Hydr. Disc Brake (180/180)  
**CRANKSET** CID E-Crank, 38T, 175mm  
**CASSETTE** Shimano SLX CS-M7100, 10-51T  
**CHAIN** Shimano SLX CN-M7100  
**RIMS** CUBE EX23, 36H, Disc, Tubeless Ready  
**FRONT HUB** Shimano HB-M4050, QR, Centerlock  
**REAR HUB** Shimano FH-MT500, QR, Centerlock  
**TYRES** Schwalbe Smart Sam, Active, 57-622  
**PEDALS** CUBE PP MTB  
**SADDLE** Natural Fit Sequence+ Comfort  
**SEAT POST** CUBE Performance Post, 30.9mm  
**SEATCLAMP** CUBE Varioclose, 34.9mm  
**FRONT LIGHT** Herrmans H-Black MR8, 6-12V, DC  
**REAR LIGHT** Busch&Müller Xeltec, DC  
**KICKSTAND** CUBEstand Cmp  
**MUDGUARDS** CID 65  
**BELL** Mini Bell

**WEIGHT** 4,2 kg

- SPARE PARTS#**
- 10148** CUBE Hanger #148 short version
  - 10338** CUBE Headset Orbit 1.5E ZS 1 1/8 / 1.5 semi + 1 1/8 crown race



92048

ACID REAR CARRIER SIC 28" RILINK



93110

ACID PANNIERS TOPTUBE 1



13334

ACID FOLDING LOCK RIGID 90



# CROSS HYBRID PRO ALLROAD

iridium 'n' black



# CROSS HYBRID PRO ALLROAD

green 'n' orange



Trapeze | iridium 'n' black



Trapeze | green 'n' orange



Sometimes you just want a bike that'll do it all, with no fuss. That's what we had in mind when we built the Cross Hybrid Pro Allroad. Completely redesigned from the ground up for 2020, this versatile Shimano Deore-equipped Bosch e-bike redefines what's possible in a hybrid all-rounder. From the sleek, mountain bike-inspired frame to the grip of the wide 2.25in tyres and comfort of a 100mm suspension fork, every aspect of the Cross Hybrid Pro has been significantly improved. Bosch's fourth-generation CX drive unit and Modular Battery System – in powerful 500Wh or 625Wh options, for even more range – delivers smooth, reliable power in a package that's smaller, lighter and neater than ever before. Our engineers have worked overtime on the new frame, which is as practical as it is good-looking. From the integrated cable routing for long-lasting smooth shifting to the tapered head tube for super-precise steering and neat mounting points for luggage rack and a CUBE kickstand, we like to think we've thought of everything. The 10-speed Shimano transmission gives you the range you need to tackle any hill with confidence, whilst powerful Shimano hydraulic disc brakes bring you safely to a halt – and mudguards and lights are the practical extras that we've included so that you don't need to buy them. Put it all together, and the Cross Hybrid Pro Allroad is the everyday two-wheeled companion that'll help expand your horizons.

- ★ **330212** Cube Cross Hybrid Pro 625 Allroad green 'n' orange 2020
- 330211** Cube Cross Hybrid Pro 500 Allroad green 'n' orange 2020
- 330202** Cube Cross Hybrid Pro 625 Allroad iridium 'n' black 2020
- 330201** Cube Cross Hybrid Pro 500 Allroad iridium 'n' black 2020

**FRAME** Aluminum Superlite, Gravity Casting Technology, Efficient Comfort Geometry, Tapered Headtube, Full Integrated Battery, Kickstand/Fender/Carrier Mounting Points  
**SIZE** Men: 50, 54, 58, 62; Trapeze: 46, 50, 54  
**FORK** Suntour XCM ATB Coil, 100mm

**DRIVE UNIT** Bosch Drive Unit Performance CX Generation 4 (75Nm) Cruise (250Watt)  
**BATTERY** Bosch PowerTube 625  
**DISPLAY** Bosch Purion  
**CHARGER** Bosch 2A

**HEADSET** SA Orbit 1.5B ZS-R, Top Zero-Stack 1 1/8" (OD 44mm), Bottom Zero-Stack 1 1/2" (OD 56mm)  
**STEM** CUBE Performance Stem Pro, 31.8mm  
**HANDLEBAR** CUBE Rise Trail Bar, 700mm  
**GRIPS** Natural Fit All Terrain  
**REAR DERAILLEUR** Shimano Deore RD-M6000-GS, 10-Speed  
**SHIFTERS** Shimano Deore SL-M6000, Rapidfire-Plus  
**BRAKE SYSTEM** Shimano BR-MT200, Hydr. Disc Brake (180/180)  
**CRANKSET** CID E-Crank, 38T, 175mm  
**CASSETTE** Shimano Deore CS-HG500, 11-42T  
**CHAIN** MC X10  
**RIMS** CUBE EX23, 36H, Disc, Tubeless Ready  
**FRONT HUB** Shimano HB-TX505, QR, Centerlock  
**REAR HUB** Shimano FH-TX505, QR, Centerlock  
**TYRES** Schwalbe Smart Sam, Active, 57-622  
**PEDALS** CUBE PP MTB  
**SADDLE** Natural Fit Sequence Comfort  
**SEAT POST** CUBE Performance Post, 30.9mm  
**SEATCLAMP** CUBE Varioclose, 34.9mm  
**FRONT LIGHT** Herrmans H-Black MR4, 6-12V, DC  
**REAR LIGHT** Busch&Müller Xeltec, DC  
**KICKSTAND** CUBEstand Cmp  
**MUDGUARDS** CID 65  
**BELL** Mini Bell

**WEIGHT** 4.4 kg

**SPARE PARTS#**  
**10148** CUBE Hanger #148 short version  
**10338** CUBE Headset Orbit 1.5E ZS 1 1/8 / 1.5 semi + 1 1/8 crown race



11037

CUBE TOUR CORE JERSEY



11288

CUBE TOUR LIGHTWEIGHT SHORTS



17083

CUBE SHOES ATX OX



---

## FOR us #Offroaders

---

There's some clever technology lurking in the smooth, clean lines of the Nature Hybrid. Our engineering team worked overtime to position the Bosch battery and drive system optimally for both the men's and the trapeze frame designs. Using complex hydroforming and gravity casting, they created a frame that combines our Efficient Comfort Geometry with a low centre of gravity for handling that's completely intuitive – lively when you need it, stable the rest of the time. A light, stiff structure translates into a bike that's as easy to pedal as it is to steer. Internal cable routing complements the svelte appearance, and the added bonus is that gear cables tucked out of harm's way in the frame reduce maintenance and help to keep your gear shifts clean and smooth for longer. As we like to say at CUBE, it's the details that count.



# NATURE HYBRID EXC ALLROAD

black 'n' red



# NATURE HYBRID EXC ALLROAD

blue 'n' lime



Trapeze | black 'n' red



Trapeze | blue 'n' lime



When you need a bike that just works – to get you to the shops, across town or out into the countryside at the weekend – the Nature Hybrid EXC Allroad fits the bill. A versatile, well-equipped Bosch e-bike designed with everyday life in mind, it blends our years of experience building e-bikes with a component package that's as easy to use as it is versatile. So, for example, the integrated battery pack can be recharged without removing it from the frame, while the Busch & Müller rear light is neatly built into the rear mudguard – and runs off the same battery. The frame's svelte lines conceal the kind of attention to detail you'd expect from CUBE, including a low centre of gravity for safe handling, weight-saving aluminium double-butted tubing, and a clean bill of health from our thorough in-house safety testing. Shimano's smooth and reliable Deore 10-speed gears give you the range you need to tackle any hill easily, while powerful hydraulic disc brakes give safe, assured stopping in any weather conditions. We even included an easily adjustable Suntour air suspension fork, so your ride will be comfortable no matter how bumpy the road ahead.

- ★ **330161** Cube Nature Hybrid EXC 500 Allroad blue 'n' lime 2020
- ★ **330151** Cube Nature Hybrid EXC 500 Allroad black 'n' red 2020

**FRAME** Aluminium Superlite, Comfort, Full Integrated Battery, Double Butted  
**SIZE** Men: 50, 54, 58, 62; Trapeze: 46, 50, 54  
**FORK** Suntour NCX D LO Air, 63mm, Lockout

**DRIVE UNIT** Bosch Drive Unit Performance Generation 3 (65Nm) Cruise (250Watt)  
**BATTERY** Bosch PowerPack 500  
**DISPLAY** Bosch Purion  
**CHARGER** Bosch 2A

**HEADSET** SA Orbit 1.5B ZS-R, Top Zero-Stack 1 1/8" (OD 44mm), Bottom Zero-Stack 1 1/2" (OD 56mm)  
**STEM** CUBE Performance Stem Pro, 31.8mm  
**HANDLEBAR** CUBE Rise Trail Bar, 700mm  
**GRIPS** Natural Fit All Terrain  
**REAR DERAILLEUR** Shimano Deore RD-M6000-DGS, ShadowPlus, 10-Speed  
**SHIFTERS** Shimano Deore SL-M6000, Rapidfire-Plus  
**BRAKE SYSTEMS** Shimano BR-MT400, Hydr. Disc Brake (180/160)  
**CRANKSET** SA CK-602, 38T, 175mm  
**CASSETTE** Shimano Deore CS-HG500, 11-42T  
**CHAIN** MC X10  
**RIMS** CUBE EX23, 36H, Disc, Tubeless Ready  
**FRONT HUB** Shimano HB-TX505, QR, Centerlock  
**REAR HUB** Shimano FH-TX505, QR, Centerlock  
**TYRES** Schwalbe Smart Sam, Active, 44-622  
**PEDALS** CUBE PP MTB  
**SADDLE** Natural Fit Sequence+ Comfort  
**SEAT POST** CUBE Performance Post, 27.2mm  
**SEATCLAMP** CUBE Varioclose, 31.8mm  
**FRONT LIGHT** AXA Compactline 20, 6-12V, DC  
**REAR LIGHT** Busch & Müller Xeltec, DC  
**KICKSTAND** CUBEstand Cmp  
**MUDGUARDS** CID 53  
**BELL** Mini Bell

**SPARE PARTS**  
**10149** CUBE Hanger #149 long version  
**10338** CUBE Headset Orbit 1.5E ZS 1 1/8 / 1.5 semi + 1 1/8 crown race

**WEIGHT** #1,4 kg



11027

CUBE AM JERSEY



10688

CUBE AM BAGGY SHORTS



11069

CUBE GLOVES PERFORMANCE

# NATURE HYBRID ONE ALLROAD

iridium'n'blue



# NATURE HYBRID ONE ALLROAD

red'n'red



Trapeze | iridium'n'blue



Trapeze | red'n'red



One bike, many reasons: The Nature Hybrid ONE Allroad is the Bosch e-bike that'll slot right into your life. Fully equipped with mudguards, an AXA and Busch & Müller lighting system that runs off the Bosch battery and a kickstand, it's ready to go wherever you go. So neatly integrated is the Bosch motor and battery, many people won't even spot that you're riding an e-bike – and they're protected from the elements, too. Choose the 400Wh battery for everyday use, or the more powerful 500Wh version for extended range. There's no need to remove the battery for charging, and features like a tapered head tube and double-butted frame tubes contribute to a frame that's strong and durable enough to pass our in-house safety tests with flying colours. Grippy Schwalbe Smart Sam tyres and powerful Shimano hydraulic disc brakes ensure you're always in full control, while the Suntour suspension fork tackles the rough surfaces and potholes of modern urban riding with ease. Star of the show, though, is undoubtedly the reliable and smooth Bosch drive unit. Feeding both your and the motor's power to the rear wheel via slick Shimano gears, it makes every ride a pleasure. And, with a trapeze frame option and a wide range of sizes, we've got every rider covered. From city street to country lane, it's the ideal two-wheeled companion.

- ★ **330111** Cube Nature Hybrid ONE 500 Allroad red'n'red 2020
- 330110** Cube Nature Hybrid ONE 400 Allroad red'n'red 2020
- 330101** Cube Nature Hybrid ONE 500 Allroad iridium'n'blue 2020
- 330100** Cube Nature Hybrid ONE 400 Allroad iridium'n'blue 2020

**FRAME** Aluminium Superlite, Comfort, Full Integrated Battery, Double Butted  
**SIZE** Men: 50, 54, 58, 62; Trapeze: 46, 50, 54  
**FORK** Suntour NEX-E25, 63mm

**DRIVE UNIT** Bosch Drive Unit Active Plus Generation 3 (50Nm) Cruise (250Watt)  
**BATTERY** Bosch PowerPack 500  
**DISPLAY** Bosch Purion  
**CHARGER** Bosch 2A

**HEADSET** SA Orbit 1.5B ZS-R, Top Zero-Stack 1 1/8" (OD 44mm), Bottom Zero-Stack 1 1/2" (OD 56mm)  
**STEM** CUBE Performance Stem Pro, 31.8mm  
**HANDLEBAR** CUBE Rise Trail Bar, 700mm  
**GRIPS** CUBE Performance Grip  
**REAR DERAILLEUR** Shimano RD-M4000-SGS, 9-Speed  
**SHIFTERS** Shimano SL-M2010-9R, Rapidfire-Plus  
**BRAKE SYSTEM** Shimano BR-MT200, Hydr. Disc Brake (180/160)  
**CRANKSET** SA CK-602, 38T, 175mm  
**CASSETTE** Shimano CS-HG201, 11-36T  
**CHAIN** KMC X9  
**RIMS** CUBE EX23, 36H, Disc, Tubeless Ready  
**FRONT HUB** Shimano HB-TX505, QR, Centerlock  
**REAR HUB** Shimano FH-TX505, QR, Centerlock  
**TYRES** Schwalbe Smart Sam, Active, 44-622  
**PEDALS** CUBE PP MTB  
**SADDLE** Natural Fit Sequence Comfort  
**SEAT POST** CUBE Performance Post, 27.2mm  
**SEATCLAMP** CUBE Varioclose, 31.8mm  
**FRONT LIGHT** AXA Compactline 20, 6-12V, DC  
**REAR LIGHT** Busch & Müller Xeltec, DC  
**KICKSTAND** CUBEstand Cmp  
**MUDGUARDS** ACD 53  
**BELL** Mini Bell

**SPARE PARTS**  
**10148** CUBE Hanger #148 short version  
**10338** CUBE Headset Orbit 1.5E ZS 1 1/8 / 1.5 semi + 1 1/8 crown race

**WEIGHT** #2,2 kg



11059

CUBE JERSEY ACTIVE



11408

CUBE BAGGY SHORTS ACTIVE



16180

CUBE HELMET STEEP



---

## FOR us #Explorers

---

The Kathmandu Hybrid carries with it a deserved reputation for versatility, durability and comfort. Completely redesigned around Bosch's superb new fourth-generation CX drive unit for 2020, we've built on this solid foundation with a new frame that's better looking, more practical and easier to live with than ever. The heart of the new frame is the gravity cast down tube with new Modular Battery System. Protected behind an easily accessed cover, the Bosch power unit fits tidily within the Kathmandu Hybrid's sleek frame, leaving plenty of space for bottle cage mounts and the option of a larger capacity battery for extended range. The new Integrated Carrier 2.0 provides the most stable platform possible for carrying your gear, whilst complementing the frame's clean lines and boasting replaceable wear components – so you're assured of a long service life. The tapered head tube assures accurate steering from the 100mm suspension fork, internal cable routing keeps gear shifts clean and precise with no need for regular maintenance, and we even included a neatly integrated kickstand mount. As every keen traveller knows, the secret to success lies in the details.



# KATHMANDU HYBRID SLT

Trapeze | teak 'n' silver



Easy Entry | teak 'n' silver



# KATHMANDU HYBRID SLT

teak 'n' silver



There are times in life when it's just not worth compromising. When our design team set out to build the brand-new Kathmandu Hybrid SLT, that was their mantra: no compromise. So, as well as Bosch's fourth-generation CX drive unit, you'll find a full complement of Shimano XT 12-speed components for unmatched gear range and smooth, reliable shifting – every time. There's a matching pair of Shimano XT four-piston hydraulic disc brakes, for powerful and dependable stopping in any weather conditions. A RockShox Judy Gold Air suspension fork – developed for the demands of mountain biking – with 100mm of easy-to-adjust travel to smooth out the road ahead. And a full complement of practical, durable accessories from full-length mudguards, integrated light set – with 180 lumen sidelight, for even better visibility – and kickstand. Star of the show, of course, is the Bosch CX motor and new CUBE Modular Battery System, both of which sit unobtrusively inside our new, mountain bike-inspired Kathmandu frameset. Sleek, stiff and more than strong enough to pass our in-house torture testing with flying colours, it's full of the neat touches that are the hallmarks of CUBE frame design. Internal cable routing keeps your gears shifting smoothly for longer, with minimal maintenance. The tapered head tube works with the suspension fork's thru-axle to deliver impeccably accurate, intuitive steering even with a full load. And the built-in Integrated Carrier 2.0 is the neatest, stiffest and strongest way to use your Bosch e-bike as a load carrier, whether you're tackling a daily commute, running to the shops or planning a multi-day tour. The Kathmandu Hybrid SLT is ready for anything, and available in Easy Entry, Trapeze or Men's frame options. All you need to do is jump on... and ride.

**SPARE PARTS#**  
**10148** CUBE Hanger #148 short version  
**10338** CUBE Headset Orbit 1.5E ZS 1 1/8 / 1.5 semi + 1 1/8 crown race

★ **331352** Cube Kathmandu Hybrid SLT 625 teak 'n' silver 2020

**FRAME#** Aluminum Superlite, Gravity Casting Technology, Efficient Comfort Geometry, Tapered Headtube, Full Integrated Battery, Integrated Carrier 2.0  
**SIZE#** Men: 50, 54, 58, 62; Trapeze: 46, 50, 54; Easy Entry: 46, 50, 54, 58  
**FORK#** RockShox Judy Gold RL Air, Tapered, 15x110mm, 100mm, Lockout

**DRIVE UNIT#** Bosch Drive Unit Performance CX Generation 4 (75Nm) Cruise (250Watt)  
**BATTERY#** Bosch PowerTube 625  
**DISPLAY#** Bosch Kiox  
**CHARGER#** Bosch 4A

**HEADSET#** SA 1.5E ZS, Tapered, Top Zero-Stack 1 1/8" (OD 44mm), Bottom Zero-Stack 1 1/2" (OD 56mm)  
**STEM#** Satori Up2 Plus, 31.8mm, Adjustable  
**HANDLEBAR#** CUBE Rise Trail Bar, 700mm  
**GRIPS#** Natural Fit Comfort  
**REAR DERAILLEUR#** Shimano XT RD-M8100-SGS, ShadowPlus, 12-Speed  
**SHIFTERS#** Shimano XT SL-M8100-IR, Direct Attach  
**BRAKE SYSTEM#** Shimano XT BR-M8120, Hydr. Disc Brake (180/180)  
**CRANKSET#** CID E-Crank, 38T, 175mm  
**CASSETTE#** Shimano XT CS-M8100, 10-51T  
**CHAIN#** Shimano XT CN-M8100  
**RIMS#** CUBE EX23, 36H, Disc, Tubeless Ready  
**FRONT HUB#** Shimano HB-MT400-B, 15mm, Boost, Centerlock  
**REAR HUB#** Shimano FH-MT500, QR, Centerlock  
**TYRES#** Schwalbe Marathon E-Plus, 55-622  
**PEDALS#** CUBE PP MTB  
**SADDLE#** Natural Fit Sequence+ Comfort  
**SEAT POST#** R Suntour NCX Suspension Seatpost, 30.9mm  
**SEATCLAMP#** CUBE Varioclose, 34.9mm  
**FRONT LIGHT#** Herrmans H-Black MR8, 6-12V, DC  
**REAR LIGHT#** Herrmans H-Trace  
**KICKSTAND#** CUBEstand Pro, Adjustable  
**MUDGUARDS#** CID 65  
**BELL#** nog Oi  
**CARRIER#** CUBE Integrated Carrier 2.0, CUBE Adapter Compatible, SnapIt Compatible and Rail

**WEIGHT#** 6,3 kg

# KATHMANDU HYBRID SL

Trapeze | black 'n' blue



# KATHMANDU HYBRID SL

black 'n' blue



Easy Entry | black 'n' blue



Ready to step up to a Bosch e-bike that's fully equipped for anything life can throw at you? Allow us to introduce the brand-new Kathmandu Hybrid SL – a touring hybrid that resets your expectations of what a bike like this can achieve. Built from the ground up around the fourth-generation Bosch CX drive unit – now smaller and lighter than ever – and our exclusive CUBE Modular Battery System, the Kathmandu Hybrid SL's sleek lines disguise a wealth of clever attention to detail. Whether it's the high-capacity battery that can be charged in-frame, the tapered head tube for more accurate steering, or the incredibly neat, stiff and strong Integrated Carrier 2.0 for carrying all your essentials, we've ploughed everything we've learnt about building class-leading e-mountain bikes into a hybrid tourer that's tougher, better to ride and more versatile than ever. The RockShox Judy Silver Air fork has 100mm of easily adjustable travel to help smooth out the roughest of road surfaces, while Shimano's slick and reliable 12-speed XT and SLX transmission gives an unparalleled gear range to help keep your pedals turning even on the steepest of hills. Wide CUBE rims shod with tough, durable and grippy Marathon E-Plus tyres work in conjunction with Shimano's powerful hydraulic disc brake system to put you in control at all times. And full-length mudguards, a CUBE kickstand and integrated lighting system ensure you're fully equipped from the moment you leave your CUBE dealer. It's got everything you need to transport you, your belongings and your spirit of adventure across town, cross country or even, if you fancy it, across a continent. Go. Explore.

- SPARE PARTS#**
- 10148** CUBE Hanger #148 short version
  - 10338** CUBE Headset Orbit 1.5E ZS 1 1/8 / 1.5 semi + 1 1/8 crown race

★ **331302** Cube Kathmandu Hybrid SL 625 black 'n' blue 2020

**FRAME#** Aluminum Superlite, Gravity Casting Technology, Efficient Comfort Geometry, Tapered Headtube, Full Integrated Battery, Integrated Carrier 2.0  
**SIZE#** Men: 50, 54, 58, 62; Trapeze: 46, 50, 54; Easy Entry: 46, 50, 54, 58  
**FORK#** RockShox Judy Silver TK Air, Tapered, 15x110mm, 100mm, Lockout

**DRIVE UNIT#** Bosch Drive Unit Performance CX Generation 4 (75Nm) Cruise (250Watt)  
**BATTERY#** Bosch PowerTube 625  
**DISPLAY#** Bosch Kiox  
**CHARGER#** Bosch 4A

**HEADSET#** SA 1.5E ZS, Tapered, Top Zero-Stack 1 1/8" (OD 44mm), Bottom Zero-Stack 1 1/2" (OD 56mm)  
**STEM#** Satori Up2 Plus, 31.8mm, Adjustable  
**HANDLEBAR#** CUBE Rise Trail Bar, 700mm  
**GRIPS#** Natural Fit Comfort  
**REAR DERAILLEUR#** Shimano XT RD-M8100-SGS, ShadowPlus, 12-Speed  
**SHIFTERS#** Shimano SLX SL-M7100  
**BRAKE SYSTEM#** Shimano BR-MT520/BR-MT500, Hydr. Disc Brake (180/180)  
**CRANKSET#** CID E-Crank, 34T, 165mm  
**CASSETTE#** Shimano SLX CS-M7100, 10-51T  
**CHAIN#** Shimano SLX CN-M7100  
**RIMS#** CUBE EX23, 36H, Disc, Tubeless Ready  
**FRONT HUB#** Shimano HB-MT400-B, 15mm, Boost, Centerlock  
**REAR HUB#** Shimano FH-MT500, QR, Centerlock  
**TYRES#** Schwalbe Marathon E-Plus, 55-622  
**PEDALS#** CUBE PP MTB  
**SADDLE#** Natural Fit Sequence+ Comfort  
**SEAT POST#** CUBE Suspension Seatpost, 30.9mm  
**SEATCLAMP#** CUBE Varioclose, 34.9mm  
**FRONT LIGHT#** Herrmans H-Black MR8, 6-12V, DC  
**REAR LIGHT#** Herrmans H-Trace  
**KICKSTAND#** CUBEstand Cmpst  
**MUDGUARDS#** CID 65  
**BELL#** Mini Bell  
**CARRIER#** CUBE Integrated Carrier 2.0, CUBE Adapter Compatible, SnapIt Compatible and Rail

**WEIGHT#** 6,4 kg



# KATHMANDU HYBRID EXC

Trapeze | green 'n' green



# KATHMANDU HYBRID EXC

green 'n' green



Easy Entry | green 'n' green



Whatever you're looking for in an urban Bosch e-bike, you'll find it in the brand-new Kathmandu Hybrid EXC. We've taken all the experience gained from designing some of the world's best e-mountain bikes and poured it into this versatile, sure-footed and adaptable tourer. From the steering-enhancing tapered head tube to the strong, rigid Integrated Carrier 2.0, every detail is aimed at making the Kathmandu Hybrid EXC a reliable, versatile two-wheeled companion. Built around Bosch's smaller, lighter, fourth-generation CX drive unit and a brand-new CUBE Modular Battery System, the frame's sleek appearance disguises the huge amount of time that's gone into designing and testing it. Internal cable routing keeps the Shimano 11-speed transmission shifting smoothly with minimal maintenance, whilst the huge gear range and seamless power delivery from the Bosch drive system ensure that you can tackle any road with ease. The battery can be recharged in situ, and there's a choice of powerful 500Wh or 625Wh units for extended range. The mountain bike-inspired Suntour suspension fork has an easily adjustable air spring and 100mm of smooth, pothole-swallowing travel – and we even added a suspension seat post to keep you comfortably seated even on long days out. Tough, grippy Schwalbe e-bike specific tyres work with powerful Shimano hydraulic discs to keep you in control whatever the weather, and of course full-length mudguards, a kickstand and integrated lighting system mean that 'fully equipped' isn't just a marketing slogan. Where are you going tomorrow? Because one thing's for sure: the Kathmandu Hybrid EXC will get you there in style, in comfort and with a smile on your face.



### SPARE PARTS#

- 10148** CUBE Hanger #148 short version
- 10338** CUBE Headset Orbit 1.5E ZS 1 1/8 / 1.5 semi + 1 1/8 crown race



- 331262** Cube Kathmandu Hybrid EXC 625 green 'n' green 2020
- 331261** Cube Kathmandu Hybrid EXC 500 green 'n' green 2020



- FRAME#** Aluminum Superlite, Gravity Casting Technology, Efficient Comfort Geometry, Tapered Headtube, Full Integrated Battery, Integrated Carrier 2.0
- SIZE#** Men: 50, 54, 58, 62; Trapeze: 46, 50, 54; Easy Entry: 46, 50, 54, 58
- FORK#** Suntour XCR32 LO-R Air, 100mm, Lockout



- DRIVE UNIT#** Bosch Drive Unit Performance CX Generation 4 (75Nm) Cruise (250Watt)
- BATTERY#** Bosch PowerTube 625
- DISPLAY#** Bosch Intuvia
- CHARGER#** Bosch 2A



- HEADSET#** SA Orbit 1.5B ZS-R, Top Zero-Stack 1 1/8" (OD 44mm), Bottom Zero-Stack 1 1/2" (OD 56mm)
- STEM#**atori Up2 Plus, 31.8mm, Adjustable
- HANDLEBAR#**CUBE Rise Trail Bar, 700mm
- GRIPS#**Natural Fit Comfort
- REAR DERAILLEUR#**Shimano XT RD-M8000-GS, ShadowPlus, 11-Speed
- SHIFTERS#**Shimano SLX SL-M7000
- BRAKE SYSTEM#**Shimano BR-MT420/MT400, Hydr. Disc Brake (180/180)
- CRANKSET#**ACID E-Crank, 38T, 175mm
- CASSETTE#**Shimano SLX CS-M7000, 11-46T
- CHAIN#**MC X11
- RIMS#**CUBE EX23, 36H, Disc, Tubeless Ready
- FRONT HUB#**Shimano Deore HB-M6000, QR, Centerlock
- REAR HUB#**Shimano Deore FH-M6000, QR, Centerlock
- TYRES#**Schwalbe Marathon E-Plus, 55-622
- PEDALS#**CUBE PP MTB
- SADDLE#**Natural Fit Sequence+ Comfort
- SEAT POST#**CUBE Suspension Seatpost, 30.9mm
- SEATCLAMP#**CUBE Varioclose, 34.9mm
- FRONT LIGHT#**Herrmans H-Black MR4, 6-12V, DC
- REAR LIGHT#**Herrmans H-Trace
- KICKSTAND#**CUBEstand Cmp
- MUDGUARDS#**ACID 65
- BELL#**Mini Bell
- CARRIER#**CUBE Integrated Carrier 2.0, CUBE Adapter Compatible, SnapIt Compatible and Rail



**WEIGHT#**6,5 kg



# KATHMANDU HYBRID EXC

Trapeze | iridium'n' red



# KATHMANDU HYBRID EXC

iridium'n' red



Easy Entry | iridium'n' red



Whatever you're looking for in an urban Bosch e-bike, you'll find it in the brand-new Kathmandu Hybrid EXC. We've taken all the experience gained from designing some of the world's best e-mountain bikes and poured it into this versatile, sure-footed and adaptable tourer. From the steering-enhancing tapered head tube to the strong, rigid Integrated Carrier 2.0, every detail is aimed at making the Kathmandu Hybrid EXC a reliable, versatile two-wheeled companion. Built around Bosch's smaller, lighter, fourth-generation CX drive unit and a brand-new CUBE Modular Battery System, the frame's sleek appearance disguises the huge amount of time that's gone into designing and testing it. Internal cable routing keeps the Shimano 11-speed transmission shifting smoothly with minimal maintenance, whilst the huge gear range and seamless power delivery from the Bosch drive system ensure that you can tackle any road with ease. The battery can be recharged in situ, and there's a choice of powerful 500Wh or 625Wh units for extended range. The mountain bike-inspired Suntour suspension fork has an easily adjustable air spring and 100mm of smooth, pothole-swallowing travel – and we even added a suspension seat post to keep you comfortably seated even on long days out. Tough, grippy Schwalbe e-bike specific tyres work with powerful Shimano hydraulic discs to keep you in control whatever the weather, and of course full-length mudguards, a kickstand and integrated lighting system mean that 'fully equipped' isn't just a marketing slogan. Where are you going tomorrow? Because one thing's for sure: the Kathmandu Hybrid EXC will get you there in style, in comfort and with a smile on your face.

- ★ **331252** Cube Kathmandu Hybrid EXC 625 iridium'n' red 2020
- ★ **331251** Cube Kathmandu Hybrid EXC 500 iridium'n' red 2020

**FRAME** Aluminum Superlite, Gravity Casting Technology, Efficient Comfort Geometry, Tapered Headtube, Full Integrated Battery, Integrated Carrier 2.0  
**SIZE** Men: 50, 54, 58, 62; Trapeze: 46, 50, 54; Easy Entry: 46, 50, 54, 58  
**FORK** R Suntour XCR32 LO-R Air, 100mm, Lockout

**DRIVE UNIT** Bosch Drive Unit Performance CX Generation 4 (75Nm) Cruise (250Watt)  
**BATTERY** Bosch PowerTube 625  
**DISPLAY** Bosch Intuvia  
**CHARGER** Bosch 2A

**HEADSET** SA Orbit 1.5B ZS-R, Top Zero-Stack 1 1/8" (OD 44mm), Bottom Zero-Stack 1 1/2" (OD 56mm)  
**STEM**atori Up2 Plus, 31.8mm, Adjustable  
**HANDLEBAR** CUBE Rise Trail Bar, 700mm  
**GRIPS** Natural Fit Comfort  
**REAR DERAILLEUR** Shimano XT RD-M8000-GS, ShadowPlus, 11-Speed  
**SHIFTERS** Shimano SLX SL-M7000  
**BRAKE SYSTEM** Shimano BR-MT420/MT400, Hydr. Disc Brake (180/180)  
**CRANKSET** CID E-Crank, 38T, 175mm  
**CASSETTE** Shimano SLX CS-M7000, 11-46T  
**CHAIN** MC X11  
**RIMS** CUBE EX23, 36H, Disc, Tubeless Ready  
**FRONT HUB** Shimano Deore HB-M6000, QR, Centerlock  
**REAR HUB** Shimano Deore FH-M6000, QR, Centerlock  
**TYRES** Schwalbe Marathon E-Plus, 55-622  
**PEDALS** CUBE PP MTB  
**SADDLE** Natural Fit Sequence+ Comfort  
**SEAT POST** CUBE Suspension Seatpost, 30.9mm  
**SEATCLAMP** CUBE Varioclose, 34.9mm  
**FRONT LIGHT** Herrmans H-Black MR4, 6-12V, DC  
**REAR LIGHT** Herrmans H-Trace  
**KICKSTAND** CUBEstand Cmp  
**MUDGUARDS** CID 65  
**BELL** Mini Bell  
**CARRIER** CUBE Integrated Carrier 2.0, CUBE Adapter Compatible, SnapIt Compatible and Rail

**SPARE PARTS#**  
**10148** CUBE Hanger #148 short version  
**10338** CUBE Headset Orbit 1.5E ZS 1 1/8 / 1.5 semi + 1 1/8 crown race

**WEIGHT** #6,5 kg

# KATHMANDU HYBRID PRO

Trapeze | grey'n'orange



# KATHMANDU HYBRID PRO

grey'n'orange



Easy Entry | grey'n'orange



If there's one bike in the CUBE range that symbolises the freedom of two-wheeled exploration, it's this: the brand-new Kathmandu Hybrid Pro. Whether you're an occasional commuter or regular cyclist; whether you ride to get around the city or to escape into the countryside at the weekends, this is a bike to feed your sense of adventure. With a completely revised frame and new, fourth-generation Bosch CX drive unit mated to Shimano's reliable 10-speed Deore transmission, our design team pulled out all the stops to create an adaptable, versatile ride companion. From the Integrated Carrier 2.0 to the tapered head tube and fully enclosed, CUBE Modular Battery System, every detail of the Kathmandu Hybrid Pro's chassis is designed for strength, stiffness and durability – a fact that we've proved in our in-house test lab. And, with a choice of Easy Entry, Trapeze or Men's frames, there's a Kathmandu Hybrid Pro to suit any rider. But it's not just about function, because it wouldn't be a CUBE Hybrid if it didn't also have elegant lines and incredibly easy, intuitive handling thanks to its low centre of gravity. With a tough Suntour suspension fork featuring 100mm of travel and a suspension seat post too, you're assured of a comfortable ride on even the roughest of road surfaces. Grippy Schwalbe tyres and powerful Shimano hydraulic disc brakes ensure that you always have full control, no matter what the weather. And practical touches like the full-length mudguards, integrated lighting system and CUBE kickstand mean you're fully equipped for wherever your busy life – or your curiosity – takes you. We've thought of everything, so you can just enjoy the ride.



#### SPARE PARTS#

- 10148** CUBE Hanger #148 short version
- 10338** CUBE Headset Orbit 1.5E ZS 1 1/8 / 1.5 semi + 1 1/8 crown race



- 331212** Cube Kathmandu Hybrid Pro 625 grey'n'orange 2020
- 331211** Cube Kathmandu Hybrid Pro 500 grey'n'orange 2020



- FRAME#** Aluminum Superlite, Gravity Casting Technology, Efficient Comfort Geometry, Tapered Headtube, Full Integrated Battery, Integrated Carrier 2.0
- SIZE#** Men: 50, 54, 58, 62; Trapeze: 46, 50, 54; Easy Entry: 46, 50, 54, 58
- FORK#** Suntour XCM ATB Coil, 100mm



- DRIVE UNIT#** Bosch Drive Unit Performance CX Generation 4 (75Nm) Cruise (250Watt)
- BATTERY#** Bosch PowerTube 625
- DISPLAY#** Bosch Intuvia
- CHARGER#** Bosch 2A



- HEADSET#** SA Orbit 1.5B ZS-R, Top Zero-Stack 1 1/8" (OD 44mm), Bottom Zero-Stack 1 1/2" (OD 56mm)
- STEM#**atori Up2 Plus, 31.8mm, Adjustable
- HANDLEBAR#**CUBE Rise Trail Bar, 700mm
- GRIPS#**Natural Fit Comfort
- REAR DERAILLEUR#**Shimano Deore RD-M6000-GS, 10-Speed
- SHIFTERS#**Shimano Deore SL-M6000, Rapidfire-Plus
- BRAKE SYSTEM#**Shimano BR-MT200, Hydr. Disc Brake (180/180)
- CRANKSET#**ACID E-Crank, 38T, 175mm
- CASSETTE#**Shimano Deore CS-HG500, 11-42T
- CHAIN#**MC X10
- RIMS#**CUBE EX23, 36H, Disc, Tubeless Ready
- FRONT HUB#**Shimano HB-TX505, QR, Centerlock
- REAR HUB#**Shimano FH-TX505, QR, Centerlock
- TYRES#**Schwalbe Big Ben, Performance, 55-622
- PEDALS#**CUBE PP MTB
- SADDLE#**Natural Fit Sequence Comfort
- SEAT POST#**CUBE Suspension Seatpost, 30.9mm
- SEATCLAMP#**CUBE Varioclose, 34.9mm
- FRONT LIGHT#**CUBE Shiny 50 Lux, 6-12V, DC
- REAR LIGHT#**CUBE IC 2.0 Rear LED, 6-12V, DC
- KICKSTAND#**CUBEstand Cmp
- MUDGUARDS#**ACID 65
- BELL#**Mini Bell
- CARRIER#**CUBE Integrated Carrier 2.0, CUBE Adapter Compatible, SnapIt Compatible and Rail



**WEIGHT#**5.9 kg



# KATHMANDU HYBRID PRO

Trapeze | black 'n' white



# KATHMANDU HYBRID PRO

black 'n' white



Easy Entry | black 'n' white



If there's one bike in the CUBE range that symbolises the freedom of two-wheeled exploration, it's this: the brand-new Kathmandu Hybrid Pro. Whether you're an occasional commuter or regular cyclist; whether you ride to get around the city or to escape into the countryside at the weekends, this is a bike to feed your sense of adventure. With a completely revised frame and new, fourth-generation Bosch CX drive unit mated to Shimano's reliable 10-speed Deore transmission, our design team pulled out all the stops to create an adaptable, versatile ride companion. From the Integrated Carrier 2.0 to the tapered head tube and fully enclosed, CUBE Modular Battery System, every detail of the Kathmandu Hybrid Pro's chassis is designed for strength, stiffness and durability – a fact that we've proved in our in-house test lab. And, with a choice of Easy Entry, Trapeze or Men's frames, there's a Kathmandu Hybrid Pro to suit any rider. But it's not just about function, because it wouldn't be a CUBE Hybrid if it didn't also have elegant lines and incredibly easy, intuitive handling thanks to its low centre of gravity. With a tough Suntour suspension fork featuring 100mm of travel and a suspension seat post too, you're assured of a comfortable ride on even the roughest of road surfaces. Grippy Schwalbe tyres and powerful Shimano hydraulic disc brakes ensure that you always have full control, no matter what the weather. And practical touches like the full-length mudguards, integrated lighting system and CUBE kickstand mean you're fully equipped for wherever your busy life – or your curiosity – takes you. We've thought of everything, so you can just enjoy the ride.

- SPARE PARTS#**
- 10148** CUBE Hanger #148 short version
  - 10338** CUBE Headset Orbit 1.5E ZS 1 1/8 / 1.5 semi + 1 1/8 crown race

- ★ **331202** Cube Kathmandu Hybrid Pro 625 black 'n' white 2020
- ★ **331201** Cube Kathmandu Hybrid Pro 500 black 'n' white 2020

**FRAME#** Aluminum Superlite, Gravity Casting Technology, Efficient Comfort Geometry, Tapered Headtube, Full Integrated Battery, Integrated Carrier 2.0  
**SIZE#** Men: 50, 54, 58, 62; Trapeze: 46, 50, 54; Easy Entry: 46, 50, 54, 58  
**FORK#** Suntour XCM ATB Coil, 100mm

**DRIVE UNIT#** Bosch Drive Unit Performance CX Generation 4 (75Nm) Cruise (250Watt)  
**BATTERY#** Bosch PowerTube 625  
**DISPLAY#** Bosch Intuvia  
**CHARGER#** Bosch 2A

**HEADSET#** SA Orbit 1.5B ZS-R, Top Zero-Stack 1 1/8" (OD 44mm), Bottom Zero-Stack 1 1/2" (OD 56mm)  
**STEM#**atori Up2 Plus, 31.8mm, Adjustable  
**HANDLEBAR#**CUBE Rise Trail Bar, 700mm  
**GRIPS#**Natural Fit Comfort  
**REAR DERAILLEUR#**Shimano Deore RD-M6000-GS, 10-Speed  
**SHIFTERS#**Shimano Deore SL-M6000, Rapidfire-Plus  
**BRAKE SYSTEM#**Shimano BR-MT200, Hydr. Disc Brake (180/180)  
**CRANKSET#**ACID E-Crank, 38T, 175mm  
**CASSETTE#**Shimano Deore CS-HG500, 11-42T  
**CHAIN#**MC X10  
**RIMS#**CUBE EX23, 36H, Disc, Tubeless Ready  
**FRONT HUB#**Shimano HB-TX505, QR, Centerlock  
**REAR HUB#**Shimano FH-TX505, QR, Centerlock  
**TYRES#**Schwalbe Big Ben, Performance, 55-622  
**PEDALS#**CUBE PP MTB  
**SADDLE#**Natural Fit Sequence Comfort  
**SEAT POST#**CUBE Suspension Seatpost, 30.9mm  
**SEATCLAMP#**CUBE Varioclose, 34.9mm  
**FRONT LIGHT#**CUBE Shiny 50 Lux, 6-12V, DC  
**REAR LIGHT#**CUBE IC 2.0 Rear LED, 6-12V, DC  
**KICKSTAND#**CUBEstand Cmp  
**MUDGUARDS#**ACID 65  
**BELL#**Mini Bell  
**CARRIER#**CUBE Integrated Carrier 2.0, CUBE Adapter Compatible, SnapIt Compatible and Rail

**WEIGHT#**5.9 kg

# KATHMANDU HYBRID ONE

Trapeze | blue'n'yellow



Easy Entry | blue'n'yellow



# KATHMANDU HYBRID ONE

blue'n'yellow



The spirit of adventure doesn't come with a price tag attached. That's why we developed the Kathmandu Hybrid ONE – a truly affordable, fourth-generation Bosch-powered touring e-bike that's designed specifically for the curious of mind. Go wherever your imagination leads you, take what you need with you, and explore new horizons. With its strong, rigid Integrated Carrier 2.0 and advanced frame design, the Kathmandu Hybrid ONE is the reliable companion you'll need on your two-wheeled journeys. Based around our new Modular Battery System, the elegant down tube has ample room for the Bosch PowerTube, hidden behind an easily accessed cover. The new design isn't just exceptionally neat – it also meant our engineers could offer the option of a larger capacity battery for even more range, while still leaving room for bottle cage mounts. The included CUBE kickstand frees you from finding a 'convenient' wall or tree on which to rest your bike, while full-length mudguards help keep you drier on wet roads and the lights allow you to see and be seen, regardless of how late in the day you end up riding. The Suntour suspension fork, combined with wide Schwalbe tyres, smooths out even the bumpiest of roads. And easy-to-use, reliable Shimano 9-speed gears work seamlessly with the Bosch drive system to boost your pedalling and make every ride and every hill that little bit easier. We even fitted powerful Shimano hydraulic disc brakes for safe, assured stopping in any weather conditions. Our goal was to sweat the details, so you can just jump on and ride wherever your spirit of adventure demands. Because life's too short to be saying, 'one day, I'll get around to doing that ride'. Do it now. Do it with the Kathmandu Hybrid ONE.



## SPARE PARTS#

- 10148** CUBE Hanger #148 short version
- 10338** CUBE Headset Orbit 1.5E ZS 1 1/8 / 1.5 semi + 1 1/8 crown race



- 331182** Cube Kathmandu Hybrid ONE 625 blue'n'yellow 2020
- 331181** Cube Kathmandu Hybrid ONE 500 blue'n'yellow 2020



- FRAME#** Aluminum Superlite, Gravity Casting Technology, Efficient Comfort Geometry, Tapered Headtube, Full Integrated Battery, Integrated Carrier 2.0
- SIZE#** Men: 50, 54, 58, 62; Trapeze: 46, 50, 54; Easy Entry: 46, 50, 54, 58
- FORK#** Suntour XCM ATB Coil, 100mm



- DRIVE UNIT#** Bosch Drive Unit Performance CX Generation 4 (75Nm) Cruise (250Watt)
- BATTERY#** Bosch PowerTube 625
- DISPLAY#** Bosch Purion
- CHARGER#** Bosch 2A



- HEADSET#** SA Orbit 1.5B ZS-R, Top Zero-Stack 1 1/8" (OD 44mm), Bottom Zero-Stack 1 1/2" (OD 56mm)
- STEM#** CUBE Performance Stem Pro, 31.8mm
- HANDLEBAR#** CUBE Rise Trail Bar, 700mm
- GRIPS#** CUBE Performance Grip
- REAR DERAILLEUR#** Shimano RD-M2000-SGS, 9-Speed
- SHIFTERS#** Shimano SL-M2010-9R, Rapidfire-Plus
- BRAKE SYSTEM#** Shimano BR-MT200, Hydr. Disc Brake (180/180)
- CRANKSET#** CID E-Crank, 38T, 175mm
- CASSETTE#** Shimano CS-HG201, 11-36T
- CHAIN#** MC X9
- RIMS#** CUBE EX23, 36H, Disc, Tubeless Ready
- FRONT HUB#** Shimano HB-TX505, QR, Centerlock
- REAR HUB#** Shimano FH-TX505, QR, Centerlock
- TYRES#** Schwalbe Big Ben, Performance, 55-622
- PEDALS#** CUBE PP MTB
- SADDLE#** Natural Fit Sequence Comfort
- SEAT POST#** CUBE Performance Post, 30.9mm
- SEATCLAMP#** CUBE Varioclose, 34.9mm
- FRONT LIGHT#** CUBE Shiny 50 Lux, 6-12V, DC
- REAR LIGHT#** CUBE IC 2.0 Rear LED, 6-12V, DC
- KICKSTAND#** CUBEstand Cmp
- MUDGUARDS#** CID 65
- BELL#** Mini Bell
- CARRIER#** CUBE Integrated Carrier 2.0, CUBE Adapter Compatible, SnapIt Compatible and Rail



**WEIGHT#** 5,5 kg



# KATHMANDU HYBRID ONE

Trapeze | black 'n' grey



EasyEntry | black 'n' grey



# KATHMANDU HYBRID ONE

black 'n' grey



The spirit of adventure doesn't come with a price tag attached. That's why we developed the Kathmandu Hybrid ONE – a truly affordable, fourth-generation Bosch-powered touring e-bike that's designed specifically for the curious of mind. Go wherever your imagination leads you, take what you need with you, and explore new horizons. With its strong, rigid Integrated Carrier 2.0 and advanced frame design, the Kathmandu Hybrid ONE is the reliable companion you'll need on your two-wheeled journeys. Based around our new Modular Battery System, the elegant down tube has ample room for the Bosch PowerTube, hidden behind an easily accessed cover. The new design isn't just exceptionally neat – it also meant our engineers could offer the option of a larger capacity battery for even more range, while still leaving room for bottle cage mounts. The included CUBE kickstand frees you from finding a 'convenient' wall or tree on which to rest your bike, while full-length mudguards help keep you drier on wet roads and the lights allow you to see and be seen, regardless of how late in the day you end up riding. The Suntour suspension fork, combined with wide Schwalbe tyres, smooths out even the bumpiest of roads. And easy-to-use, reliable Shimano 9-speed gears work seamlessly with the Bosch drive system to boost your pedalling and make every ride and every hill that little bit easier. We even fitted powerful Shimano hydraulic disc brakes for safe, assured stopping in any weather conditions. Our goal was to sweat the details, so you can just jump on and ride wherever your spirit of adventure demands. Because life's too short to be saying, 'one day, I'll get around to doing that ride'. Do it now. Do it with the Kathmandu Hybrid ONE.

- SPARE PARTS#**
- 10148** CUBE Hanger #148 short version
  - 10338** CUBE Headset Orbit 1.5E ZS 1 1/8 / 1.5 semi + 1 1/8 crown race

- ★ **331172** Cube Kathmandu Hybrid ONE 625 black 'n' grey 2020
- ★ **331171** Cube Kathmandu Hybrid ONE 500 black 'n' grey 2020

**FRAME#** Aluminum Superlite, Gravity Casting Technology, Efficient Comfort Geometry, Tapered Headtube, Full Integrated Battery, Integrated Carrier 2.0  
**SIZE#** Men: 50, 54, 58, 62; Trapeze: 46, 50, 54; Easy Entry: 46, 50, 54, 58  
**FORK#** Suntour XCM ATB Coil, 100mm

**DRIVE UNIT#** Bosch Drive Unit Performance CX Generation 4 (75Nm) Cruise (250Watt)  
**BATTERY#** Bosch PowerTube 625  
**DISPLAY#** Bosch Purion  
**CHARGER#** Bosch 2A

**HEADSET#** SA Orbit 1.5B ZS-R, Top Zero-Stack 1 1/8" (OD 44mm), Bottom Zero-Stack 1 1/2" (OD 56mm)  
**STEM#** CUBE Performance Stem Pro, 31.8mm  
**HANDLEBAR#** CUBE Rise Trail Bar, 700mm  
**GRIPS#** CUBE Performance Grip  
**REAR DERAILLEUR#** Shimano RD-M2000-SGS, 9-Speed  
**SHIFTERS#** Shimano SL-M2010-9R, Rapidfire-Plus  
**BRAKE SYSTEM#** Shimano BR-MT200, Hydr. Disc Brake (180/180)  
**CRANKSET#** CID E-Crank, 38T, 175mm  
**CASSETTE#** Shimano CS-HG201, 11-36T  
**CHAIN#** MC X9  
**RIMS#** CUBE EX23, 36H, Disc, Tubeless Ready  
**FRONT HUB#** Shimano HB-TX505, QR, Centerlock  
**REAR HUB#** Shimano FH-TX505, QR, Centerlock  
**TYRES#** Schwalbe Big Ben, Performance, 55-622  
**PEDALS#** CUBE PP MTB  
**SADDLE#** Natural Fit Sequence Comfort  
**SEAT POST#** CUBE Performance Post, 30.9mm  
**SEATCLAMP#** CUBE Varioclose, 34.9mm  
**FRONT LIGHT#** CUBE Shiny 50 Lux, 6-12V, DC  
**REAR LIGHT#** CUBE IC 2.0 Rear LED, 6-12V, DC  
**KICKSTAND#** CUBEstand Cmp  
**MUDGUARDS#** CID 65  
**BELL#** Mini Bell  
**CARRIER#** CUBE Integrated Carrier 2.0, CUBE Adapter Compatible, SnapIt Compatible and Rail

**WEIGHT#** 5,5 kg

# KATHMANDU HYBRID 45

Trapeze | iridium'n'red



# KATHMANDU HYBRID 45

iridium'n'red



13015

CUBE BOTTLE CAGE HPP

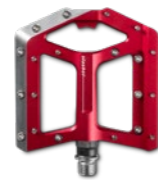

14113

CUBE PEDALE SLASHER



11967

CUBE GLOVES WS X NF

Speed pedelecs re-write the rules of urban cycling – and the Kathmandu Hybrid 45 re-writes the rules for speed pedelecs. Conceived around our versatile, comfortable and practical Kathmandu Hybrid frame, fourth-generation Bosch power with a powerful 625Wh battery and easy-to-use Intuvia controller puts the world at your feet. Full of neat touches and equipped with the most reliable components we could find, you'll wonder how you ever managed without it. The elegant frame features our sleek, strong and sturdy Integrated Carrier 2.0 – the perfect way to carry your belongings and essentials with you, whether you're just nipping across town or exploring further afield at the weekend. The high-capacity battery is entirely contained within the bike's down tube, thanks to our new Modular Battery System – but you can charge it without removing it. A Shimano 12-speed SLX and XT transmission transfers your pedalling and the Bosch system's power seamlessly and smoothly to the rear wheel, while comfortable and grippy Marathon E-Plus tyres in a 55mm width work with the Suntour Mobie45 air suspension fork to ensure you're comfortable and in full control. Powerful Magura hydraulic disc brakes with oversized rotors offer dependable stopping whatever the weather, full-length mudguards help keep you drier, built-in lights – with a brake light, too – ensure you can always see and be seen... and we even included a convenient kickstand so that you don't need to rely on the nearest wall or lamppost. Fully equipped for any journey, the Kathmandu Hybrid 45 is the eco-friendly way to get around that you've been looking for.

★ **331402** Cube Kathmandu Hybrid 45 625 iridium'n'red 2020

**FRAME** Aluminum Superlite, Gravity Casting Technology, Efficient Comfort Geometry, Tapered Headtube, Full Integrated Battery, Integrated Carrier 2.0  
**SIZE** Men: 50, 54, 58, 62; Trapeze: 46, 50, 54  
**FORK** Suntour Mobie 45 LO-R Air, 100mm

**DRIVE UNIT** Bosch Drive Unit Performance CX Generation 4 (75Nm) Speed (350Watt)  
**BATTERY** Bosch PowerTube 625  
**DISPLAY** Bosch Intuvia  
**CHARGER** Bosch 4A

**HEADSET** SA 1.5E ZS, Tapered, Top Zero-Stack 1 1/8" (OD 44mm), Bottom Zero-Stack 1 1/2" (OD 56mm)  
**STEM** CUBE Performance Stem Pro, 31.8mm  
**HANDLEBAR** CUBE Rise Trail Bar Pro, 720mm  
**GRIPS** Natural Fit Comfort  
**REAR DERAILLEUR** Shimano XT RD-M8100-SGS, ShadowPlus, 12-Speed  
**SHIFTERS** Shimano XT SL-M8100  
**BRAKE SYSTEM** Magura MT5e, Hydr. Disc Brake (203/203)  
**CRANKSET** CID E-Crank, 38T, 175mm  
**CASSETTE** Shimano SLX CS-M7100, 10-51T  
**CHAIN** Shimano SLX CN-M7100  
**RIMS** CUBE EX23, 36H, Disc, Tubeless Ready  
**FRONT HUB** Shimano HB-MT400-B, 15mm, Boost, Centerlock  
**REAR HUB** Shimano FH-MT500, QR, Centerlock  
**TYRES** Schwalbe Marathon E-Plus, 55-622  
**PEDALS** CUBE PP Trekking  
**SADDLE** Natural Fit Sequence+ Comfort  
**SEAT POST** CUBE Performance Post, 30.9mm  
**SEATCLAMP** CUBE Varioclose, 34.9mm  
**FRONT LIGHT** Busch&Müller Lumotec IQ-X  
**REAR LIGHT** Busch&Müller E-Brake  
**KICKSTAND** CUBEstand Pro, Adjustable  
**MUDGUARDS** CID 65

**SPARE PARTS#**  
**10148** CUBE Hanger #148 short version  
**10338** CUBE Headset Orbit 1.5E ZS 1 1/8 / 1.5 semi + 1 1/8 crown race

**WEIGHT** #5,9 kg



---

## FOR us #Travellers

---

One of the hallmarks of the CUBE Touring Hybrid range is its versatility. But it was just as important to us that this versatility should be available to the widest possible range of riders – which is why we set our engineers the task of designing not one, but three frame designs. We knew they'd come up trumps, and they did. Whether you opt for the Trapeze, Men's or Easy Entry version of the Touring Hybrid, you can be assured of a frame that's passed our rigorous in-house safety testing. Each one positions the Bosch drive unit and battery optimally, using a combination of clever frame manufacturing technologies like complex hydroforming and gravity casting, so that weight is kept low and stiffness is kept high. The result, when combined with our proprietary Efficient Comfort Geometry, is a Bosch e-bike that handles just as good as it looks. Internal cable routing reduces clutter and maintenance and helps keep gears shifting cleanly. And the integrated luggage rack is such a neat idea, you'll wonder how you managed without it.





# TOURING HYBRID EXC

Trapeze | blue'n'orange



# TOURING HYBRID EXC

blue'n'orange



Easy Entry | blue'n'orange



Sometimes, picking the right tool for the job means taking the decision to leave compromises behind. The Touring Hybrid EXC does just that, putting the best-quality components at the fingertips of its rider for the ultimate in hassle-free Bosch e-bike reliability. Based around our sleek, durable and easy-to-ride Touring Hybrid frame – available in Men's, Trapeze and Easy Entry variants to suit any rider – our product managers have selected the kit that's proven itself over time. So, for example, there's an 11-speed Shimano XT and SLX transmission with wide-ranging 11-46 tooth cassette – putting the right gear for any hill just a click or two away. Shimano hydraulic disc brakes with an upgraded four-piston front calliper offer smooth, powerful stopping in any weather conditions, while 47mm Schwalbe tyres give you the comfort and control you need to stay safe. The easily adjustable, air-sprung Suntour suspension fork helps smooth out even rough road surfaces, while the suspension seat post ensures you'll stay comfortably seated on longer rides. Combined with our carefully crafted frame with integrated luggage carrier for safe, intuitive handling – and a selection of finishing components including full mudguards, integrated lighting system and a kickstand – it's all you need for miles of smiles, wherever your next journey takes you. Truly, a Bosch e-bike for all reasons.

- SPARE PARTS#**
- 10149** CUBE Hanger #149 long version
  - 10338** CUBE Headset Orbit 1.5E ZS 1 1/8 / 1.5 semi + 1 1/8 crown race

★ **331161** Cube Touring Hybrid EXC 500 blue'n'orange 2020

**FRAME#** Aluminium Superlite, Gravity Casting, Efficient Comfort Geometry, Integrated Carrier 2.0  
**SIZE#** Men: 50, 54, 58, 62; Trapeze: 46, 50, 54; Easy Entry: 46, 50, 54, 58  
**FORK#** Suntour NCX D LO Air, 63mm, Lockout

**DRIVE UNIT#** Bosch Drive Unit Performance Generation 3 (65Nm) Cruise (250Watt)  
**BATTERY#** Bosch PowerPack 500  
**DISPLAY#** Bosch Intuvia  
**CHARGER#** Bosch 2A

**HEADSET#** SA Orbit 1.5E ZS-R, Top Zero-Stack 1 1/8" (OD 44mm), Bottom Zero-Stack 1 1/2" (OD 56mm)  
**STEM#** CUBE Performance Stem Pro, 31.8mm; EE: Satori Up2 Plus, 31.8mm, Adjustable  
**HANDLEBAR#** CUBE Rise Trail Bar, 700mm  
**GRIPS#** Natural Fit Comfort  
**REAR DERAILLEUR#** Shimano XT RD-M8000-DGS, ShadowPlus, 11-Speed  
**SHIFTERS#** Shimano SLX SL-M7000  
**BRAKE SYSTEM#** Shimano BR-MT420/MT400, Hydr. Disc Brake (180/160)  
**CRANKSET#** SA CK-602, 38T, 175mm  
**CASSETTE#** Shimano SLX CS-M7000, 11-46T  
**CHAIN#** MC X11  
**RIMS#** CUBE EX23, 36H, Disc, Tubeless Ready  
**FRONT HUB#** Shimano Deore HB-M6000, QR, Centerlock  
**REAR HUB#** Shimano Deore FH-M6000, QR, Centerlock  
**TYRES#** Schwalbe Marathon GT Tour, Performance, Dualguard, 47-622  
**PEDALS#** CUBE PP MTB  
**SADDLE#** Natural Fit Sequence+ Comfort  
**SEAT POST#** CUBE Suspension Seatpost, 27.2mm  
**SEATCLAMP#** CUBE Varioclose, 31.8mm  
**FRONT LIGHT#** Herrmans H-Black MR8, 6-12V, DC  
**REAR LIGHT#** Herrmans H-Trace  
**KICKSTAND#** CUBEstand Pro, Adjustable  
**MUDGUARDS#** CID 53  
**BELL#** Mini Bell  
**CARRIER#** CUBE Integrated Carrier 2.0, CUBE Adapter Compatible, SnapIt Compatible and Rail

**WEIGHT#** 3,5 kg

# TOURING HYBRID EXC

Trapeze | iridium'n'green



Easy Entry | iridium'n'green



# TOURING HYBRID EXC

iridium'n'green



Sometimes, picking the right tool for the job means taking the decision to leave compromises behind. The Touring Hybrid EXC does just that, putting the best-quality components at the fingertips of its rider for the ultimate in hassle-free Bosch e-bike reliability. Based around our sleek, durable and easy-to-ride Touring Hybrid frame – available in Men's, Trapeze and Easy Entry variants to suit any rider – our product managers have selected the kit that's proven itself over time. So, for example, there's an 11-speed Shimano XT and SLX transmission with wide-ranging 11-46 tooth cassette – putting the right gear for any hill just a click or two away. Shimano hydraulic disc brakes with an upgraded four-piston front calliper offer smooth, powerful stopping in any weather conditions, while 47mm Schwalbe tyres give you the comfort and control you need to stay safe. The easily adjustable, air-sprung Suntour suspension fork helps smooth out even rough road surfaces, while the suspension seat post ensures you'll stay comfortably seated on longer rides. Combined with our carefully crafted frame with integrated luggage carrier for safe, intuitive handling – and a selection of finishing components including full mudguards, integrated lighting system and a kickstand – it's all you need for miles of smiles, wherever your next journey takes you. Truly, a Bosch e-bike for all reasons.

- SPARE PARTS#**
- 10149** CUBE Hanger #149 long version
  - 10338** CUBE Headset Orbit 1.5E ZS 1 1/8 / 1.5 semi + 1 1/8 crown race

★ **331151** Cube Touring Hybrid EXC 500 iridium'n'green 2020

**FRAME#** Aluminium Superlite, Gravity Casting, Efficient Comfort Geometry, Integrated Carrier 2.0  
**SIZE#** Men: 50, 54, 58, 62; Trapeze: 46, 50, 54; Easy Entry: 46, 50, 54, 58  
**FORK#** Suntour NCX D LO Air, 63mm, Lockout

**DRIVE UNIT#** Bosch Drive Unit Performance Generation 3 (65Nm) Cruise (250Watt)  
**BATTERY#** Bosch PowerPack 500  
**DISPLAY#** Bosch Intuvia  
**CHARGER#** Bosch 2A

**HEADSET#** SA Orbit 1.5E ZS-R, Top Zero-Stack 1 1/8" (OD 44mm), Bottom Zero-Stack 1 1/2" (OD 56mm)  
**STEM#** CUBE Performance Stem Pro, 31.8mm; EE: Satori Up2 Plus, 31.8mm, Adjustable  
**HANDLEBAR#** CUBE Rise Trail Bar, 700mm  
**GRIPS#** Natural Fit Comfort  
**REAR DERAILLEUR#** Shimano XT RD-M8000-DGS, ShadowPlus, 11-Speed  
**SHIFTERS#** Shimano SLX SL-M7000  
**BRAKE SYSTEM#** Shimano BR-MT420/MT400, Hydr. Disc Brake (180/160)  
**CRANKSET#** SA CK-602, 38T, 175mm  
**CASSETTE#** Shimano SLX CS-M7000, 11-46T  
**CHAIN#** MC X11  
**RIMS#** CUBE EX23, 36H, Disc, Tubeless Ready  
**FRONT HUB#** Shimano Deore HB-M6000, QR, Centerlock  
**REAR HUB#** Shimano Deore FH-M6000, QR, Centerlock  
**TYRES#** Schwalbe Marathon GT Tour, Performance, Dualguard, 47-622  
**PEDALS#** CUBE PP MTB  
**SADDLE#** Natural Fit Sequence+ Comfort  
**SEAT POST#** CUBE Suspension Seatpost, 27.2mm  
**SEATCLAMP#** CUBE Varioclose, 31.8mm  
**FRONT LIGHT#** Herrmans H-Black MR8, 6-12V, DC  
**REAR LIGHT#** Herrmans H-Trace  
**KICKSTAND#** CUBEstand Pro, Adjustable  
**MUDGUARDS#** CID 53  
**BELL#** Mini Bell  
**CARRIER#** CUBE Integrated Carrier 2.0, CUBE Adapter Compatible, SnapIt Compatible and Rail

**WEIGHT#** 3,5 kg

# TOURING HYBRID PRO

Trapeze | grey'n' red



# TOURING HYBRID PRO

grey'n' red



Easy Entry | grey'n' red



Whether you're tackling a longer commute or fancy exploring further afield at the weekends, the Touring Hybrid Pro is the Bosch e-bike for the job. Bosch's Performance motor gives ample power to boost your own pedalling, backed up by a long-lasting 500Wh battery for excellent range. Quiet, unobtrusive and reliable, it works seamlessly with Bosch's clever software to deliver a ride that's so smooth, you'll soon forget that you're riding a pedal-assist bike. Whichever option you choose – Easy Entry, Trapeze or Men's – our engineers have worked hard to integrate the Bosch system into a frame design that's as strong and safe as it is elegant and easy to live with. The low centre of gravity ensures safe handling, and the fact that every CUBE frame has to pass our stringent in-house testing is your guarantee of a long and trouble-free life. Throw in the integrated luggage rack, the mudguards and lights and a set of components picked specifically for their reliability, and you've got all you need for any riding adventure. From the comfortable Suntour suspension fork to the wide-ranging Shimano Deore 10-speed gears and powerful, all-weather hydraulic disc brakes, there's everything here that you need .... and nothing that you don't. We even included a suspension seat post for extra comfort on those longer rides at the weekend. Now, where will your next adventure take you?

- SPARE PARTS#**
- 10149** CUBE Hanger #149 long version
  - 10338** CUBE Headset Orbit 1.5E ZS 1 1/8 / 1.5 semi + 1 1/8 crown race

★ **331111** Cube Touring Hybrid Pro 500 grey'n' red 2020

**FRAME#** Aluminium Superlite, Gravity Casting, Efficient Comfort Geometry, Integrated Carrier 2.0  
**SIZE#** Men: 50, 54, 58, 62; Trapeze: 46, 50, 54; Easy Entry: 46, 50, 54, 58  
**FORK#** Suntour NEX-E25 HLO, 63mm, Lockout

**DRIVE UNIT#** Bosch Drive Unit Performance Generation 3 (65Nm) Cruise (250Watt)  
**BATTERY#** Bosch PowerPack 500  
**DISPLAY#** Bosch Intuvia  
**CHARGER#** Bosch 2A

**HEADSET#** SA Orbit 1.5B ZS-R, Top Zero-Stack 1 1/8" (OD 44mm), Bottom Zero-Stack 1 1/2" (OD 56mm)  
**STEM#** CUBE Performance Stem Pro, 31.8mm; EE: Satori Up2 Plus, 31.8mm, Adjustable  
**HANDLEBAR#** CUBE Rise Trail Bar, 700mm  
**GRIPS#** Natural Fit Comfort  
**REAR DERAILLEUR#** Shimano Deore RD-M6000-DGS, ShadowPlus, 10-Speed  
**SHIFTERS#** Shimano Deore SL-M6000, Rapidfire-Plus  
**BRAKE SYSTEM#** Shimano BR-MT200, Hydr. Disc Brake (180/160)  
**CRANKSET#** SA CK-602, 38T, 175mm  
**CASSETTE#** Shimano Deore CS-HG500, 11-42T  
**CHAIN#** MC X10  
**RIMS#** CUBE EX23, 36H, Disc, Tubeless Ready  
**FRONT HUB#** Shimano HB-TX505, QR, Centerlock  
**REAR HUB#** Shimano FH-TX505, QR, Centerlock  
**TYRES#** Schwalbe Range Cruiser, Active, K-Guard, 47-622  
**PEDALS#** CUBE PP MTB  
**SADDLE#** Natural Fit Sequence Comfort  
**SEAT POST#** CUBE Suspension Seatpost, 27.2mm  
**SEATCLAMP#** CUBE Varioclose, 31.8mm  
**FRONT LIGHT#** Herrmans H-Black MR-ECO, 6-12V, DC  
**REAR LIGHT#** Herrmans H-Trace  
**KICKSTAND#** CUBEstand Cmp  
**MUDGUARDS#** CID 53  
**BELL#** Mini Bell  
**CARRIER#** CUBE Integrated Carrier 2.0, CUBE Adapter Compatible, SnapIt Compatible and Rail

**WEIGHT#** 3,9 kg

# TOURING HYBRID PRO

Trapeze | iridium'n'black



# TOURING HYBRID PRO

iridium'n'black



Easy Entry | iridium'n'black



Whether you're tackling a longer commute or fancy exploring further afield at the weekends, the Touring Hybrid Pro is the Bosch e-bike for the job. Bosch's Performance motor gives ample power to boost your own pedalling, backed up by a long-lasting 500Wh battery for excellent range. Quiet, unobtrusive and reliable, it works seamlessly with Bosch's clever software to deliver a ride that's so smooth, you'll soon forget that you're riding a pedal-assist bike. Whichever option you choose – Easy Entry, Trapeze or Men's – our engineers have worked hard to integrate the Bosch system into a frame design that's as strong and safe as it is elegant and easy to live with. The low centre of gravity ensures safe handling, and the fact that every CUBE frame has to pass our stringent in-house testing is your guarantee of a long and trouble-free life. Throw in the integrated luggage rack, the mudguards and lights and a set of components picked specifically for their reliability, and you've got all you need for any riding adventure. From the comfortable Suntour suspension fork to the wide-ranging Shimano Deore 10-speed gears and powerful, all-weather hydraulic disc brakes, there's everything here that you need .... and nothing that you don't. We even included a suspension seat post for extra comfort on those longer rides at the weekend. Now, where will your next adventure take you?

- SPARE PARTS#**
- 10149** CUBE Hanger #149 long version
  - 10338** CUBE Headset Orbit 1.5E ZS 1 1/8 / 1.5 semi + 1 1/8 crown race

★ **331101** Cube Touring Hybrid Pro 500 iridium'n'black 2020

**FRAME#** Aluminium Superlite, Gravity Casting, Efficient Comfort Geometry, Integrated Carrier 2.0  
**SIZE#** Men: 50, 54, 58, 62; Trapeze: 46, 50, 54; Easy Entry: 46, 50, 54, 58  
**FORK#** Suntour NEX-E25 HLO, 63mm, Lockout

**DRIVE UNIT#** Bosch Drive Unit Performance Generation 3 (65Nm) Cruise (250Watt)  
**BATTERY#** Bosch PowerPack 500  
**DISPLAY#** Bosch Intuvia  
**CHARGER#** Bosch 2A

**HEADSET#** SA Orbit 1.5B ZS-R, Top Zero-Stack 1 1/8" (OD 44mm), Bottom Zero-Stack 1 1/2" (OD 56mm)  
**STEM#** CUBE Performance Stem Pro, 31.8mm; EE: Satori Up2 Plus, 31.8mm, Adjustable  
**HANDLEBAR#** CUBE Rise Trail Bar, 700mm  
**GRIPS#** Natural Fit Comfort  
**REAR DERAILLEUR#** Shimano Deore RD-M6000-DGS, ShadowPlus, 10-Speed  
**SHIFTERS#** Shimano Deore SL-M6000, Rapidfire-Plus  
**BRAKE SYSTEM#** Shimano BR-MT200, Hydr. Disc Brake (180/160)  
**CRANKSET#** SA CK-602, 38T, 175mm  
**CASSETTE#** Shimano Deore CS-HG500, 11-42T  
**CHAIN#** MC X10  
**RIMS#** CUBE EX23, 36H, Disc, Tubeless Ready  
**FRONT HUB#** Shimano HB-TX505, QR, Centerlock  
**REAR HUB#** Shimano FH-TX505, QR, Centerlock  
**TYRES#** Schwalbe Range Cruiser, Active, K-Guard, 47-622  
**PEDALS#** CUBE PP MTB  
**SADDLE#** Natural Fit Sequence Comfort  
**SEAT POST#** CUBE Suspension Seatpost, 27.2mm  
**SEATCLAMP#** CUBE Varioclose, 31.8mm  
**FRONT LIGHT#** Herrmans H-Black MR-ECO, 6-12V, DC  
**REAR LIGHT#** Herrmans H-Trace  
**KICKSTAND#** CUBEstand Cmp  
**MUDGUARDS#** CID 53  
**BELL#** Mini Bell  
**CARRIER#** CUBE Integrated Carrier 2.0, CUBE Adapter Compatible, SnapIt Compatible and Rail

**WEIGHT#** 3,9 kg

# TOURING HYBRID ONE

Trapeze | green'n'white



# TOURING HYBRID ONE

green'n'white



Easy Entry | green'n'white



Whatever you do, wherever you go, the Touring Hybrid ONE will get you there in comfort and style. Our affordable, adaptable hybrid tourer has everything you need to make riding your Bosch e-bike a pleasure. Whether you opt for the Easy Entry, Trapeze or Men's version, our engineers have carefully crafted the frame to ensure seamless integration of the Bosch drive unit and battery. They're in the optimum position for safe handling and sleek good looks so that, combined with our Efficient Comfort Geometry, you can rest assured that the Touring Hybrid ONE will be safe and easy to handle – and, like every CUBE bike, it's passed all our in-house lab tests. Smooth-shifting, easy-to-use Shimano 9-speed gears work flawlessly with Bosch's system to make every journey a breeze – and the internal cable routing ensures that the shifts will stay smooth and reliable for a long time to come, with minimal maintenance. Powerful hydraulic disc brakes offer predictable stopping in all weathers and the mudguards, lighting system, kickstand and luggage carrier ensure you're fully equipped for any eventuality. Just jump on and ride...

- SPARE PARTS#**
- 10148** CUBE Hanger #148 short version
  - 10338** CUBE Headset Orbit 1.5E ZS 1 1/8 / 1.5 semi + 1 1/8 crown race

- ★ **331061** Cube Touring Hybrid ONE 500 green'n'white 2020
- 331060** Cube Touring Hybrid ONE 400 green'n'white 2020

**FRAME#** Aluminium Superlite, Gravity Casting, Efficient Comfort Geometry, Semi-Integrated Carrier  
**SIZE#** Men: 50, 54, 58, 62; Trapeze: 46, 50, 54; Easy Entry: 46, 50, 54, 58  
**FORK#** Suntour NEX-E25, 63mm

**DRIVE UNIT#** Bosch Drive Unit Active Plus Generation 3 (50Nm) Cruise (250Watt)  
**BATTERY#** Bosch PowerPack 500  
**DISPLAY#** Bosch Purion  
**CHARGER#** Bosch 2A

**HEADSET#** SA Orbit 1.5B ZS-1-R, Top Zero-Stack 1 1/8" [OD 44mm], Bottom Zero-Stack 1 1/2" [OD 56mm]  
**STEM#** CUBE Performance Stem Pro, 31.8mm  
**HANDLEBAR#** CUBE Rise Trail Bar, 700mm  
**GRIPS#** CUBE Performance Grip  
**REAR DERAILLEUR#** Shimano RD-M2000-SGS, 9-Speed  
**SHIFTERS#** Shimano SL-M2010-9R, Rapidfire-Plus  
**BRAKE SYSTEM#** Shimano BR-MT200, Hydr. Disc Brake (180/160)  
**CRANKSET#** SA CK-602, 38T, 175mm  
**CASSETTE#** Shimano CS-HG201, 11-36T  
**CHAIN#** MC X9  
**RIMS#** CUBE EX23, 36H, Disc, Tubeless Ready  
**FRONT HUB#** Shimano HB-TX505, QR, Centerlock  
**REAR HUB#** Shimano FH-TX505, QR, Centerlock  
**TYRES#** Schwalbe Range Cruiser, Active, K-Guard, 47-622  
**PEDALS#** CUBE PP MTB  
**SADDLE#** Natural Fit Sequence Comfort  
**SEAT POST#** CUBE Performance Post, 27.2mm  
**SEATCLAMP#** CUBE Varioclose, 31.8mm  
**FRONT LIGHT#** AXA Compactline 20, 6-12V, DC  
**REAR LIGHT#** relock LS 611 Duo Flat  
**KICKSTAND#** CUBEstand Cmp  
**MUDGUARDS#** CID 53  
**BELL#** Mini Bell  
**CARRIER#** CID Semi-Integrated Carrier, ACID RILink Adapter Compatible

**WEIGHT#** 3,2 kg

# TOURING HYBRID ONE

Trapeze | black'n'blue



# TOURING HYBRID ONE

black'n'blue



Easy Entry | black'n'blue



Whatever you do, wherever you go, the Touring Hybrid ONE will get you there in comfort and style. Our affordable, adaptable hybrid tourer has everything you need to make riding your Bosch e-bike a pleasure. Whether you opt for the Easy Entry, Trapeze or Men's version, our engineers have carefully crafted the frame to ensure seamless integration of the Bosch drive unit and battery. They're in the optimum position for safe handling and sleek good looks so that, combined with our Efficient Comfort Geometry, you can rest assured that the Touring Hybrid ONE will be safe and easy to handle – and, like every CUBE bike, it's passed all our in-house lab tests. Smooth-shifting, easy-to-use Shimano 9-speed gears work flawlessly with Bosch's system to make every journey a breeze – and the internal cable routing ensures that the shifts will stay smooth and reliable for a long time to come, with minimal maintenance. Powerful hydraulic disc brakes offer predictable stopping in all weathers and the mudguards, lighting system, kickstand and luggage carrier ensure you're fully equipped for any eventuality. Just jump on and ride...

- SPARE PARTS#**
- 10148** CUBE Hanger #148 short version
  - 10338** CUBE Headset Orbit 1.5E ZS 1 1/8 / 1.5 semi + 1 1/8 crown race

- ★ **331051** Cube Touring Hybrid ONE 500 black'n'blue 2020
- 331050** Cube Touring Hybrid ONE 400 black'n'blue 2020

**FRAME#** Aluminium Superlite, Gravity Casting, Efficient Comfort Geometry, Semi-Integrated Carrier  
**SIZE#** Men: 50, 54, 58, 62; Trapeze: 46, 50, 54; Easy Entry: 46, 50, 54, 58  
**FORK#** Suntour NEX-E25, 63mm

**DRIVE UNIT#** Bosch Drive Unit Active Plus Generation 3 (50Nm) Cruise (250Watt)  
**BATTERY#** Bosch PowerPack 500  
**DISPLAY#** Bosch Purion  
**CHARGER#** Bosch 2A

**HEADSET#** SA Orbit 1.5B ZS-1-R, Top Zero-Stack 1 1/8" [OD 44mm], Bottom Zero-Stack 1 1/2" [OD 56mm]  
**STEM#** CUBE Performance Stem Pro, 31.8mm  
**HANDLEBAR#** CUBE Rise Trail Bar, 700mm  
**GRIPS#** CUBE Performance Grip  
**REAR DERAILLEUR#** Shimano RD-M2000-SGS, 9-Speed  
**SHIFTERS#** Shimano SL-M2010-9R, Rapidfire-Plus  
**BRAKE SYSTEM#** Shimano BR-MT200, Hydr. Disc Brake (180/160)  
**CRANKSET#** SA CK-602, 38T, 175mm  
**CASSETTE#** Shimano CS-HG201, 11-36T  
**CHAIN#** MC X9  
**RIMS#** CUBE EX23, 36H, Disc, Tubeless Ready  
**FRONT HUB#** Shimano HB-TX505, QR, Centerlock  
**REAR HUB#** Shimano FH-TX505, QR, Centerlock  
**TYRES#** Schwalbe Range Cruiser, Active, K-Guard, 47-622  
**PEDALS#** CUBE PP MTB  
**SADDLE#** Natural Fit Sequence Comfort  
**SEAT POST#** CUBE Performance Post, 27.2mm  
**SEATCLAMP#** CUBE Varioclose, 31.8mm  
**FRONT LIGHT#** AXA Compactline 20, 6-12V, DC  
**REAR LIGHT#** relock LS 611 Duo Flat  
**KICKSTAND#** CUBEstand Cmp  
**MUDGUARDS#** CID 53  
**BELL#** Mini Bell  
**CARRIER#** CID Semi-Integrated Carrier, ACID RILink Adapter Compatible

**WEIGHT#** 3,2 kg

# U R B A N



236 **COMPACT**

242 **TOWN**

256 **TOWN SPORT**

264 **ELLA**

**URBAN**  
URBAN

**COMFORT**  
COMFORT

**TOUR**  
TOUR

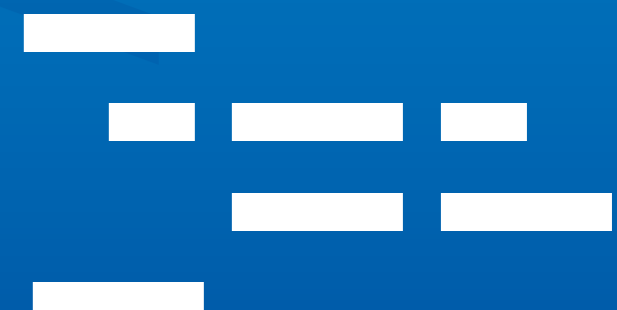

**COMPACT**

The all-new Compact Hybrid is the Bosch-powered e-bike for everyone. Small, nimble and easily adaptable to any rider or journey, it's the clever urban mobility solution that'll slot so easily into your life, you'll wonder how you ever managed without it. Ride the future, save the planet: sorted.

**TOWN**

Tame the urban jungle on your own terms. The Town Hybrid has got it all covered: smooth Bosch power, neatly integrated. Super safe and stable handling, standard. Comfortable design, sorted. Essential accessories, included. Low maintenance components, no worries. Just jump on and arrive in style. Your way.

**TOWN SPORT**

The Town Sport puts the fun back into your riding, whether you use it around town or to explore further afield. With its comfortable frame, confidence-inspiring handling and the smooth, seamless power of Bosch's neatly integrated drive system, you'll love its sporty feel and amazing versatility. Where will it take you next?

**ELLA**

Designed elegance and high tech, in perfect harmony. The Ella's classic retro styling, colour-coordinated detailing and almost invisible Bosch power unit integration make it easy to like. What will make you fall in love is the way it rides. In a word: sublime.

# 20" COMPACT SPORT HYBRID

---

## FOR us #Commuters

---

Building the Compact Hybrid – one-size-fits-all urban hybrid for the 21st century – demanded a completely new approach. To design a compact, durable, easy-to-ride and versatile bike that would slot easily into a busy lifestyle, our engineers began by building a compact frame around 20in wheels. The simple, cross-braced down tube is elegant, stiff and strong. It also makes the Compact Hybrid easy to step in and out of, as well as providing a convenient carry handle. The long head tube ensures accurate steering, whilst the smooth and powerful Bosch drive unit lives neatly in a custom housing at the bottom of the frame, and we located the battery behind the seat tube, close to the bike's centre of gravity and out of the way of both luggage and the rider. Quick saddle and handlebar adjustments allow one bike to fit a wide range of riders, too. It might not usher in a revolution in urban transport, but we like to think it's part of the solution.





## 20" COMPACT SPORT HYBRID

white'n'black



## 20" COMPACT SPORT HYBRID

blue'n'red

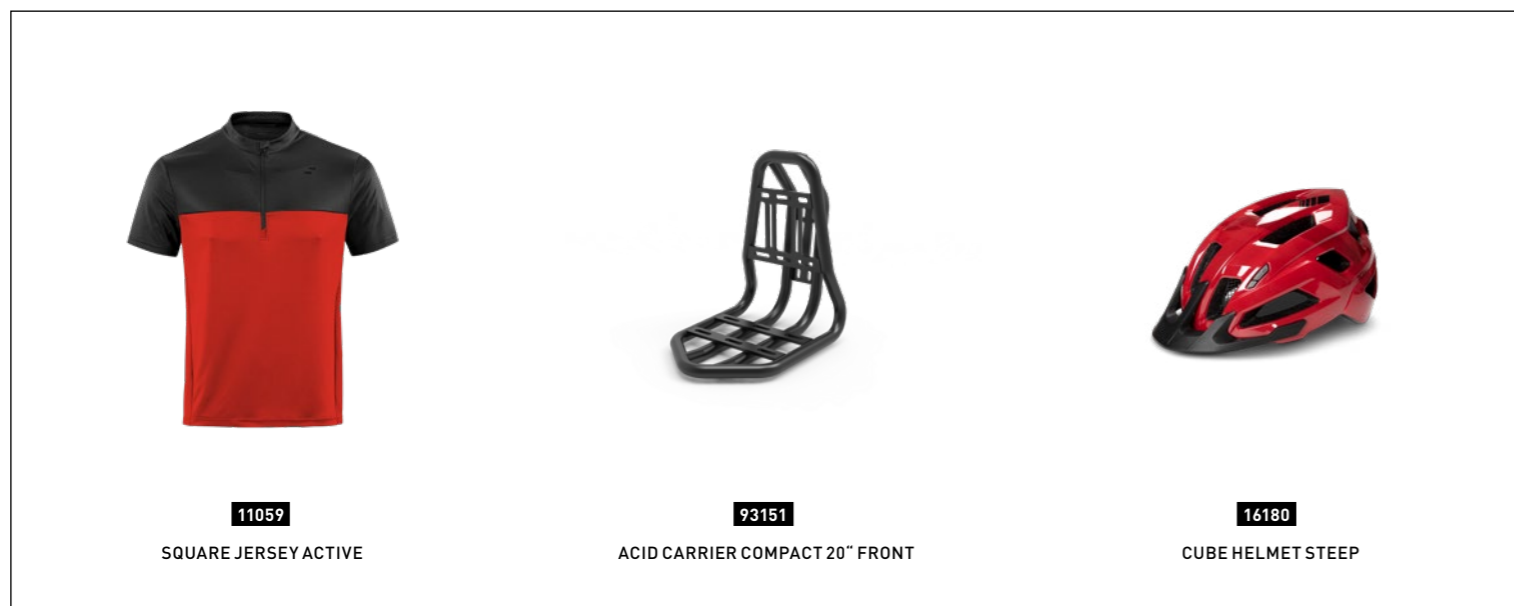

11059

SQUARE JERSEY ACTIVE



93151

ACID CARRIER COMPACT 20" FRONT



16180

CUBE HELMET STEEP

Towns and cities are in trouble, plagued by slow-moving traffic and poor air quality. But getting around can be fun, safe and doesn't need to involve sitting in a tin box. Say hello to our brand-new Compact Sport Hybrid – a Bosch e-bike that re-writes the rules of urban mobility. Powered by Bosch's quiet, powerful and sporty Performance drive unit and 500Wh battery, we fitted Shimano's reliable 10-speed derailleur gear system for its ease of use and wide range – enough to tackle any hill with ease. You'll be amazed at the simple, intuitive way the Bosch system takes your pedalling power and adds to it, taking the stress and sweat out of riding and turning it into a simple everyday pleasure that's both healthy for you, and good for the environment. The rugged, easy step-through frame fits riders of all sizes thanks to the easily adjustable saddle and handlebar positions, while compact 20in wheels mean it's zippy and manoeuvrable out on the streets, and compact and easy to store at home. We fitted mudguards to help keep you drier when the roads are wet, and it's fully compatible with front and rear luggage carriers so that you can easily carry all your day-to-day stuff around with you. There's even the possibility to mount a lock, so you've got peace of mind when you have to leave it outside a shop or office for a short while. And, of course, powerful disc brakes work safely and predictably in all weathers, ensuring you're always in full control. The Compact Sport Hybrid is so much fun, so versatile and so easy to live with, you'll wonder why no-one came up with this idea before...

- ★ **389160** Cube Compact Sport Hybrid blue'n'red 2020
- ★ **389150** Cube Compact Sport Hybrid white'n'black 2020

**FRAME** Aluminium Superlite, Comfort Ride Geometry, Semi-Integrated Carrier, Double Butted, Front-Carrier Ready, Slider Dropout  
**SIZE** One Size  
**FORK** Aluminium

**DRIVE UNIT** Bosch Drive Unit Performance Generation 3 (65Nm) Cruise (250Watt)  
**BATTERY** Bosch PowerPack 500  
**DISPLAY** Bosch Purion  
**CHARGER** Bosch 2A

**HEADSET** SA No.10, Semi-Integrated  
**STEM** bySchulz Speedlifter Twist Pro SDS T14  
**HANDLEBAR** CUBE Comfort Trail Bar, 15° Setback, 720mm  
**GRIPS** Natural Fit Comfort  
**REAR DERAILLEUR** Shimano Deore RD-M6000-DGS, 10-Speed  
**SHIFTERS** Shimano Deore SL-M6000  
**BRAKE SYSTEM** Shimano BR-MT200, Hydr. Disc Brake (180/160)  
**CRANKSET** SA Metropolis Comfort, 44T, 165mm  
**CASSETTE** Shimano CS-HG50, 11-36T  
**CHAIN** MC X10  
**RIMS** CUBE EX30, 32H, Disc, Tubeless Ready  
**FRONT HUB** Shimano HB-TX505, QR, Centerlock  
**REAR HUB** Shimano FH-TX505, QR, Centerlock  
**TYRES** Schwalbe Super Moto-X, Double Defense, 64-406  
**SADDLE** Natural Fit Nuance Lite  
**SEAT POST** Newmen Evolution, 27.2mm  
**SEATCLAMP** CUBE Varioclose, 31.8mm  
**FRONT LIGHT** Herrmans H-Black MR4, 6-12V, DC  
**REAR LIGHT** CID Pro E-Rear Mudguard  
**KICKSTAND** CUBE CentreStand  
**MUDGUARDS** ACID 75  
**BELL** Mini Bell  
**CARRIER** CID 20" Semi-Integrated Carrier, ACID RiLink Adapter Compatible

**SPARE PARTS#**  
**8003** CUBE Dropout do-adapter-right\_20\_HYCOMPACT(18-03550)  
**8004** CUBE Dropout do-adapter-left\_20\_HYCOMPACT(18-03552)  
**8005** CUBE do-nut-\_20\_HY-COMPACT(18-03558)  
**10324** CUBE Headset Orbit Z

**WEIGHT** #3,1 kg

## 20" COMPACT HYBRID

iridium 'n' black



## 20" COMPACT HYBRID

green 'n' green



At CUBE we've known for a long time that bikes are part of the solution to the urban mobility problem. But the brand-new Compact Hybrid is something different – a purpose-built, small-wheeled Bosch e-bike that's designed to slot easily into anyone's life, reducing the need to travel by car and, well... just making things simpler. Because simpler is good, right? Yeah, we thought so too. Built around a one-size-fits-all frame and compact 20in wheels, it doesn't take up much room but adapts easily to any rider thanks to easily adjustable handlebar and saddle positions – and there's the possibility to mount a lock to help prevent someone else riding off on your pride and joy. The step-through frame design makes it easy to get on and off, and Bosch's Active Plus drive unit and 500Wh battery gives a smooth, quiet and completely hassle-free boost to your pedalling. A comfortable seat and handlebar mean you'll love riding it, while low-maintenance internal hub gears ensure that hills and traffic are a breeze, and we included full-length mudguards to help keep you drier and more comfortable, even when the weather isn't cooperating. Speaking of which, powerful all-weather disc brakes mean you've no worries about stopping, even when it's wet. You can fit a rack front or rear – or even both – for carrying all your stuff, and wide 2.4in tyres offer lots of reassuring grip and comfort, even on poorly maintained city streets. Quiet, compact – as its name suggests – and so easy to live with you'll wonder how you managed without it, the Compact Hybrid is the reliable companion that everyone needs.

- ★ **389110** Cube Compact Hybrid green 'n' green 2020
- ★ **389100** Cube Compact Hybrid iridium 'n' black 2020

**FRAME** Aluminium Superlite, Comfort Ride Geometry, Semi-Integrated Carrier, Double Butted, Front-Carrier Ready, Slider Dropout  
**SIZE** One Size  
**FORK** Aluminium

**DRIVE UNIT** Bosch Drive Unit Active Plus Generation 3 (50Nm) Cruise (250Watt)  
**BATTERY** Bosch PowerPack 500  
**DISPLAY** Bosch Purion  
**CHARGER** Bosch 2A

**HEADSET** SA No.10, Semi-Integrated  
**STEM** BySchulz Speedlifter Twist Pro SDS T14  
**HANDLEBAR** CUBE Comfort Trail Bar, 15° Setback, 720mm  
**GRIPS** RFR Comfort  
**SHIFTERS** Shimano Nexus SL-C7000-5  
**BRAKE SYSTEM** Shimano BR-MT200, Hydr. Disc Brake (180/160)  
**CRANKSET** SA Metropolis Comfort, 44T, 165mm  
**SPROCKET** Shimano Nexus, 24T  
**CHAIN** MC Z610  
**RIMS** CUBE EX30, 32H, Disc, Tubeless Ready  
**FRONT HUB** Shimano HB-TX505, QR, Centerlock  
**REAR HUB** Shimano Nexus SG-C7000-5D, 5-Speed, Nut  
**TYRES** Schwalbe Super Moto-X, Double Defense, 64-406  
**SADDLE** Natural Fit Nuance Lite  
**SEAT POST** Newmen Evolution, 27.2mm  
**SEATCLAMP** CUBE Varioclose, 31.8mm  
**FRONT LIGHT** Herrmans H-Black MR4, 6-12V, DC  
**REAR LIGHT** CID Pro E-Rear Mudguard  
**KICKSTAND** CUBE CentreStand  
**MUDGUARDS** CID 75  
**BELL** Mini Bell  
**CARRIER** CID 20" Semi-Integrated Carrier, ACID RILink Adapter Compatible

**WEIGHT** 3.7 kg

- SPARE PARTS#**
- 8003** CUBE Dropout do-adapter-right\_20\_HYCOMPACT(18-03550)
  - 8004** CUBE Dropout do-adapter-left\_20\_HYCOMPACT(18-03552)
  - 8005** CUBE do-nut-\_20\_HY-COMPACT(18-03558)
  - 10324** CUBE Headset Orbit Z



13334

ACID FOLDING LOCK RIGID 90



93125

ACID CARRIER BASKET 20 RILINK RATTAN



93151

ACID CARRIER COMPACT 20" FRONT



---

## FOR us #BikingEnthusiasts

---

The Town Hybrid's frame is – despite the elegant simplicity of its looks – a tour de force of engineering excellence. The Easy Entry frame has been specifically designed to withstand the considerable power of the Bosch drive unit, providing effortless handling thanks to our Comfort Ride Geometry and the reassurance that it's passed all our stringent in-house safety tests. Siting the battery unit behind the stiff, strong, triple-chamber seat tube keeps it out of the way and puts it in the best position for easy handling, while the Bosch drive unit sits inside its own gravity cast housing. Practical touches like internally routed cables complement the frame's clean looks, as well as improving gear-shifting performance in the long term. And the integrated luggage carrier is exceptionally strong and stiff. It's the kind of attention to detail you'd expect from CUBE.



# TOWN HYBRID SL

iridium'n'gold



Your search for the very best in comfortable, safe and easy-to-live-with Bosch urban e-bikes starts and ends here, with the Town Hybrid SL. We've taken all the elements that make our Town Hybrids so popular – easy handling, unmatched versatility, excellent safety and low maintenance – and combined it with the quiet performance and easier shifting of Shimano's Nexus 8-speed hub with electronic Di2 shifting. The Shimano and Bosch systems work in perfect harmony, delivering seamless gear shifts every single time and helping to reduce component wear and maintenance requirements in the process. The Easy Entry frame does exactly what it promises, providing straightforward access for every rider in a frame that's still light, stiff and stable. The Bosch drive unit's location in a custom gravity cast housing harnesses its power safely and effortlessly, while the battery is positioned in the best place for easy, intuitive handling in combination with our Comfort Ride Geometry. Hydraulic rim brakes provide safe stopping in any weather, the RockShox Paragon Gold air-sprung fork smooths your passage over potholed city streets and rough country roads alike, and the integrated luggage carrier offers a safe, strong and stable platform on which to carry... well, whatever you want to carry. We even included full mudguards, an integrated lighting set, a kickstand and a suspension seat post. It's all set to go... now, where will it take you?

★ **332301** Cube Town Hybrid SL 500 iridium'n'gold 2020

**FRAME** Aluminium Superlite, Comfort Ride Geometry, Premium Comfort And Safety, Integrated Carrier 2.0, Double Butted  
**SIZE** Easy Entry: 42, 46, 50, 54, 58  
**FORK** RockShox Paragon Gold Air, 50mm, Lockout

**DRIVE UNIT** Bosch Drive Unit Performance Generation 3 (60Nm) Cruise (250Watt)  
**BATTERY** Bosch PowerPack 500  
**DISPLAY** Bosch Kiox  
**CHARGER** Bosch 4A

**HEADSET** SA No.10, Semi-Integrated  
**STEM** Satori Up2 Plus, 31.8mm, Adjustable  
**HANDLEBAR** CUBE Comfort Shape Bar  
**GRIPS** Natural Fit Comfort  
**SHIFTERS** Shimano SW-E6010-R, Di2  
**BRAKE SYSTEM** Magura HS11, Hydr. Caliper Brake  
**CRANKSET** SA Metropolis Comfort, 40T, 165mm  
**SPROCKET** Shimano Nexus, 20T  
**CHAIN** MC Z610, EcoProTeQ  
**CHAIN GUARD** Herrmans Halo-38  
**RIMS** CUBE ZX27, 36H, V-Brake  
**FRONT HUB** Shimano Deore HB-T610, QR  
**REAR HUB** Shimano Nexus SG-C6061-8V Premium, Di2, 8-Speed, Nut  
**TYRES** Schwalbe Marathon GT Tour, Performance, Dualguard, 47-622  
**PEDALS** CUBE PP MTB  
**SADDLE** Natural Fit Shen Ponso  
**SEAT POST** CUBE Suspension Seatpost, 27.2mm  
**SEATCLAMP** CUBE Varioclose, 31.8mm  
**FRONT LIGHT** Herrmans H-Black MR8, 6-12V, DC  
**REAR LIGHT** Herrmans H-Trace  
**KICKSTAND** CUBEstand Pro, Adjustable  
**MUDGUARDS** CID 53  
**BELL** Mini Bell  
**CARRIER** CUBE Integrated Carrier 2.0, CUBE Adapter Compatible, SnapIt Compatible and Rail



93123

ACID CARRIER BASKET 25 RILINK RATTAN



93270

ACID PEDALS FLAT C1-IB HYBRID



11565

NATURAL FIT SADDLE SHEN PONSO

**SPARE PARTS**  
**10324** CUBE Headset Orbit Z

**WEIGHT** 5,9 kg



# TOWN HYBRID EXC

black edition



# TOWN HYBRID EXC

red'n'black



With the Town Hybrid EXC we set out to build a Bosch e-bike for comfortable everyday use: for work, for shopping, for fun. Designed around our elegant Easy Entry Town Hybrid frame, its clean lines hide a wealth of practical touches like enclosed cables, ideal weight distribution for safe handling and our Comfort Ride Geometry to put you in the best riding position for efficiency, safety and – you guessed it – comfort. The integrated luggage carrier is a CUBE work of engineering art, combining elegant looks with incredible functionality and unmatched stiffness and strength for easy, secure load carrying. Shimano's smooth-shifting 8-speed Nexus hub gear system works seamlessly with the Bosch Performance drive unit to make light work of any journey, whether across town or into the countryside. Hydraulic rim brakes deliver safe, powerful and assured stopping in any weather conditions, while the fully enclosed chain and full-length mudguards help keep splashes and spray at bay. The RockShox Paragon Gold air fork helps smooth out even the most potholed of city streets, and we included front and rear lights – running from the Bosch battery – and a kickstand so that all you need to do is step aboard and ride. Smooth, reliable, adaptable and incredibly easy to live with, this is the Bosch e-bike that'll slot seamlessly into your everyday life.

- ★ **332211** Cube Town Hybrid EXC 500 red'n'black 2020
- ★ **332201** Cube Town Hybrid EXC 500 black edition 2020

**FRAME** Aluminium Superlite, Comfort Ride Geometry, Premium Comfort And Safety, Integrated Carrier 2.0, Double Butted  
**SIZE** Easy Entry: 42, 46, 50, 54, 58  
**FORK** RockShox Paragon Gold Air, 50mm, Lockout

**DRIVE UNIT** Bosch Drive Unit Performance Generation 3 (60Nm) Cruise (250Watt)  
**BATTERY** Bosch PowerPack 500  
**DISPLAY** Bosch Intuvia  
**CHARGER** Bosch 4A

**HEADSET** SA No.10, Semi-Integrated  
**STEM** Satori Up2 Plus, 31.8mm, Adjustable  
**HANDLEBAR** CUBE Comfort Shape Bar  
**GRIPS** RFR Comfort  
**SHIFTERS** Shimano Nexus SL-C6000-8, Revoshift  
**BRAKE SYSTEM** Magura HS11, Hydr. Caliper Brake  
**CRANKSET** SA Metropolis Comfort, 40T, 165mm  
**SPROCKET** Shimano Nexus, 20T  
**CHAIN** MC Z610, EcoProTeQ  
**CHAIN GUARD** CUBE Closed Chain Protection  
**RIMS** CUBE ZX27, 36H, V-Brake  
**FRONT HUB** Shimano Deore HB-T610, QR  
**REAR HUB** Shimano Nexus SG-C6001-8V, 8-Speed, Nut  
**TYRES** Schwalbe Marathon GT Tour, Performance, Dualguard, 47-622  
**PEDALS** CUBE PP MTB  
**SADDLE** Natural Fit Shen+  
**SEAT POST** CUBE Suspension Seatpost, 27.2mm  
**SEAT CLAMP** CUBE Varioclose, 31.8mm  
**FRONT LIGHT** Herrmans H-Black MR8, 6-12V, DC  
**REAR LIGHT** Herrmans H-Trace  
**KICKSTAND** CUBE Stand Cmp  
**MUDGUARDS** CID 53  
**BELL** Mini Bell  
**CARRIER** CUBE Integrated Carrier 2.0, CUBE Adapter Compatible, SnapIt Compatible and Rail

**WEIGHT** 6,1 kg

**SPARE PARTS**  
**10324** CUBE Headset Orbit Z

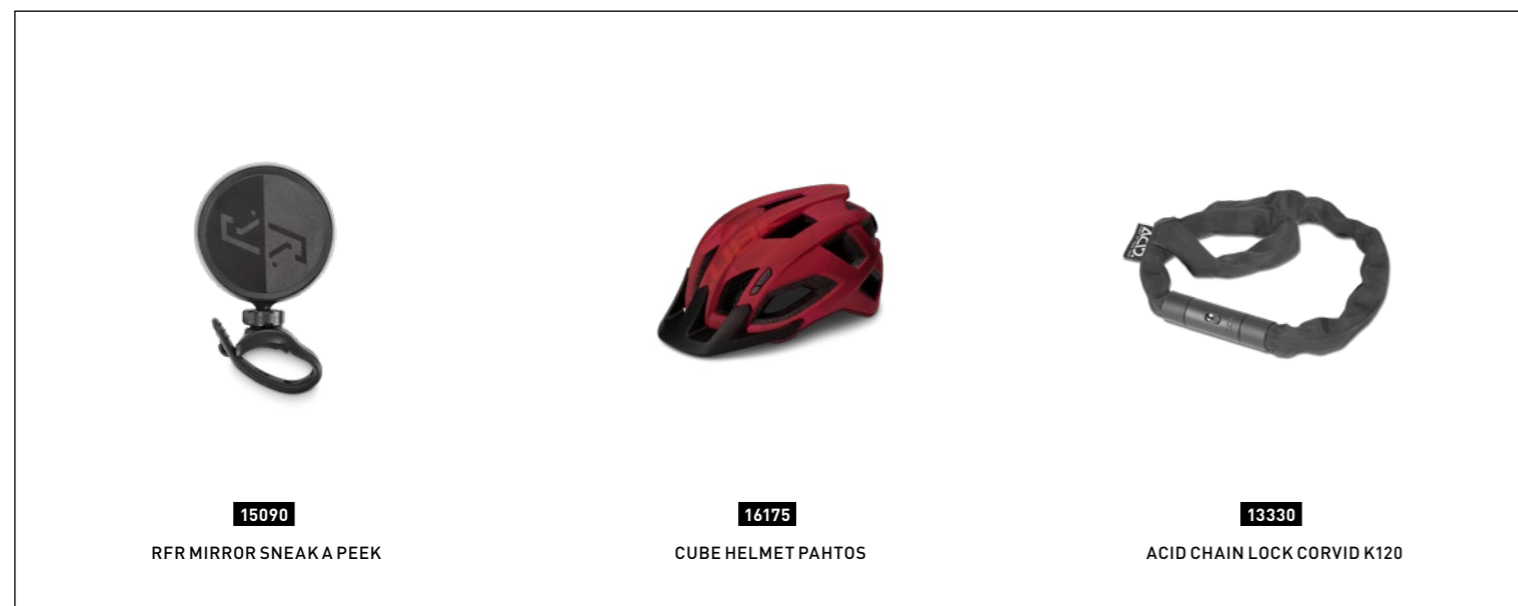

**15090**  
RFR MIRROR SNEAK A PEEK

**16175**  
CUBE HELMET PAHTOS

**13330**  
ACID CHAIN LOCK CORVID K120

# TOWN HYBRID EXC RT

black edition



# TOWN HYBRID EXC RT

red'n'black



There's a lot to be said for keeping things simple. That's why, when we developed the Town Hybrid EXC RT Bosch e-bike, we sweated the details. So, for example, the beautifully integrated luggage carrier doesn't just look good, it also provides an unbelievably strong, stiff and stable platform for you to carry whatever you need with you, whether across town or on a longer excursion into the countryside. Internal cable routing reduces clutter and ensures that the Shimano 8-speed hub gears keep shifting smoothly with absolutely minimal maintenance. Careful positioning of the battery and powerful drive unit, combined with our Comfort Ride Geometry, creates a balanced ride feel that you'll instantly take to. And, of course, the entire frame has been subjected to our in-house torture testing lab's attention, so you can be assured that it exceeds all current safety legislation. Components like the RockShox Paragon Gold air suspension fork – which effortlessly smooths out the lumps and bumps of urban streets – have been chosen with reliability and ease of use in mind. We fully enclosed the chain and fitted full-length mudguards, so you arrive at your destination looking as good as when you stepped out of your front door. An integrated lighting system allows you to see and be seen, and the easy-to-use back pedal brake works in conjunction with the powerful, all-weather hydraulic rim brakes to ensure you're always in full control. That's a whole lot of detail, but the result is an urban pedal-assist bike that's so simple to live with, you'll wish you'd discovered it earlier.

- ★ **332261** Cube Town Hybrid EXC RT 500 red'n'black 2020
- ★ **332251** Cube Town Hybrid EXC RT 500 black edition 2020

**FRAME** Aluminium Superlite, Comfort Ride Geometry, Premium Comfort And Safety, Integrated Carrier 2.0, Double Butted  
**SIZE** Easy Entry: 42, 46, 50, 54, 58  
**FORK** RockShox Paragon Gold Air, 50mm, Lockout

**DRIVE UNIT** Bosch Drive Unit Performance Generation 3 (60Nm) Cruise (250Watt)  
**BATTERY** Bosch PowerPack 500  
**DISPLAY** Bosch Intuvia  
**CHARGER** Bosch 4A

**HEADSET** SA No.10, Semi-Integrated  
**STEM** Satori Up2 Plus, 31.8mm, Adjustable  
**HANDLEBAR** CUBE Comfort Shape Bar  
**GRIPS** RFR Comfort  
**SHIFTERS** Shimano Nexus SL-C6000-8, Revoshift  
**BRAKE SYSTEM** Magura HS11, Hydr. Caliper Brake  
**CRANKSET** SA Metropolis Comfort, 40T, 165mm  
**SPROCKET** Shimano Nexus, 20T  
**CHAIN** MC Z610, EcoProTeQ  
**CHAIN GUARD** CUBE Closed Chain Protection  
**RIMS** CUBE ZX27, 36H, V-Brake  
**FRONT HUB** Shimano Deore HB-T610, QR  
**REAR HUB** Shimano Nexus SG-C6001-8C, 8-Speed, Coaster Brake, Nut  
**TYRES** Schwalbe Marathon GT Tour, Performance, Dualguard, 47-622  
**PEDALS** CUBE PP MTB  
**SADDLE** CUBE Natural Fit Shen+  
**SEAT POST** CUBE Suspension Seatpost, 27.2mm  
**SEAT CLAMP** CUBE Varioclose, 31.8mm  
**FRONT LIGHT** Herrmans H-Black MR8, 6-12V, DC  
**REAR LIGHT** Herrmans H-Trace  
**KICKSTAND** CUBE Stand Cmp  
**MUDGUARDS** CID 53  
**BELL** Mini Bell  
**CARRIER** CUBE Integrated Carrier 2.0, CUBE Adapter Compatible, SnapIt Compatible and Rail

**WEIGHT** 6,1 kg

**SPARE PARTS**  
**10324** CUBE Headset Orbit Z

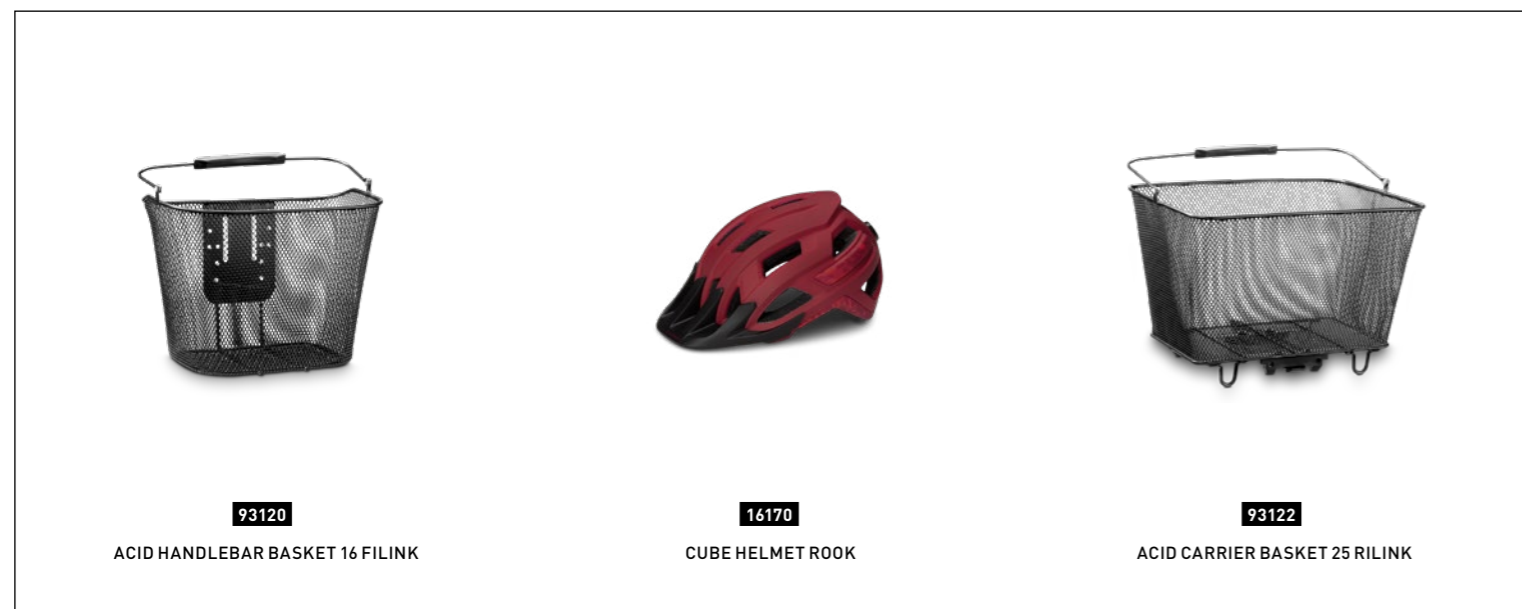

**93120**  
ACID HANDLEBAR BASKET 16 FILINK

**16170**  
CUBE HELMET ROOK

**93122**  
ACID CARRIER BASKET 25 RILINK

# TOWN HYBRID PRO

black'n'green



# TOWN HYBRID PRO

blue'n'orange



Sometimes it's the little touches that make all the difference. The CUBE Town Hybrid Pro features our strong, stiff and extremely elegant integrated luggage carrier. That might not seem such a big deal, but its clean design and exceptionally stable load-carrying ability mean that this is a Bosch e-bike that is as comfortable carrying your shopping or possessions across town as it is just riding door to door. Laden or unladen, its smooth Shimano 8-speed hub gears work seamlessly with the powerful Bosch drive unit to make light work of any journey. Strong hydraulic Magura rim brakes provide safe, assured stopping in any weather, while the fully enclosed chain guide and full-length mudguards help ensure you arrive at your destination clean and fresh. The frame's clean design hides neat, practical touches like internal cable routing and a setup that keeps battery and motor weight as low as possible for safe, nimble handling around town – and, of course, our own lab test team has confirmed that it's more than strong enough to pass even the toughest of safety standards. We included a kickstand for easy parking, a lighting system so you can see and be seen, and a suspension fork to help smooth out potholed streets. It's all you need for stress-free, versatile urban travel.

- ★ **332111** Cube Town Hybrid Pro 500 blue'n'orange 2020
- 332110** Cube Town Hybrid Pro 400 blue'n'orange 2020
- 332101** Cube Town Hybrid Pro 500 black'n'green 2020
- 332100** Cube Town Hybrid Pro 400 black'n'green 2020

**FRAME** Aluminium Superlite, Comfort Ride Geometry, Premium Comfort And Safety, Integrated Carrier 2.0, Double Butted  
**SIZE** Easy Entry: 42, 46, 50, 54, 58  
**FORK** Suntour NEX-E25, 50mm

**DRIVE UNIT** Bosch Drive Unit Active Plus Generation 3 (50Nm) Cruise (250Watt)  
**BATTERY** Bosch PowerPack 500  
**DISPLAY** Bosch Intuvia  
**CHARGER** Bosch 2A

**HEADSET** SA No.10, Semi-Integrated  
**STEM** Satori Up2 Plus, 31.8mm, Adjustable  
**HANDLEBAR** CUBE Comfort Shape Bar  
**GRIPS** RFR Comfort  
**SHIFTERS** Shimano Nexus SL-C6000-8, Revoshift  
**BRAKE SYSTEM** Magura HS11, Hydr. Caliper Brake  
**CRANKSET** SA Metropolis Comfort, 40T, 165mm  
**SPROCKET** Shimano Nexus, 20T  
**CHAIN** MC Z610, EcoProTeQ  
**CHAIN GUARD** CUBE Closed Chain Protection  
**RIMS** CUBE ZX27, 36H, V-Brake  
**FRONT HUB** Shimano HB-TX500, QR  
**REAR HUB** Shimano Nexus SG-C6001-8V, 8-Speed, Nut  
**TYRES** Schwalbe Marathon GT Tour, Performance, Dualguard, 47-622  
**PEDALS** CUBE PP MTB  
**SADDLE** Natural Fit Shen+  
**SEAT POST** CUBE Suspension Seatpost, 27.2mm  
**SEATCLAMP** CUBE Varioclose, 31.8mm  
**FRONT LIGHT** AXA Compactline 20, 6-12V, DC  
**REAR LIGHT** Herrmans H-Trace  
**KICKSTAND** CUBEstand Cmp  
**MUDGUARDS** CID 53  
**BELL** Mini Bell  
**CARRIER** CUBE Integrated Carrier 2.0, CUBE Adapter Compatible, SnapIt Compatible and Rail

**SPARE PARTS**  
**10324** CUBE Headset Orbit Z

**WEIGHT** 6,4 kg

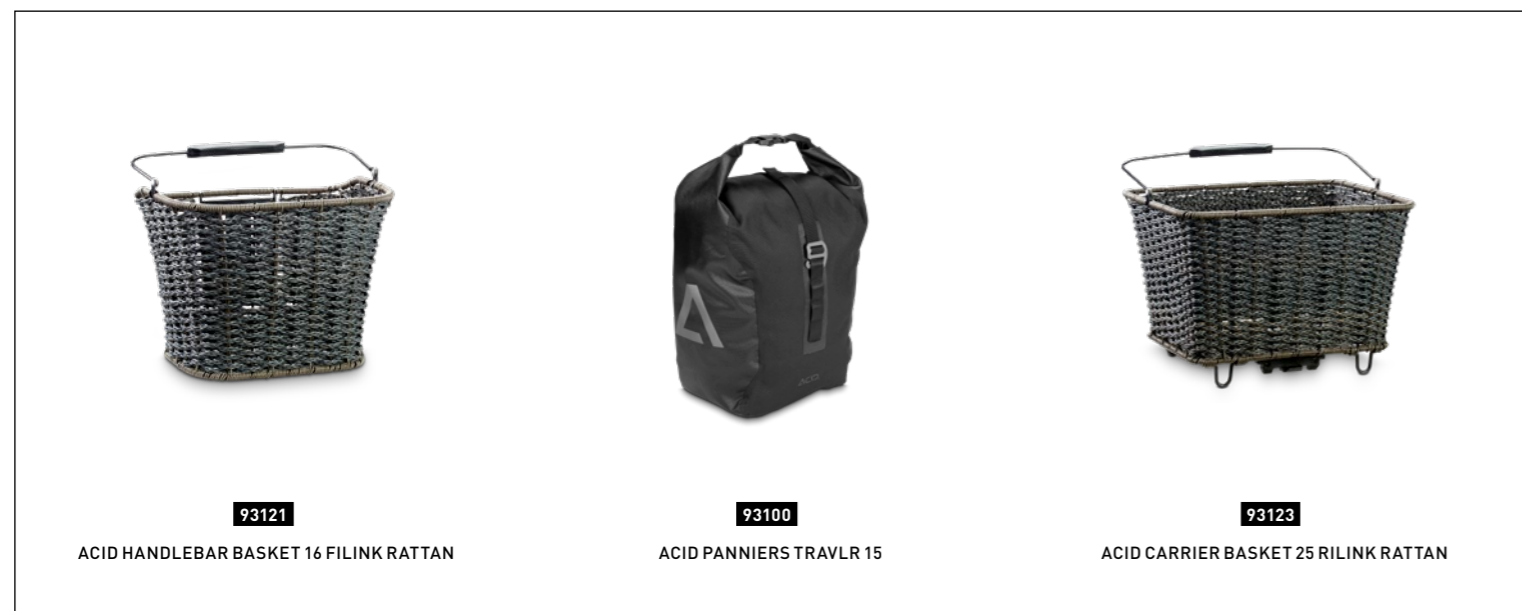

**93121**  
ACID HANDLEBAR BASKET 16 FILINK RATTAN

**93100**  
ACID PANNIERS TRAVLR 15

**93123**  
ACID CARRIER BASKET 25 RILINK RATTAN

# TOWN HYBRID PRO RT

black 'n' green



# TOWN HYBRID PRO RT

blue 'n' orange

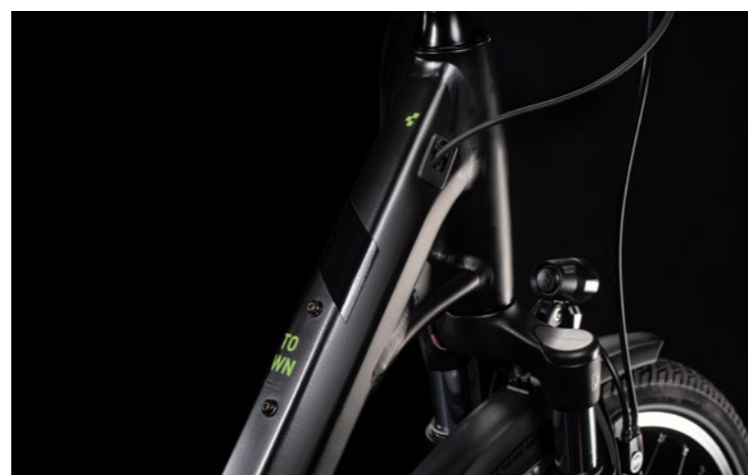

If you're looking for an affordable Bosch e-bike that combines easy urban mobility with elegant looks, low maintenance and all-round versatility, the CUBE Town Hybrid Pro RT should be at the top of your shortlist. The integrated luggage carrier, low-maintenance design, comfortable ride and emphasis on safety and practicality are all there to help this elegant pedal-assist bike slot easily into your life. Thoroughly tested by our in-house safety lab, you can be assured that it's as strong and durable as it is good to look at, too. We've included a suspension fork for greater comfort on rough roads, light and powerful Magura hydraulic rim brakes for added safety in all weathers, and easy-to-use Shimano 8-speed hub gears with a fully enclosed chain. The RT model also features an additional back pedal brake, to provide an extra option on top of the standard braking system and to put you in full control. Take a ride – you'll be surprised how much fun a practical urban e-bike can be.

- ★ **332161** Cube Town Hybrid Pro RT 500 blue 'n' orange 2020
- 332160** Cube Town Hybrid Pro RT 400 blue 'n' orange 2020
- 332151** Cube Town Hybrid Pro RT 500 black 'n' green 2020
- 332150** Cube Town Hybrid Pro RT 400 black 'n' green 2020

**FRAME** Aluminium Superlite, Comfort Ride Geometry, Premium Comfort And Safety, Integrated Carrier 2.0, Double Butted  
**SIZE** Easy Entry: 42, 46, 50, 54, 58  
**FORK** Suntour NEX-E25, 50mm

**DRIVE UNIT** Bosch Drive Unit Active Plus Generation 3 (50Nm) Cruise (250Watt)  
**BATTERY** Bosch PowerPack 500  
**DISPLAY** Bosch Intuvia  
**CHARGER** Bosch 2A

**HEADSET** SA No.10, Semi-Integrated  
**STEM** Satori Up2 Plus, 31.8mm, Adjustable  
**HANDLEBAR** CUBE Comfort Shape Bar  
**GRIPS** RFR Comfort  
**SHIFTERS** Shimano Nexus SL-C6000-8, Revoshift  
**BRAKE SYSTEM** Magura HS11, Hydr. Caliper Brake  
**CRANKSET** SA Metropolis Comfort, 40T, 165mm  
**SPROCKET** Shimano Nexus, 20T  
**CHAIN** MC Z610, EcoProTeQ  
**CHAIN GUARD** CUBE Closed Chain Protection  
**RIMS** CUBE ZX27, 36H, V-Brake  
**FRONT HUB** Shimano HB-TX500, QR  
**REAR HUB** Shimano Nexus SG-C6001-8C, 8-Speed, Coaster Brake, Nut  
**TYRES** Schwalbe Marathon GT Tour, Performance, Dualguard, 47-622  
**PEDALS** CUBE PP MTB  
**SADDLE** Natural Fit Shen+  
**SEAT POST** CUBE Suspension Seatpost, 27.2mm  
**SEATCLAMP** CUBE Varioclose, 31.8mm  
**FRONT LIGHT** AXA Compactline 20, 6-12V, DC  
**REAR LIGHT** Herrmans H-Trace  
**KICKSTAND** CUBEstand Cmp  
**MUDGUARDS** CID 53  
**BELL** Mini Bell  
**CARRIER** CUBE Integrated Carrier 2.0, CUBE Adapter Compatible, SnapIt Compatible and Rail

**SPARE PARTS#**  
**10324** CUBE Headset Orbit Z

**WEIGHT** #6,4 kg

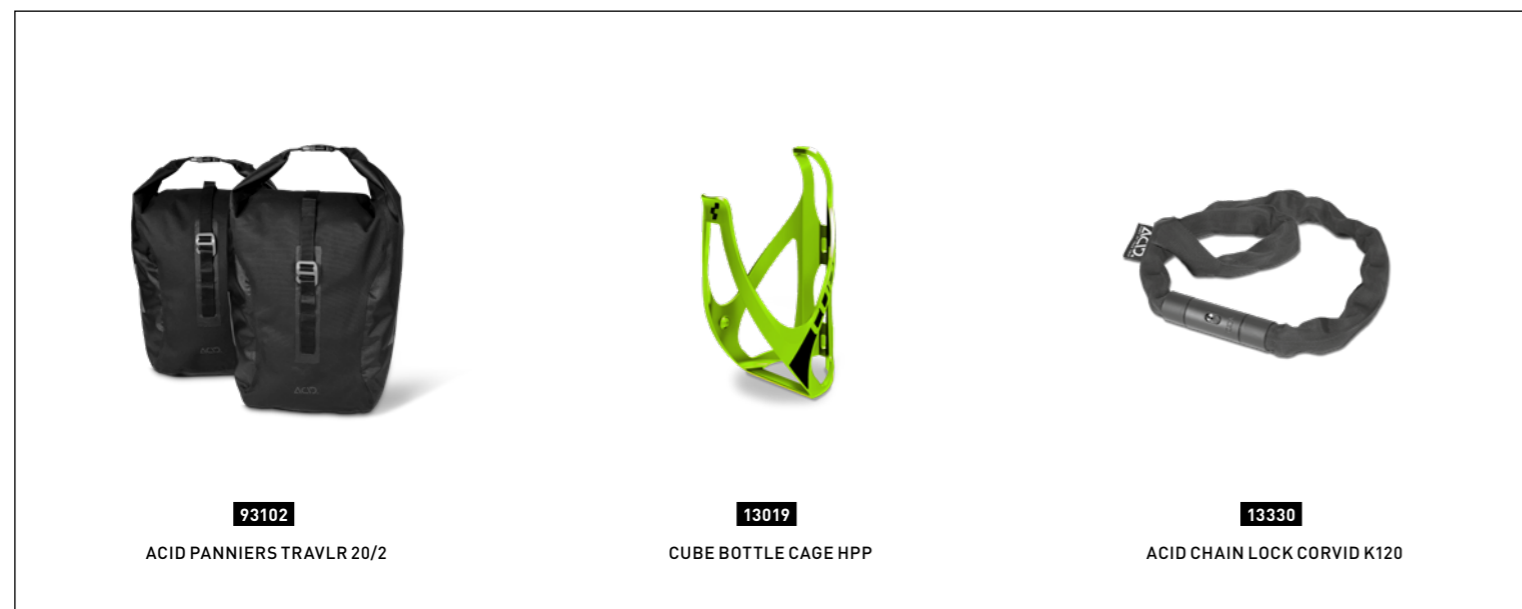

**93102**  
ACID PANNIERS TRAVLR 20/2

**13019**  
CUBE BOTTLE CAGE HPP

**13330**  
ACID CHAIN LOCK CORVID K120



# TOWN HYBRID ONE

iridium 'n' black

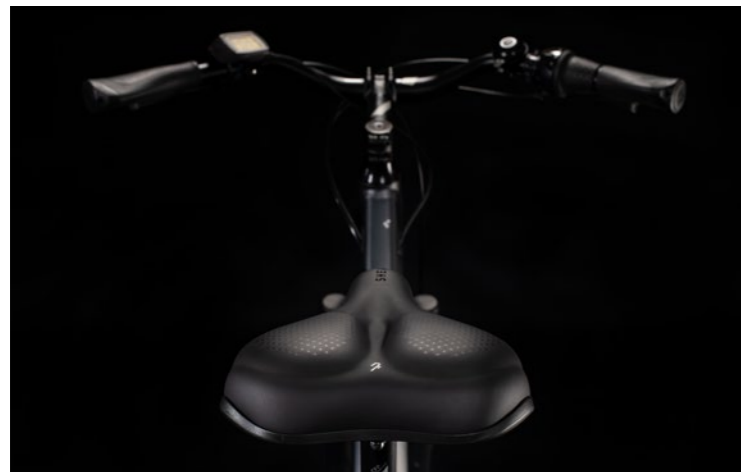

The Town Hybrid ONE Bosch e-bike has been designed with one clear goal in mind: to make your life easier. The elegant Easy Entry frame, easy-to-use Shimano 7-speed hub gears and smooth, powerful Bosch drive unit will deliver you from A to B almost effortlessly and in complete safety. The cunningly sited battery is tucked out of the way, while a completely enclosed chain and included mudguards help to keep your clothes clean and dry while you ride. The luggage carrier is perfect for bringing your essentials with you, there's a kickstand for park-anywhere convenience and an included lighting system ensure you can see and be seen at all times of day. We even included a comfortable suspension fork to help smooth out rough road surfaces. The frame bristles with neat design features like internally routed gear cables – which reduce clutter and maintenance requirements – and Comfort Ride Geometry, for stable and intuitive handling. And, of course, it's passed all our stringent in-house safety tests with flying colours, so you can be assured that it's more than strong and durable enough to withstand the rough and tumble of everyday life. Just jump on and ride – it'll fit so easily into your life, you'll wonder how you ever managed without it.

- ★ **332051** Cube Town Hybrid ONE 500 iridium 'n' black 2020
- ★ **332050** Cube Town Hybrid ONE 400 iridium 'n' black 2020

**FRAME** Aluminium Superlite, Comfort Ride Geometry, Comfort And Safety, Semi-Integrated Carrier, Double Butted  
**SIZE** Easy Entry: 42, 46, 50, 54, 58  
**FORK** Suntour NEX-E25, 50mm

**DRIVE UNIT** Bosch Drive Unit Active Generation 3 (40Nm) Cruise (250Watt)  
**BATTERY** Bosch PowerPack 500  
**DISPLAY** Bosch Purion  
**CHARGER** Bosch 2A

**HEADSET** SA No.10, Semi-Integrated  
**STEM** CUBE Performance Stem Pro, 31.8mm  
**HANDLEBAR** CUBE Comfort Shape Bar  
**GRIPS** RFR Comfort  
**SHIFTERS** Shimano Nexus SL-C3000-7, Revoshift  
**BRAKE SYSTEM** Magura HS11, Hydr. Caliper Brake  
**CRANKSET** SA Metropolis Comfort, 40T, 165mm  
**SPROCKET** Shimano Nexus, 20T  
**CHAIN** MC Z610, EcoProTeQ  
**CHAIN GUARD** CUBE Closed Chain Protection  
**RIMS** CUBE ZX27, 36H, V-Brake  
**FRONT HUB** Shimano HB-TX500, QR  
**REAR HUB** Shimano Nexus SG-C3000-7R, 7-Speed, Nut  
**TYRES** Schwalbe Road Cruiser, Active, 47-622  
**PEDALS** CUBE PP MTB  
**SADDLE** Natural Fit Shen  
**SEAT POST** CUBE Performance Post, 27.2mm  
**SEAT CLAMP** CUBE Varioclose, 31.8mm  
**FRONT LIGHT** AXA Compactline 20, 6-12V, DC  
**REAR LIGHT** relock LS 611 Duo Flat  
**KICKSTAND** CUBEstand CmpT  
**MUDGUARDS** CID 53  
**BELL** Mini Bell  
**CARRIER** CID Semi-Integrated Carrier, ACID RiLink Adapter Compatible

**WEIGHT** #4,4 kg

**SPARE PARTS#**  
**10324** CUBE Headset Orbit Z

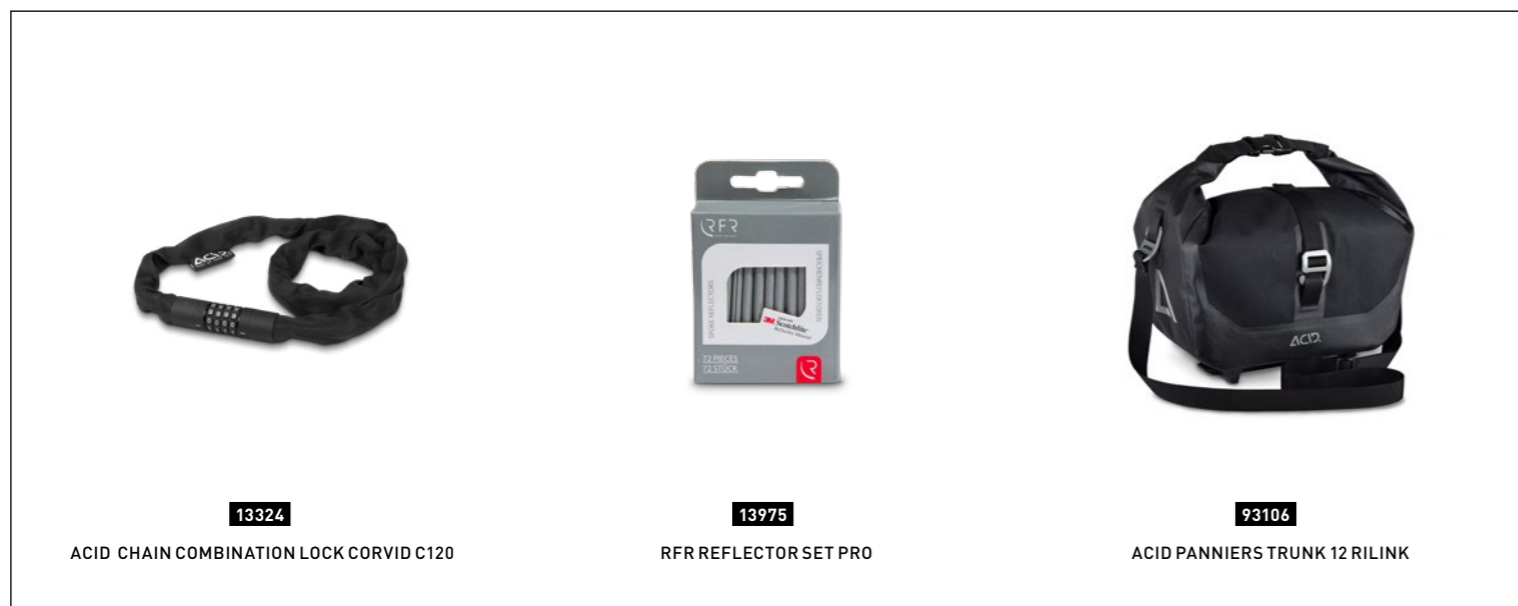

**13324**  
ACID CHAIN COMBINATION LOCK CORVID C120

**13975**  
RFR REFLECTOR SET PRO

**93106**  
ACID PANNIERS TRUNK 12 RILINK

---

## FOR us #BikingEnthusiasts

---

The Town Hybrid's frame is – despite the elegant simplicity of its looks – a tour de force of engineering excellence. The Easy Entry frame has been specifically designed to withstand the considerable power of the Bosch drive unit, providing effortless handling thanks to our Comfort Ride Geometry and the reassurance that it's passed all our stringent in-house safety tests. Siting the battery unit behind the stiff, strong, triple-chamber seat tube keeps it out of the way and puts it in the best position for easy handling, while the Bosch drive unit sits inside its own gravity cast housing. Practical touches like internally routed cables complement the frame's clean looks, as well as improving gear-shifting performance in the long term. And the integrated luggage carrier is exceptionally strong and stiff. It's the kind of attention to detail you'd expect from CUBE.



# TOWN SPORT HYBRID EXC

black'n'blue



# TOWN SPORT HYBRID EXC

grey'n'red



The Town Sport Hybrid EXC is one part workhorse, one part urban traffic-beater and one part weekend escape vehicle. A bike, in other words, for all reasons. The smooth shifting and exceptionally wide range of Shimano's superb SLX and XT 12-speed components, combined with the powerful Bosch Performance drive unit, makes light work out of even the steepest of hills. And, with a standard 500Wh battery tucked neatly behind the seat tube, you've no worries on running out of juice. The Easy Entry frame combines elegant good looks with comfort, poise and the reassurance of having passed our in-house safety tests with flying colours. We even routed gear cables internally, to complement the frame's neat lines and help reduce maintenance requirements. The integrated luggage carrier is a strong, stable and elegant way to transport your belongings in complete safety, whether you're nipping across town or planning a longer excursion. Powerful hydraulic disc brakes include an upgrade to a four-piston front calliper, for even safer stopping in all weather conditions. The suspension seat post, adjustable stem and smooth RockShox Paragon Gold suspension fork ensure that you'll be comfortable all day long. And a full complement of practical accessories – including mudguards, a chain guard, kickstand and lights that are neatly integrated to run off the Bosch battery – means you don't need to spend a penny more to get the bike that you want. The only thing missing... is you.

- ★ **332461** Cube Town Sport Hybrid EXC 500 grey'n'red 2020
- ★ **332451** Cube Town Sport Hybrid EXC 500 black'n'blue 2020

---

-  **FRAME** Aluminium Superlite, Comfort Ride Geometry, Premium Comfort And Safety, Integrated Carrier 2.0, Double Butted
- SIZE** Easy Entry: 42, 46, 50, 54, 58
- FORK** RockShox Paragon Gold Air, 50mm, Lockout

---

-  **DRIVE UNIT** Bosch Drive Unit Performance Generation 3 (65Nm) Cruise (250Watt)
- BATTERY** Bosch PowerPack 500
- DISPLAY** Bosch Kiox
- CHARGER** Bosch 4A

---

-  **HEADSET** SA No.10, Semi-Integrated
- STEM** Satori Up2 Plus, 31.8mm, Adjustable
- HANDLEBAR** CUBE Comfort Shape Bar
- GRIPS** Natural Fit Comfort
- REAR DERAILLEUR** Shimano XT RD-M8100-SGS, ShadowPlus, 12-Speed
- SHIFTERS** Shimano XT SL-M8100
- BRAKE SYSTEM** Shimano BR-MT520/MT500, Hydr. Disc Brake (180/160)
- CRANKSET** SA Metropolis Comfort, 38T, 165mm
- CASSETTE** Shimano SLX CS-M7100, 10-51T
- CHAIN** Shimano SLX CN-M7100
- CHAIN GUARD** Herrmans Halo-38
- RIMS** CUBE EX23, 36H, Disc
- FRONT HUB** Shimano HB-M4050, QR, Centerlock
- REAR HUB** Shimano FH-MT500, QR, Centerlock
- TYRES** Schwabe Marathon GT Tour, Performance, Dualguard, 47-622
- PEDALS** CUBE PP MTB
- SADDLE** Natural Fit Shen+
- SEAT POST** CUBE Suspension Seatpost, 27.2mm
- SEATCLAMP** CUBE Varioclose, 31.8mm
- FRONT LIGHT** Herrmans H-Black MR8, 6-12V, DC
- REAR LIGHT** Herrmans H-Trace
- KICKSTAND** CUBEstand Pro, Adjustable
- MUDGUARDS** A-CID 53
- BELL** Mini Bell
- CARRIER** CUBE Integrated Carrier 2.0, CUBE Adapter Compatible, SnapIt Compatible and Rail

---

-  **WEIGHT** #5,1 kg



**11443**

SQUARE WS JERSEY PERFORMANCE



**11421**

SQUARE WS BAGGY SHORTS ACTIVE



**11967**

CUBE GLOVES WS X NF

# TOWN SPORT HYBRID PRO

iridium n' red



# TOWN SPORT HYBRID PRO

green n' orange



You may not regard yourself as a pro, in cycling terms. But the Town Sport Hybrid Pro takes its job – as an easy-to-live-with, safe and dependable urban Bosch e-bike – very seriously. That's why we equipped it with Shimano's wide-ranging Deore 10-speed transmission. With easy shifts and an extraordinary broad gear range, there's not a hill too steep for you, the Town Sport Hybrid Pro and its powerful Bosch Performance drive unit. The Easy Entry frame's careful weight distribution, Comfort Ride Geometry and extensive in-lab safety testing means you can rest assured that it's safe and easy to handle – it's the least you'd expect from the CUBE design team. Strong and dependable Shimano hydraulic disc brakes provide safe, assured stopping in any weather conditions and the Suntour suspension fork – with lockout – takes the sting out of potholed streets. We even fitted an adjustable stem and suspension seat post, so you can be sure of the best possible fit and a comfortable ride. And the integrated luggage carrier – which complements the frame's sleek looks – provides an exceptionally strong, stable and secure platform for you to carry everything you need with you. That's why this bike is a Pro: we sweated the details, so that you don't have to.

- ★ **332411** Cube Town Sport Hybrid Pro 500 green n' orange 2020
- 332410** Cube Town Sport Hybrid Pro 400 green n' orange 2020
- 332401** Cube Town Sport Hybrid Pro 500 iridium n' red 2020
- 332400** Cube Town Sport Hybrid Pro 400 iridium n' red 2020

**FRAME** Aluminium Superlite, Comfort Ride Geometry, Premium Comfort And Safety, Integrated Carrier 2.0, Double Butted  
**SIZE** Easy Entry: 42, 46, 50, 54, 58  
**FORK** Suntour NEX-E25 HLO, 50mm, Lockout

**DRIVE UNIT** Bosch Drive Unit Performance Generation 3 (65Nm) Cruise (250Watt)  
**BATTERY** Bosch PowerPack 500  
**DISPLAY** Bosch Intuvia  
**CHARGER** Bosch 2A

**HEADSET** SA No.10, Semi-Integrated  
**STEM** satori Up2 Plus, 31.8mm, Adjustable  
**HANDLEBAR** CUBE Comfort Shape Bar  
**GRIPS** Natural Fit Comfort  
**REAR DERAILLEUR** Shimano Deore RD-M6000-DGS, ShadowPlus, 10-Speed  
**SHIFTERS** Shimano Deore SL-M6000, Rapidfire-Plus  
**BRAKE SYSTEM** Shimano BR-MT400, Hydr. Disc Brake (180/160)  
**CRANKSET** SA Metropolis Comfort, 38T, 165mm  
**CASSETTE** Shimano Deore CS-HG500, 11-42T  
**CHAIN** MC X10  
**CHAIN GUARD** Herrmans Halo-38  
**RIMS** CUBE EX23, 36H, Disc  
**FRONT HUB** Shimano Deore HB-M6000, QR, Centerlock  
**REAR HUB** Shimano Deore FH-M6000, QR, Centerlock  
**TYRES** Schwalbe Range Cruiser, Active, K-Guard, 47-622  
**PEDALS** CUBE PP MTB  
**SADDLE** Natural Fit Shen+  
**SEAT POST** CUBE Suspension Seatpost, 27.2mm  
**SEATCLAMP** CUBE Varioclose, 31.8mm  
**FRONT LIGHT** Herrmans H-Black MR4, 6-12V, DC  
**REAR LIGHT** Herrmans H-Trace  
**KICKSTAND** CUBEstand Pro, Adjustable  
**MUDGUARDS** CID 53  
**BELL** Mini Bell  
**CARRIER** CUBE Integrated Carrier 2.0, CUBE Adapter Compatible, SnapIt Compatible and Rail

**SPARE PARTS**  
**10149** CUBE Hanger #149 long version  
**10324** CUBE Headset Orbit Z

**WEIGHT** #5,2 kg

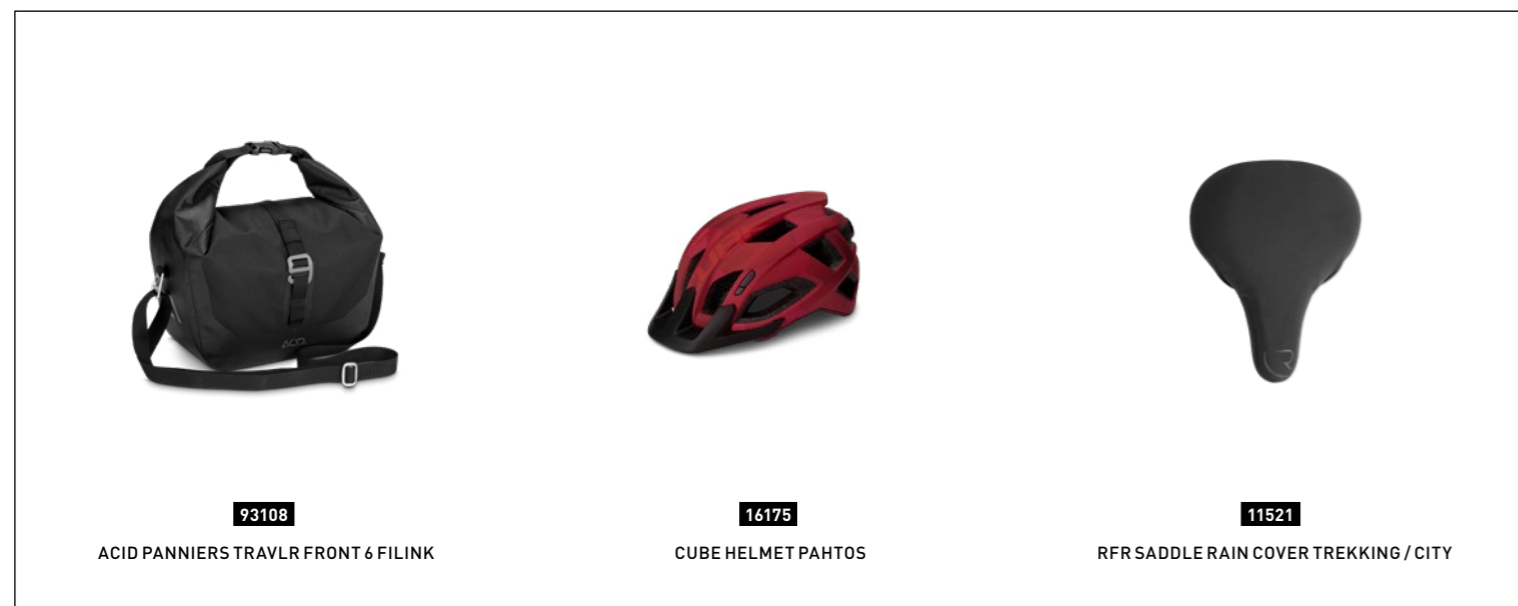

**93108**  
ACID PANNIERS TRAVLR FRONT 6 FILINK

**16175**  
CUBE HELMET PAHTOS

**11521**  
RFR SADDLE RAIN COVER TREKKING / CITY

# TOWN SPORT HYBRID ONE

black 'n' grey



What happens when you take the comfort, safety and practicality of our Town Hybrid range and combine it with the wide gear range and easy shifting of Shimano's 9-speed components? The Town Sport Hybrid ONE, that's what: a Bosch e-bike that makes getting around town a pleasure rather than a chore. With its Easy Entry frame and Comfort Ride Geometry, it's a bike that's as good to ride as it looks. Urban savvy comes courtesy of the included mudguards, kickstand and luggage carrier, so you're fully equipped for any journey. Sporty ride-anywhere ability is provided by the 9-speed Shimano transmission and powerful, all-weather hydraulic disc brakes, so you can explore beyond the urban jungle too. The Bosch motor gives you the added power you need to easily tackle any hill. And the suspension fork provides comfort on the roughest of road surfaces, while the integrated lighting system ensures you can see and be seen at all times of day. Wherever you need to be, the Town Sport Hybrid ONE will get you there quickly, safely and in comfort.

- ★ **332351** Cube Town Sport Hybrid ONE 500 black 'n' grey 2020
- 332350** Cube Town Sport Hybrid ONE 400 black 'n' grey 2020

**FRAME** Aluminium Superlite, Comfort Ride Geometry, Comfort And Safety, Semi-Integrated Carrier, Double Butted  
**SIZE** Easy Entry: 42, 46, 50, 54, 58  
**FORK** Suntour NEX-E25, 50mm

**DRIVE UNIT** Bosch Drive Unit Active Plus Generation 3 (50Nm) Cruise (250Watt)  
**BATTERY** Bosch PowerPack 500  
**DISPLAY** Bosch Purion  
**CHARGER** Bosch 2A

**HEADSET** SA No.10, Semi-Integrated  
**STEM** CUBE Performance Stem Pro, 31.8mm  
**HANDLEBAR** CUBE Comfort Shape Bar  
**GRIPS** Natural Fit Comfort  
**REAR DERAILLEUR** Shimano Deore RD-M592-SGS, 9-Speed  
**SHIFTERS** Shimano SL-M2010-9R, Rapidfire-Plus  
**BRAKE SYSTEM** Shimano BR-MT200, Hydr. Disc Brake (180/160)  
**CRANKSET** SA Metropolis Comfort, 38T, 165mm  
**CASSETTE** Shimano CS-HG201, 11-36T  
**CHAIN** MC X9  
**CHAIN GUARD** Herrmans Halo-38  
**RIMS** CUBE EX23, 36H, Disc, Tubeless Ready  
**FRONT HUB** Shimano HB-TX505, QR, Centerlock  
**REAR HUB** Shimano FH-TX505, QR, Centerlock  
**TYRES** Schwalbe Range Cruiser, Active, K-Guard, 47-622  
**PEDALS** CUBE PP MTB  
**SADDLE** Natural Fit Shen  
**SEAT POST** CUBE Performance Post, 27.2mm  
**SEATCLAMP** CUBE Varioclose, 31.8mm  
**FRONT LIGHT** AXA Compactline 20, 6-12V, DC  
**REAR LIGHT** relock LS 611 Duo Flat  
**KICKSTAND** CUBEstand Cmp  
**MUDGUARDS** ACID 53  
**BELL** Mini Bell  
**CARRIER** ACID Semi-Integrated Carrier, ACID RiLink Adapter Compatible

**SPARE PARTS**  
**10148** CUBE Hanger #148 short version  
**10324** CUBE Headset Orbit Z

**WEIGHT** #4,3 kg

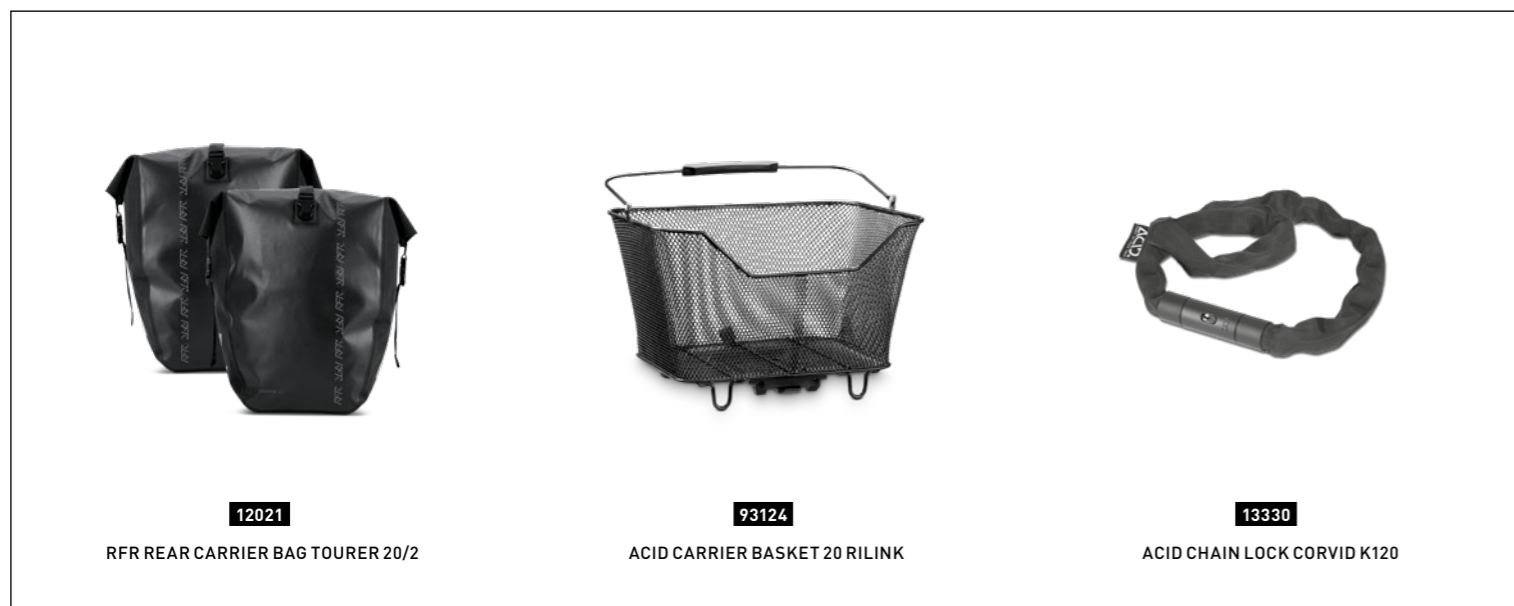

**12021**  
RFR REAR CARRIER BAG TOURER 20/2

**93124**  
ACID CARRIER BASKET 20 RILINK

**13330**  
ACID CHAIN LOCK CORVID K120

---

## FOR us #Individualists

---

As interested as they are in producing beautiful frames, our engineers also know how important it is to get the technical aspects right. With the Ella Hybrid they've combined elegant, almost minimalist looks with a stiffness and strength that's the foundation of a safe bike that handles intuitively. Built around the strong, hydroformed down tube, the CUBE design team has made it as easy as possible to step in and out of the Ella. The integrated luggage carrier doesn't just complement the frame's looks, it's also very stiff and a fantastically practical and secure way of carrying your belongings. We even routed the cables inside the frame, which makes gear shifting smoother and helps keep things neat and tidy.



# ELLA CRUISE HYBRID

blue 'n' blue



# ELLA CRUISE HYBRID

yellow 'n' white



The Ella Cruise Hybrid is defined by the distinctive, fresh design language of both frame and components. Elegant and understated, it's a modern classic that you'll be proud to be seen on. But don't judge it just by its looks, because this urban Bosch e-bike also boasts the kind of attention to detail that you'd expect from a far more high-end machine. The high-quality and innovative frame features easy handling, the reassurance of having passed our rigorous in-house safety tests, and a built-in luggage rack that's perfect for effortlessly carrying your everyday belongings. Bosch's benchmark drive technology is matched to Shimano's reliable and easy-to-use 7-speed hub gear, for hassle-free power to get you around town and further afield. And a host of reliable components – from the powerful hydraulic rim brakes to the comfortable suspension fork and beautifully thought out, colour-matched finishing details – are all designed to make your cycling both safe and fun. Add it all up and the conclusion is obvious: the Ella Cruise Hybrid is a class act.

- ★ **332611** Cube Ella Cruise Hybrid 500 yellow 'n' white 2020
- 332610** Cube Ella Cruise Hybrid 400 yellow 'n' white 2020
- 332601** Cube Ella Cruise Hybrid 500 blue 'n' blue 2020
- 332600** Cube Ella Cruise Hybrid 400 blue 'n' blue 2020

**FRAME** Aluminium Superlite, Comfort Ride Geometry, Premium Comfort And Safety, Integrated Carrier 2.0, Double Butted  
**SIZE** Easy Entry: 42, 46, 50, 54  
**FORK** SR Suntour NEX-E25, 50mm

**DRIVE UNIT** Bosch Drive Unit Active Plus Generation 3 (50Nm) Cruise (250Watt)  
**BATTERY** Bosch PowerPack 500  
**DISPLAY** Bosch Purion  
**CHARGER** Bosch 2A

**HEADSET** SA No.10, Semi-Integrated  
**STEM** CUBE Comfort City Stem, 31.8mm  
**HANDLEBAR** CUBE Comfort Shape Bar  
**GRIPS** CUBE Retro  
**SHIFTERS** Shimano Nexus SL-C3000-7, Revoshift  
**BRAKE SYSTEM** Magura HS11, Hydr. Caliper Brake  
**CRANKSET** SA Metropolis Comfort, 40T, 165mm  
**SPROCKET** Shimano Nexus, 20T  
**CHAIN** MC Z610, EcoProTeQ  
**CHAIN GUARD** CUBE Closed Chain Protection  
**RIMS** CUBE SX24, 36H, V-Brake  
**FRONT HUB** Shimano HB-T3000, QR  
**REAR HUB** Shimano Nexus SG-C3001-7R, 7-Speed, Nut  
**TYRES** Schwalbe Little Big Ben, Active, 40-622  
**PEDALS** CUBE PP MTB  
**SADDLE** CUBE Retro  
**SEAT POST** CUBE Performance Post, 27.2mm  
**SEATCLAMP** CUBE Screwlock, 31.8mm  
**FRONT LIGHT** Trelock Bike-i Retro Ebike, 12V, DC  
**REAR LIGHT** Herrmans H-Trace  
**KICKSTAND** CUBEstand Cmpt  
**MUDGUARDS** KS Chrom Shiny  
**BELL** CUBE Classic  
**CARRIER** CUBE Integrated Carrier 2.0, CUBE Adapter Compatible, SnapIt Compatible and Rail

**SPARE PARTS**  
**10324** CUBE Headset Orbit Z

**WEIGHT** 4,9 kg

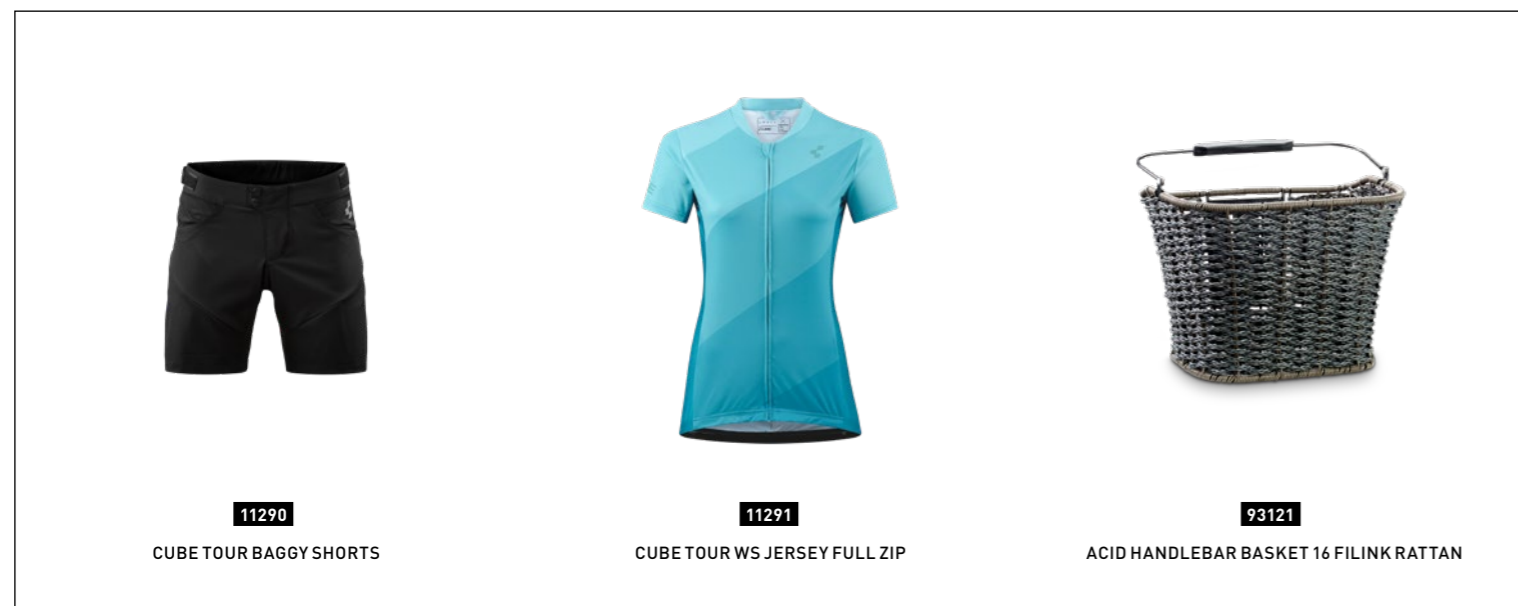

**11290**  
CUBE TOUR BAGGY SHORTS

**11291**  
CUBE TOUR WS JERSEY FULL ZIP

**93121**  
ACID HANDLEBAR BASKET 16 FILINK RATTAN

# ELLA RIDE HYBRID

green 'n' white



# ELLA RIDE HYBRID

red 'n' white

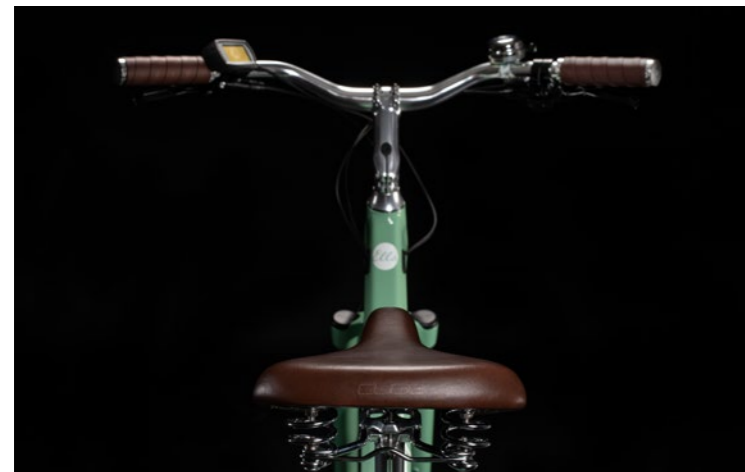

Our cute Ella Ride Hybrid blends environmentally friendly e-mobility with a refreshingly stylish take on bicycle design that you'll love: a Bosch e-bike for the fashionista in you. But it's not just about looks, because every aspect of the Ella is designed for safer, easier handling. The Easy Entry frame offers a comfortable ride position and an elegant step-through design that's perfect for everyday use. With a strong integrated luggage carrier and the reassurance of CUBE's impeccable safety and quality standards, it's a versatile companion that will slot seamlessly into your busy life. Wide-ranging Shimano 9-speed gears combine with the Bosch motor to make light work of any journey, and there are powerful hydraulic disc brakes to bring you safely to a halt, whatever the weather. A comfortable suspension fork takes the sting out of rough city streets, and details like mudguards, lights and kickstand mean we've taken care of all the essentials, so you can just enjoy the ride. Guaranteed to put a smile on your face, whatever colour you opt for...

- ★ **332511** Cube Ella Ride Hybrid 500 red 'n' white 2020
- 332510** Cube Ella Ride Hybrid 400 red 'n' white 2020
- 332501** Cube Ella Ride Hybrid 500 green 'n' white 2020
- 332500** Cube Ella Ride Hybrid 400 green 'n' white 2020

**FRAME** Aluminium Superlite, Comfort Ride Geometry, Premium Comfort And Safety, Integrated Carrier 2.0, Double Butted  
**SIZE** Easy Entry: 42, 46, 50, 54  
**FORK** Suntour NEX-E25, 50mm

**DRIVE UNIT** Bosch Drive Unit Active Plus Generation 3 (50Nm) Cruise (250Watt)  
**BATTERY** Bosch PowerPack 500  
**DISPLAY** Bosch Purion  
**CHARGER** Bosch 2A

**HEADSET** SA No.10, Semi-Integrated  
**STEM** CUBE Comfort City Stem, 31.8mm  
**HANDLEBAR** CUBE Comfort Shape Bar  
**GRIPS** CUBE Retro  
**REAR DERAILLEUR** Shimano RD-M4000-DSGS, 9-Speed  
**SHIFTERS** Shimano SL-M2010-9R, Rapidfire-Plus  
**BRAKE SYSTEM** Shimano BR-MT200, Hydr. Disc Brake (180/160)  
**CRANKSET** SA Metropolis Comfort, 38T, 165mm  
**CASSETTE** Shimano CS-HG200, 11-34T  
**CHAIN** MC X9  
**CHAIN GUARD** Herrmans Halo-38  
**RIMS** CUBE SX24, Disc, 36H  
**FRONT HUB** Shimano HB-M4050, QR, Centerlock  
**REAR HUB** Shimano FH-M4050, QR, Centerlock  
**TYRES** Schwalbe Little Big Ben, Active, 40-622  
**PEDALS** CUBE PP MTB  
**SADDLE** CUBE Retro  
**SEAT POST** CUBE Performance Post, 27.2mm  
**SEATCLAMP** CUBE Screwlock, 31.8mm  
**FRONT LIGHT** relock Bike-i Retro Ebike, 12V, DC  
**REAR LIGHT** Herrmans H-Trace  
**KICKSTAND** CUBEstand Cmp  
**MUDGUARDS** KS Chrom Shiny  
**BELL** CUBE Classic  
**CARRIER** CUBE Integrated Carrier 2.0, CUBE Adapter Compatible, SnapIt Compatible and Rail

**SPARE PARTS**  
**10149** CUBE Hanger #149 long version  
**10338** CUBE Headset Orbit 1.5E ZS 1 1/8 / 1.5 semi + 1 1/8 crown race

**WEIGHT** #4,3 kg

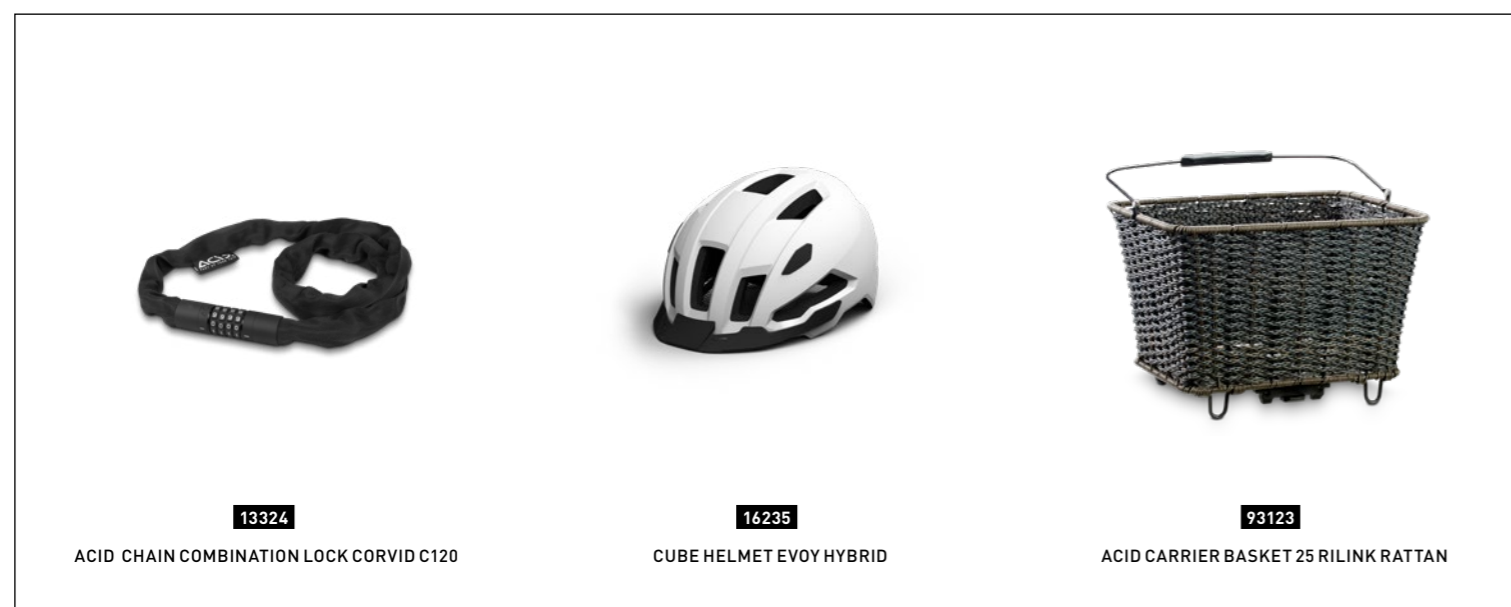

**13324**  
ACID CHAIN COMBINATION LOCK CORVID C120

**16235**  
CUBE HELMET EVOY HYBRID

**93123**  
ACID CARRIER BASKET 25 RILINK RATTAN



# KIDS



YOUNGSTER

YOUNGSTER

ROOKIE

ROOKIE



272 **ACID 240** YOUTH



278 **REACTION** YOUTH



**ACID 240 YOUTH**

The power to keep up. The Acid 240 Hybrid is the key to unlocking longer, more adventurous rides with your kids. With its Bosch drive unit and great handling, your junior rider now has the zip they need to give the grown-ups a run for their money. Best watch your back...

**REACTION YOUTH**

Harness your youngster's enthusiasm with the all new Reaction Hybrid. Borrowing technology from its grownup stablemates, this is a bike that doesn't cut corners. From the fourth generation Bosch drive system to the stunning design and components, it's a real mountain bike hybrid in miniature.

---

## FOR us #Pioneers

---

We're not going to bore you with all the details, but let's just say that fitting the Bosch drive system and battery into a mountain bike frame suitable for kids isn't as straightforward as our engineers have made it look. Long experience of working with this superb drive system has given them the knowhow to build an exceptionally neat aluminium frame around it, putting the drive unit in precisely the right position for the best handling and semi-integrating the battery into the down tube for a sleek, elegant look. There's a tough 30.9mm seat post, internal cable routing to keep gear shifting clean and precise without the need for fiddly maintenance, and we even included mounts to fit a CUBE kickstand. All that's left to do is for your junior rider to jump on, and show the adults how it's done.



# ACID 240 HYBRID YOUTH SL

black 'n' blue



We all know that kids aren't daft. They see what mum and dad are riding, and there'll come a time when they'll want something just as good. Well, now they can. The new Acid 240 Hybrid Youth SL features the same Bosch drive unit and battery as many of our adult bikes, so it'll give your young rider the power boost they need to ride further, faster and longer – good news for family rides. Better yet, we've chosen some great components that give many of our full-size bikes a run for their money. For example, the Shimano Deore 10-speed transmission features an enormous gear range and slick, reliable shifting. Combined with the Bosch system's smooth, quiet power delivery, it gives your youngster all the oomph they need to tackle any climb – and keep up with mum and dad. The Suntour XCR air fork is easily adjustable to suit smaller, lighter riders, and does a great job of ironing out the lumps in the trail. And powerful Shimano hydraulic disc brakes with a 180mm rotor at the front ensure there's plenty of stopping power for safely reining in any excess enthusiasm. It's all your little ripper needs to extend their riding horizons as their confidence and abilities grow.

★ **330060** Cube Acid 240 Hybrid Youth SL 400 black 'n' blue 2020

**FRAME** Aluminium Superlite, Gravity Casting, Agile Ride Geometry, Double Butted, Disc Only, Internal Cable Routing  
**SIZE** #4"  
**FORK** #R Suntour XCR LO Air JR, 80mm

**DRIVE UNIT** #B Bosch Drive Unit Active Generation 3 (40Nm) Cruise (250Watt) Youth Edition (20km/h)  
**BATTERY** #B Bosch PowerPack 400  
**DISPLAY** #B Bosch Purion  
**CHARGER** #B Bosch 2A

**HEADSET** #SA No.10, Semi-Integrated  
**STEM** #CUBE Performance Stem Pro, 31.8mm  
**HANDLEBAR** #DG Slater JR, 660mm  
**GRIPS** #DG Slater JR  
**REAR DERAILLEUR** #S Shimano Deore RD-M6000-GS, 10-Speed  
**SHIFTERS** #S Shimano Deore SL-M6000, Rapidfire-Plus  
**BRAKE SYSTEM** #S Shimano BR-MT200, Hydr. Disc Brake (180/160)  
**CRANKSET** #SA Metropolis, 38T, 152mm  
**CASSETTE** #S Shimano Deore CS-HG500, 11-42T  
**CHAIN** #MC X10  
**RIMS** #CUBE ZX20, 32H, Disc, Tubeless Ready  
**FRONT HUB** #S Shimano Deore HB-M6000, QR, Centerlock  
**REAR HUB** #S Shimano Deore FH-M6000, QR, Centerlock  
**TYRES** #S Schwalbe Smart Sam, Kevlar, 2.35  
**PEDALS** #CUBE PP MTB  
**SADDLE** #DG 18 Fly JR  
**SEAT POST** #CUBE Performance Post, 30.9mm  
**SEATCLAMP** #CUBE Varioclose, 34.9mm

**WEIGHT** #8,9 kg

**SPARE PARTS**  
**10148** CUBE Hanger #148 short version  
**10324** CUBE Headset Orbit Z



**10768**  
JUNIOR JERSEYS/S



**10991**  
JUNIOR BAGGY SHORTS



**16258**  
HELMET ANT



Why should adults get to have all the fun? The Acid 240 Hybrid Youth brings the power and versatility of our renowned e-bike range within reach of the youngsters in your family, giving them an extra power boost so they can tackle longer rides and keep up with the grown-ups. Making use of the same technologies and design features as our full-size e-MTBs, it features a Bosch Active drive unit with Purion controller, and a 400Wh battery for long-lasting power. We won't bore you with all the details, but let's just say that fitting the Bosch drive system into a mountain bike frame suitable for kids wasn't as straightforward as our engineers have made it look. It's all designed with safe handling and our usual emphasis on durability in mind, so your kids can enjoy the ride and you can too, knowing that we've taken care of all the details. The Suntour XCT JR fork is designed specifically with younger, lighter riders in mind and helps smooth out the trail ahead, while Shimano's easy-shifting 9-speed transmission has the range your junior rider needs to make light work of any climb. Put the spark back in your family rides, and get your child an Acid 240 Hybrid Youth...

★ **330050** Cube Acid 240 Hybrid Youth 400 actionteam 2020

**FRAME** Aluminium Superlite, Gravity Casting, Agile Ride Geometry, Double Butted, Disc Only, Internal Cable Routing  
**SIZE** #4"  
**FORK** #R Suntour XCT JR, 80mm

**DRIVE UNIT** #B Bosch Drive Unit Active Generation 3 (40Nm) Cruise (250Watt) Youth Edition (20km/h)  
**BATTERY** #B Bosch PowerPack 400  
**DISPLAY** #B Bosch Purion  
**CHARGER** #B Bosch 2A

**HEADSET** #SA No.10, Semi-Integrated  
**STEM** #CUBE Performance Stem Pro, 31.8mm  
**HANDLEBAR** #CUBE Rise Trail Bar, 680mm  
**GRIPS** #CUBE Performance Grip  
**REAR DERAILLEUR** #S Shimano RD-M3000-SGS, 9-Speed  
**SHIFTERS** #S Shimano SL-M2010-9R, Rapidfire-Plus  
**BRAKE SYSTEM** #S Shimano BR-MT200, Hydr. Disc Brake (180/160)  
**CRANKSET** #SA Metropolis, 38T, 152mm  
**CASSETTE** #S Shimano CS-HG201, 11-36T  
**CHAIN** #MC X9  
**RIMS** #CUBE ZX20, 32H, Disc, Tubeless Ready  
**FRONT HUB** #S Shimano HB-TX505, QR, Centerlock  
**REAR HUB** #S Shimano FH-TX505, QR, Centerlock  
**TYRES** #Schwalbe Smart Sam, Active, 2.35  
**PEDALS** #CUBE PP MTB  
**SADDLE** #DG 18 Fly JR  
**SEAT POST** #CUBE Performance Post, 30.9mm  
**SEATCLAMP** #CUBE Varioclose, 34.9mm

**WEIGHT** #9,2 kg

**SPARE PARTS#**  
**10148** CUBE Hanger #148 short version  
**10324** CUBE Headset Orbit Z

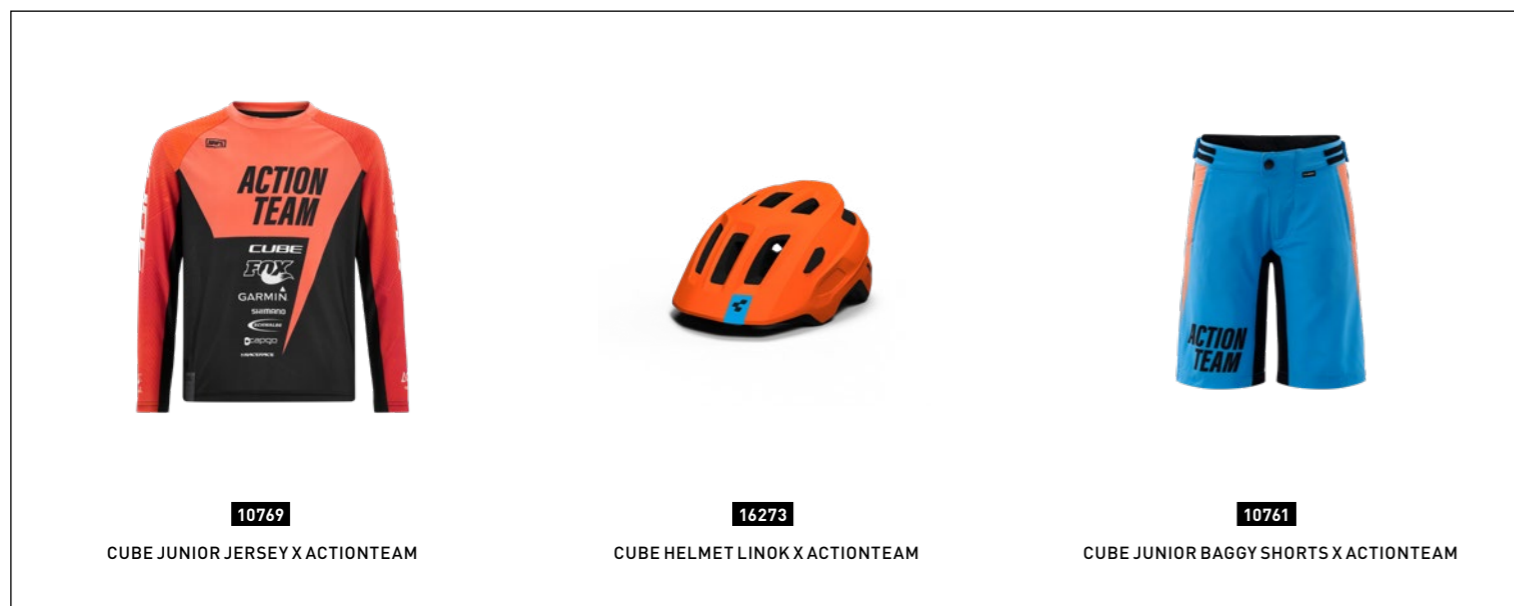

**10769**  
CUBE JUNIOR JERSEY X ACTIONTEAM

**16273**  
CUBE HELMET LINOK X ACTIONTEAM

**10761**  
CUBE JUNIOR BAGGY SHORTS X ACTIONTEAM

---

## FOR us #Pioneers

---

Why shouldn't youthful enthusiasm be rewarded? That was our starting point for the Reaction Hybrid Youth, which uses the same technologies and frame construction techniques as our adult Reaction Hybrid frames. The oversized dimensions of the gravity cast down tube – along with the 1.5in head tube – help create a stiff backbone for a bike that, let's be honest, is going to be ridden with enthusiasm and quite likely a healthy disregard for risk. This is also home for the Bosch battery, whilst the smooth and powerful drive unit sits in its own housing under a cover that's accessed by a single screw. Internally routed cables keep gears shifting smoothly with minimal maintenance and, should your young ripper find themselves riding even more challenging lines, an upgrade to a stealth dropper post is quick and easy. Feed their enthusiasm – and see the positive reaction.



# REACTION HYBRID YOUTH

blue'n'orange



Building a perfectly proportioned, balanced e-MTB that handles brilliantly and fits smaller riders really well isn't easy, but our engineers love a challenge. The brand-new Reaction Hybrid Youth has all the features of our new adult Reaction Hybrid frames, in a 13.5in size that's ideal for the super-keen junior riders in your family. Powered by Bosch's superb fourth-generation CX drive unit, its 400Wh battery lives neatly inside the down tube and can be charged in situ, if needed. The 1.5in head tube, big cross-section down tube and oversized chain stays provide an efficient platform for the Bosch system to boost your young rider's power output, channelled through Shimano's smooth-shifting and incredibly reliable 10-speed Deore transmission to the 2.35in rear tyre. We selected powerful Shimano hydraulic disc brakes with a large 180mm front rotor, for dependable stopping power in all weathers. There's a kickstand mount for an easy upgrade, and it's even possible to fit a remote dropper post if you find you have an aspiring World Champ on your hands. And the Suntour XCM fork ensures that, however keen they get, there's plenty of help on tap to keep the rubber side down and the wheels rolling. Because enthusiasm should be rewarded, but safety's important too. The Reaction Hybrid Youth 400 has got it all covered, so you can get even more out of your family riding time...

★ **330070** Cube Reaction Hybrid Youth 400 blue'n'orange 2020

**FRAME** Aluminium Superlite, Gravity Casting, Agile Ride Geometry, 1.5 Headtube, Internal Cable Routing, Semi-Integrated Battery  
**SIZE** #3.5"  
**FORKS** R Suntour XCM Coil, 100mm

**DRIVE UNIT** Bosch Drive Unit Performance CX Generation 4 (75Nm) Cruise (250Watt)  
**BATTERY** Bosch PowerPack 400  
**DISPLAY** Bosch Purion  
**CHARGER** Bosch 2A

**HEADSET** #SA Orbit Z 1.5B ZS-R, Top Zero-Stack 1 1/2" (OD 56mm), Bottom Zero-Stack 1 1/2" (56mm)  
**STEM** #CUBE Performance Stem Pro, 31.8mm  
**HANDLEBAR** #CUBE Rise Trail Bar, 680mm  
**GRIPS** #CUBE Performance Grip  
**REAR DERAILLEUR** #Shimano Deore RD-M6000-DGS, 10-Speed  
**SHIFTERS** #Shimano Deore SL-M6000, Rapidfire-Plus  
**BRAKE SYSTEMS** #Shimano BR-MT200, Hydr. Disc Brake (180/160)  
**CRANKSET** #CID E-Crank, 38T, 160mm  
**CASSETTE** #Shimano Deore CS-HG500, 11-42T  
**CHAIN** #MC X10  
**RIMS** #CUBE EX23, 32H, Disc, Tubeless Ready  
**FRONT HUB** #Shimano HB-TX505, QR, Centerlock  
**REAR HUB** #Shimano FH-TX505, QR, Centerlock  
**TYRES** #Schwalbe Smart Sam, K-Guard, 2.35  
**PEDALS** #CUBE PP MTB  
**SADDLE** #Natural Fit Venec Lite  
**SEAT POST** #CUBE Performance Post, 30.9mm  
**SEATCLAMP** #CUBE Varioclose, 34.9mm

**WEIGHT** #0,9 kg

**SPARE PARTS**  
**8000** CUBE Headset Orbit Z 1.5E ZS  
**10149** CUBE Hanger #149 long version



**16184**  
CUBE HELMET ANT X ACTIONTEAM



**11975**  
CUBE GLOVES JUNIOR PERFORMANCE X ACTIONTEAM



**10780**  
CUBE JUNIOR JERSEY

# GEO METRY

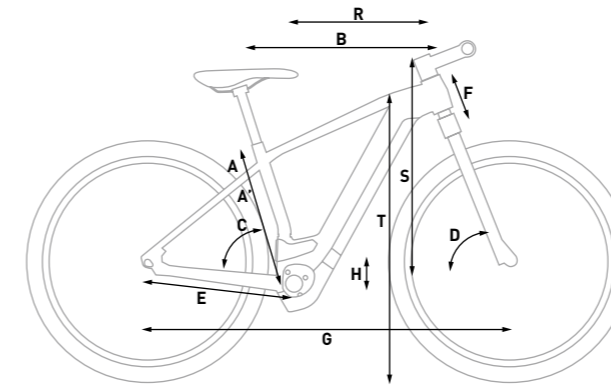

■ ELITE HYBRID C.62 RACE / SL

	A	A'	B	C	D	E	F	G	H	R	S	T
17"	405	359	585	74	68	460	105	1146	-65	405	635	776
19"	450	401	605	74	68	460	110	1166	-65	424	639	802
21"	495	440	625	74	68	460	120	1187	-65	441	649	826
23"	545	486	645	74	68	460	136	1209	-65	456	663	861

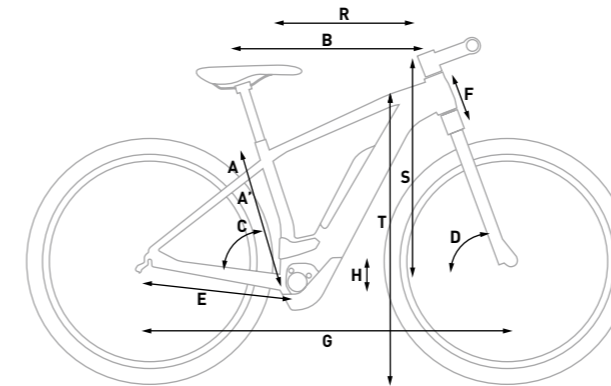

■ REACTION HYBRID ONE / PRO / PRO ALLROAD / RACE

	A	A'	B	C	D	E	F	G	H	R	S	T
13.5"	355	306	545	74	68	441	110	1085	-46,5	379	591	717
15"	370	323	560	74	68	441	120	1103	-46,5	393	600	728
17"	405	355	580	74	69	460	110	1129	-65	402	628	765
19"	450	400	600	74	69	460	120	1149	-65	420	638	798
21"	495	460	620	74	69	460	131	1170	-65	437	648	832
23"	545	490	640	74	69	460	146	1191	-65	452	662	870

TRAPEZE

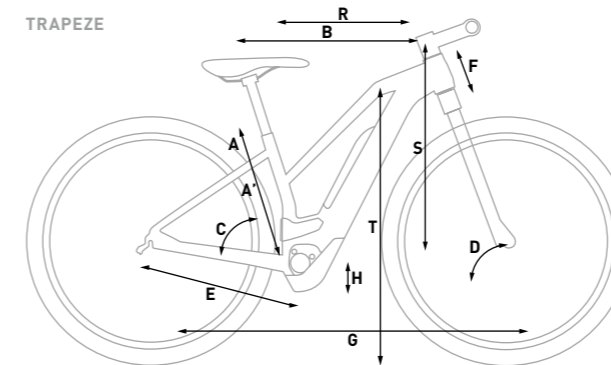

■ REACTION HYBRID PRO / PRO ALLROAD

	A	A'	B	C	D	E	F	G	H	R	S	T
Z 15"	370	252	560	74	68	441	120	1103	-46,5	393	600	694
Z 17"	405	248	580	74	69	460	110	1129	-65	403	628	710
Z 19"	450	272	600	74	69	460	120	1149	-65	419	638	715

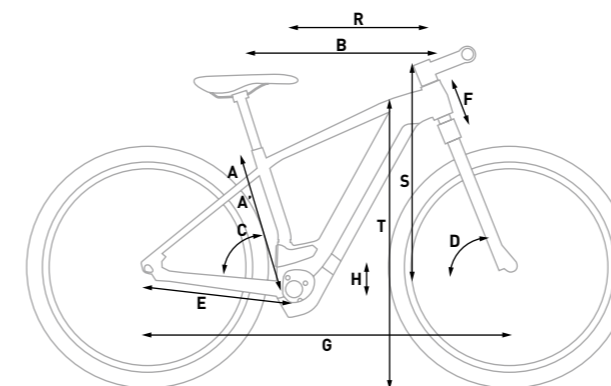

■ REACTION HYBRID EX / EX ALLROAD / EXC / SL / SLT

	A	A'	B	C	D	E	F	G	H	R	S	T
15"	375	325	580	74	67,5	460	100	1146	-65	403	628	750
17"	405	354	585	74	68	460	105	1146	-65	405	635	775
19"	450	400	605	74	68	460	110	1166	-65	424	639	800
21"	495	426	625	74	68	460	120	1187	-65	441	649	832
23"	545	470	645	74	68	460	136	1209	-65	456	663	870

LEGEND

A SEAT TUBE MM	E CHAIN STAYS MM	R REACH MM
A' SEAT TUBE CENTER-CENTER MM	F HEAD TUBE MM	S STACK MM
B TOP TUBE HORIZONTAL MM	G WHEELBASE MM	T STANDOVER HEIGHT - 80MM FROM THE BB MM
C SEAT TUBE DEGREE	H BB-HEIGHT TO HUB MM	
D HEAD TUBE ANGLE DEGREE	I REAR TRAVEL MM	

TRAPEZE

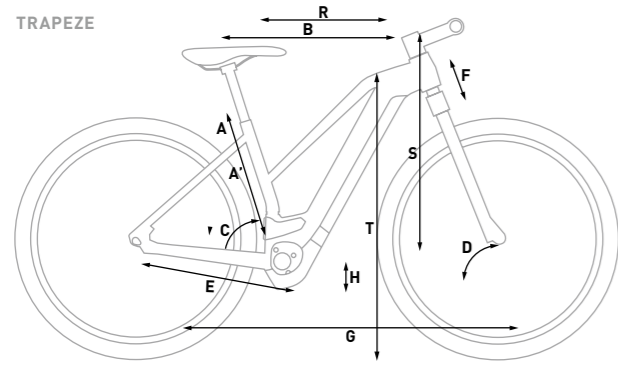

■ REACTION HYBRID EX / EX ALLROAD / EXC / SL

	A	A'	B	C	D	E	F	G	H	R	S	T
Z15"	375	232	580	74	67,5	460	100	1146	-65	403	628	700
Z17"	405	243	585	74	68	460	105	1146	-65	405	635	702
Z19"	450	251	605	74	68	460	110	1166	-65	424	639	707

■ ACID HYBRID

	A	A'	B	C	D	E	F	G	H	R	S	T
15"	370	317	560	74,5	68	474	105	1136	-65	391	610	731
17"	405	353	575	73,5	69	474	112	1129	-65	391	622	760
19"	450	401	595	73,5	69	474	123	1150	-65	408	632	793
21"	495	445	615	73,5	69	474	133	1170	-65	425	641	823
23"	545	498	635	73,5	69	474	148	1192	-65	441	655	860

TRAPEZE

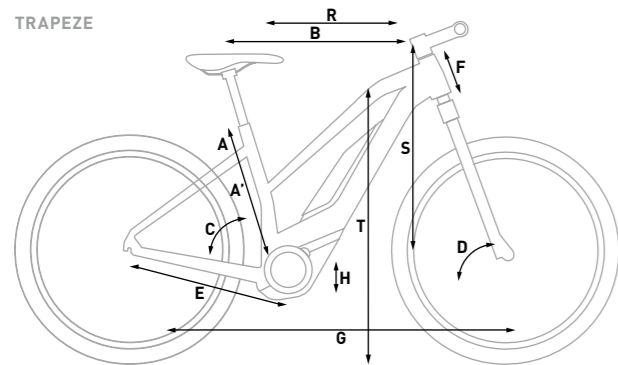

■ ACID HYBRID

	A	A'	B	C	D	E	F	G	H	R	S	T
Z15"	370	246	560	74,5	68	474	105	1136	-65	391	610	701
Z17"	405	222	575	73,5	69	474	112	1129	-65	391	622	688
Z19"	450	243	595	73,5	69	474	123	1150	-65	408	632	702

■ STEREO HYBRID 160 HPC

	A	B	C	D	E	F	G	H	I	R	S	T
16"	375	568	75,5	65	441,5	105	1183	-12,5	160	420	598	772
18"	420	590	75,5	65	441,5	112	1206	-12,5	160	440	605	772
20"	470	613	75,5	65	441,5	122	1230	-12,5	160	460	614	772
22"	520	638	75,5	65	441,5	142	1259	-12,5	160	480	632	799

■ STEREO HYBRID 140 HPC RACE / SL / SLT

	A	B	C	D	E	F	G	H	I	R	S	T
16"	375	569	75,2	66	457	105	1185	-36	140	416	614	771
18"	420	590	75,2	66	457	108	1206	-36	140	436	616	771
20"	470	614	75,2	66	457	118	1231	-36	140	457	626	771
22"	520	641	75,2	66	457	138	1258	-36	140	476	644	806

■ STEREO HYBRID 140 HPC TM / ACTIONTEAM

	A	B	C	D	E	F	G	H	R	S	T
16"	375	571	74,8	65,6	457	105	1189	-32,6	411	617	777
18"	420	592	74,8	65,6	457	108	1210	-32,6	431	620	777
20"	470	616	74,8	65,6	457	118	1235	-32,6	452	629	777
22"	520	642	74,8	65,6	457	138	1262	-32,6	471	647	813

■ STEREO HYBRID 120

	A	B	C	D	E	F	G	H	I	R	S	T
16"	390	582	75,3	67	490	117	1214	-37,5	120	426	613	779
18"	420	590	75,3	67	490	127	1223	-37,5	120	431	622	781
20"	465	611	75,3	67	490	137	1245	-37,5	120	449	632	783
22"	515	636	75,3	67	490	152	1272	-37,5	120	470	645	821

■ AGREE HYBRID C:62 / NUROAD HYBRID C:62

	A	A'	B	C	D	E	F	G	H	R	S	T
53CM	490	483	537	74,5	71,5	430	137	1016	-74	382	560	750
56CM	520	514	560	73,5	72,5	430	167	1020	-74	385	593	780
59CM	550	544	583	72,5	72,5	430	197	1031	-74	387	621	810

LEGEND

A SEAT TUBE MM	E CHAIN STAYS MM	R REACH MM
A' SEAT TUBE CENTER-CENTER MM	F HEAD TUBE MM	S STACK MM
B TOP TUBE HORIZONTAL MM	G WHEELBASE MM	T STANDOVER HEIGHT - 80MM FROM THE BB MM
C SEAT TUBE DEGREE	H BB-HEIGHT TO HUB MM	
D HEAD TUBE ANGLE DEGREE	I REAR TRAVEL MM	



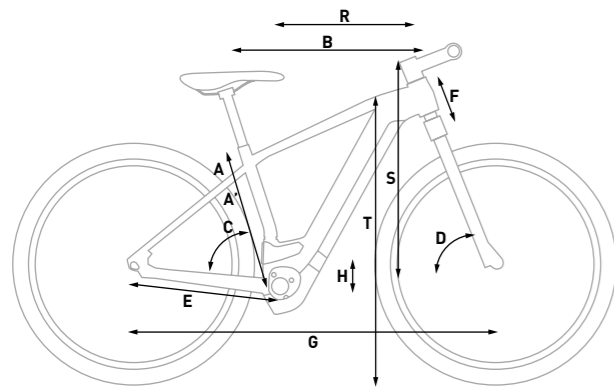

■ ACCESS HYBRID EX / EX ALLROAD / EXC / SL / SLT

	A	A'	B	C	D	E	F	G	H	R	S	T
15"	375	325	580	74	67,5	460	100	1146	-65	403	628	750
17"	405	354	585	74	68	460	105	1146	-65	405	635	775
19"	450	400	605	74	68	460	110	1166	-65	424	639	800

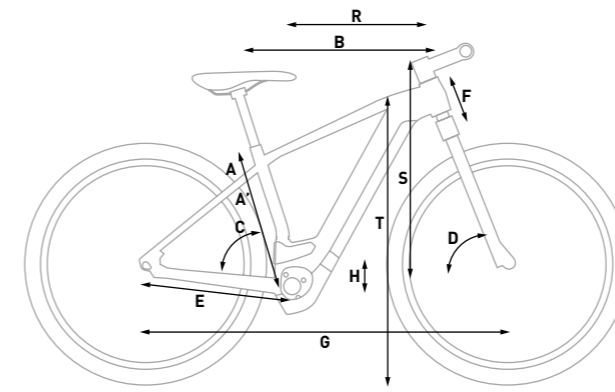

■ CROSS HYBRID PRO ALLROAD / RACE ALLROAD / SL ALLROAD

	A	A'	B	C	D	E	F	G	H	R	S	T
50CM	480	435	590	74	68,5	460	110	1144	-67,5	415	624	808
54CM	520	473	600	74	68,5	460	114	1155	-67,5	423	632	835
58CM	560	513	610	74	68,5	460	133	1165	-67,5	427	650	866
62CM	600	553	620	74	68,5	460	154	1177	-67,5	430	669	899

TRAPEZE

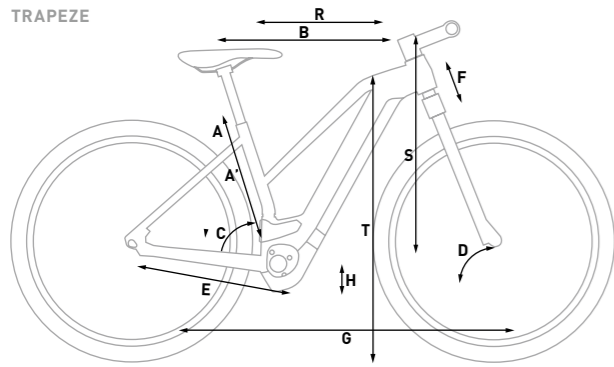

■ ACCESS HYBRID EX / EX ALLROAD / EXC / SL /

	A	A'	B	C	D	E	F	G	H	R	S	T
Z15"	375	232	580	74	67,5	460	100	1146	-65	403	628	700
Z17"	405	243	585	74	68	460	105	1146	-65	405	635	702
Z19"	450	251	605	74	68	460	110	1166	-65	424	639	707

TRAPEZE

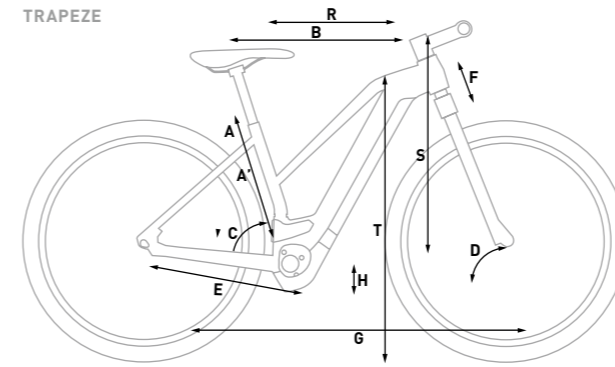

■ CROSS HYBRID PRO ALLROAD / RACE ALLROAD / SL ALLROAD

	A	A'	B	C	D	E	F	G	H	R	S	T
Z 46CM	440	289	580	74,5	68,5	460	114	1140	-67,5	408	632	725
Z 50CM	480	292	590	74	68,5	460	125	1145	-67,5	409	642	732
Z 54CM	520	303	600	74	68,5	460	134	1156	-67,5	416	651	744

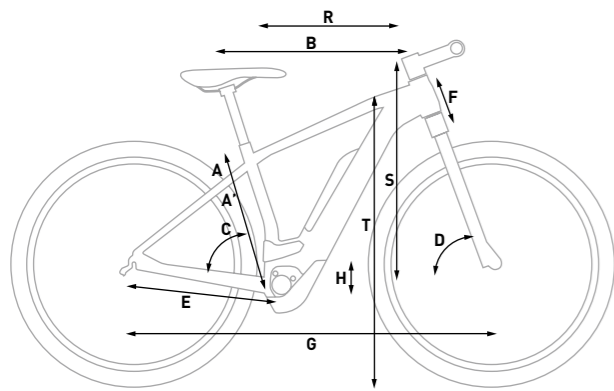

■ ACCESS HYBRID / ONE / PRO / PRO ALLROAD / RACE

	A	A'	B	C	D	E	F	G	H	R	S	T
13.5"	355	306	545	74	68	441	110	1085	-46,5	379	591	717
15"	370	323	560	74	68	441	120	1103	-46,5	393	600	728
17"	405	355	580	74	69	460	110	1129	-65	402	628	765
19"	450	400	600	74	69	460	120	1149	-65	420	638	798

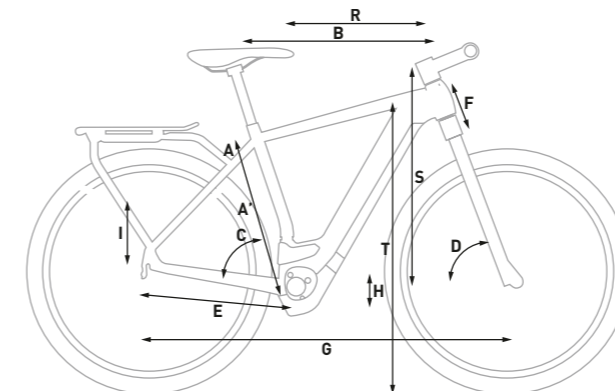

■ KATHMANDU HYBRID ONE / PRO / EXC / SL / SLT / 45

	A	A'	B	C	D	E	F	G	H	R	S	T
50CM	480	435	590	74	68,5	460	105	1144	-67,5	415	624	808
54CM	520	473	600	74	68,5	460	114	1155	-67,5	423	632	835
58CM	560	513	610	74	68,5	460	133	1165	-67,5	427	650	866
62CM	600	553	620	74	68,5	460	154	1177	-67,5	430	669	899

TRAPEZE

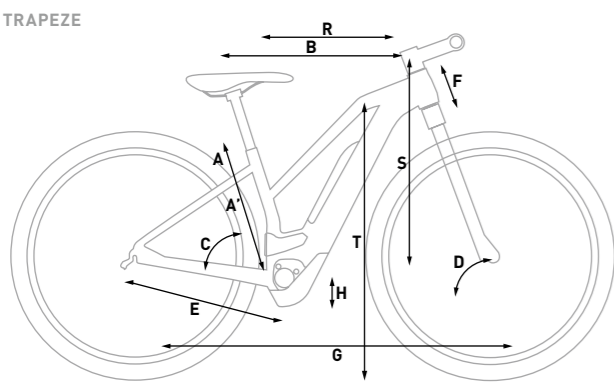

■ ACCESS HYBRID PRO / PRO ALLROAD

	A	A'	B	C	D	E	F	G	H	R	S	T
Z17"	405	248	580	74	69	460	110	1129	-65	403	628	710
Z19"	450	272	600	74	69	460	120	1149	-65	419	638	715

TRAPEZE

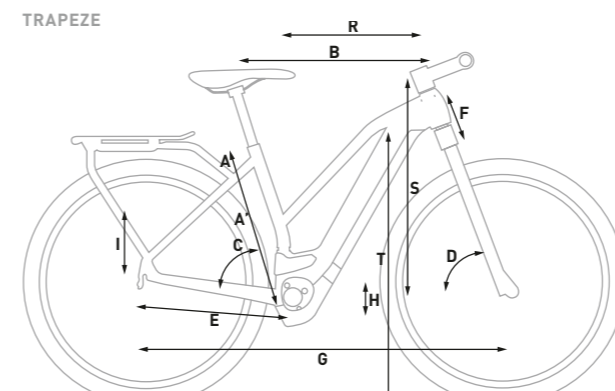

■ KATHMANDU HYBRID ONE / PRO / EXC / SL / SLT / 45

	A	A'	B	C	D	E	F	G	H	R	S	T
Z 46CM	440	289	580	74,5	68,5	460	114	1140	-67,5	408	632	725
Z 50CM	480	292	590	74	68,5	460	125	1145	-67,5	409	642	732
Z 54CM	520	303	600	74	68,5	460	134	1156	-67,5	416	651	744

LEGEND

- A SEAT TUBE MM
- A' SEAT TUBE CENTER-CENTER MM
- B TOP TUBE HORIZONTAL MM
- C SEAT TUBE DEGREE
- D HEAD TUBE ANGLE DEGREE
- E CHAIN STAYS MM
- F HEAD TUBE MM
- G WHEELBASE MM
- H BB-HEIGHT TO HUB MM
- I REAR TRAVEL MM
- R REACH MM
- S STACK MM
- T STANDOVER HEIGHT - 80MM FROM THE BB MM

EASY ENTRY

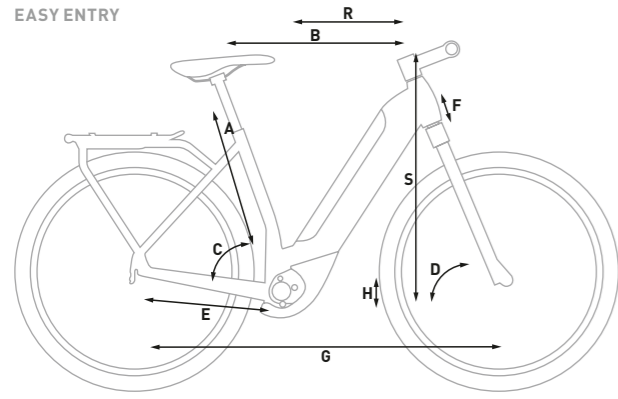

■ KATHMANDU HYBRID ONE / PRO / EXC / SL / SLT

	A	B	C	D	E	F	G	H	R	S	T
EE 46CM	440	590	73,5	68,5	460	145	1141	-65,5	397	659	525
EE 50CM	480	600	73,5	68,5	460	145	1151	-65	407	658	522
EE 54CM	520	610	73,5	68,5	460	150	1162	-65	416	663	516
EE 58CM	560	620	73,5	68,5	460	155	1172	-65	424	668	514

EASY ENTRY

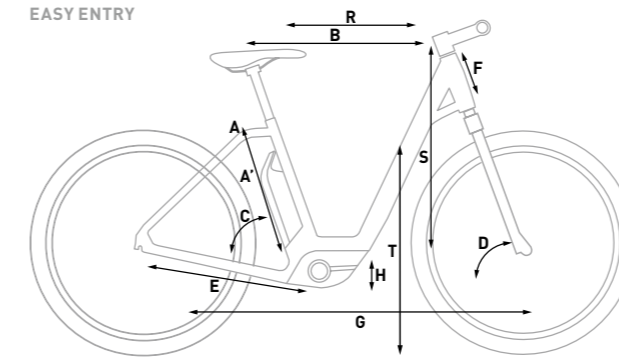

■ TOWN HYBRID ONE / PRO / PRO RT / EXC / EXC RT / SL / TOWN SPORT HYBRID ONE / PRO / EXC

	A	B	C	D	E	F	G	H	R	S	T
EE 42CM	420	581	72	69	540	160	1173	-70	377	632	391
EE 46CM	465	593	72	70	540	165	1174	-70	386	641	391
EE 50CM	480	605	72	70	540	175	1186	-70	395	651	391
EE 54CM	520	617	72	70	540	190	1198	-70	402	665	391
EE 58CM	560	629	72	70	540	210	1210	-70	407	683	391

■ NATURE HYBRID ONE ALLROAD / EXC ALLROAD / TOURING HYBRID ONE / PRO / EXC

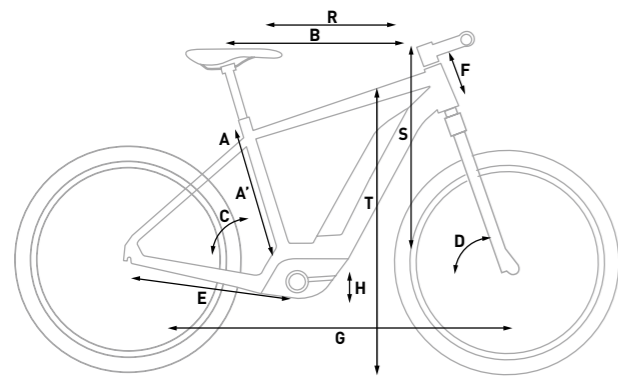

	A	A'	B	C	D	E	F	G	H	R	S	T
50CM	480	429	582	73	69,5	470	130	1112	-60	396	608	791
54CM	520	463	593	73	70	470	150	1118	-60	401	629	821
58CM	560	503	604	73	70	470	170	1130	-60	406	647	853
62CM	600	542	615	73	70	470	190	1143	-60	411	666	884

EASY ENTRY

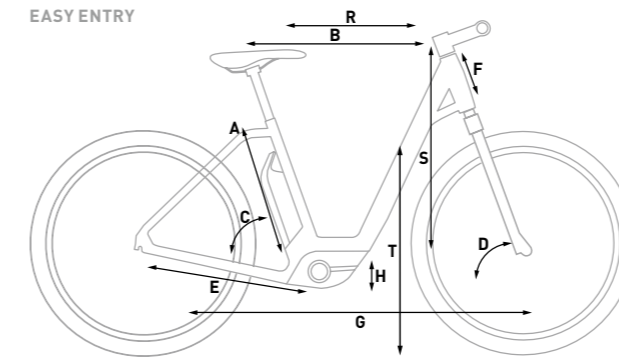

■ ELLA RIDE HYBRID / ELLA CRUISE HYBRID

	A	B	C	D	E	F	G	H	R	S	T
EE 42CM	420	581	72	69	540	160	1173	-70	377	632	391
EE 46CM	465	593	72	70	540	165	1174	-70	386	641	391
EE 50CM	480	605	72	70	540	175	1186	-70	395	651	391
EE 54CM	520	617	72	70	540	190	1198	-70	402	665	391

TRAPEZE

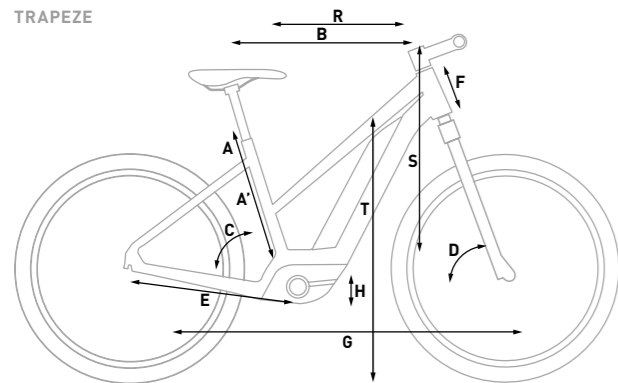

■ NATURE HYBRID ONE ALLROAD / EXC ALLROAD / TOURING HYBRID ONE / PRO / EXC

	A	A'	B	C	D	E	F	G	H	R	S	T
Z 46CM	440	219	571	73	69	470	140	1107	-60	383	615	653
Z 50CM	480	240	582	73	70	470	150	1107	-60	390	629	672
Z 54CM	520	218	593	73	70	470	165	1119	-60	397	643	658

EASY ENTRY

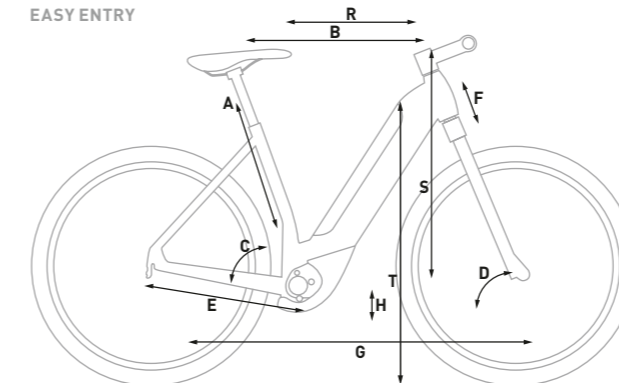

■ NURIDE HYBRID PRO / EXC / SL ALLROAD / PRO ALLROAD / EXC ALLROAD

	A	B	C	D	E	F	G	H	R	S	T
EE 46CM	440	590	73,5	68,5	460	145	1141	-65,5	397	659	525
EE 50CM	480	600	73,5	68,5	460	145	1151	-65	407	658	522
EE 54CM	520	610	73,5	68,5	460	150	1162	-65	416	663	516
EE 58CM	560	620	73,5	68,5	460	155	1172	-65	424	668	514

EASY ENTRY

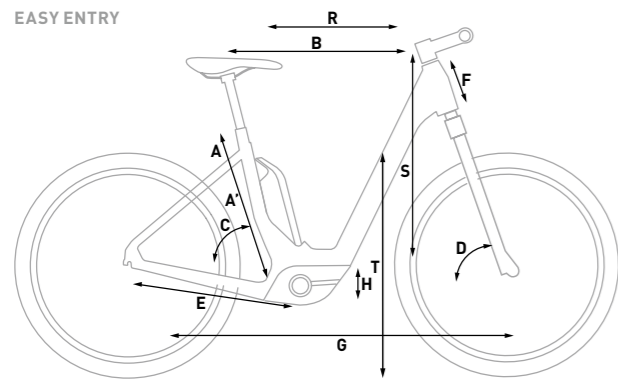

■ TOURING HYBRID ONE / PRO / EXC

	A	B	C	D	E	F	G	H	R	S	T
EE 46CM	450	571	73	69,5	480	140	1107	-70	380	627	396
EE 50CM	480	582	73	70	480	150	1115	-70	388	639	396
EE 54CM	520	593	73	70	480	165	1125	-70	396	653	396
EE 58CM	560	604	73	70	480	195	1137	-70	401	681	396

EASY ENTRY

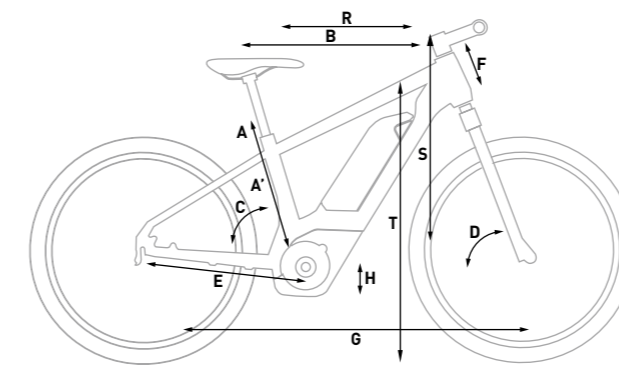

■ ACID 240 HYBRID YOUTH / SL YOUTH

	A	A'	B	C	D	E	F	G	H	R	S	T
24"	350	300	512	73	68	416	130	1006	-40	349	537	693

LEGEND

- A SEAT TUBE MM
- A' SEAT TUBE CENTER-CENTER MM
- B TOP TUBE HORIZONTAL MM
- C SEAT TUBE DEGREE
- D HEAD TUBE ANGLE DEGREE
- E CHAIN STAYS MM
- F HEAD TUBE MM
- G WHEELBASE MM
- H BB-HEIGHT TO HUB MM
- I REAR TRAVEL MM
- R REACH MM
- S STACK MM
- T STANDOVER HEIGHT - 80MM FROM THE BB MM

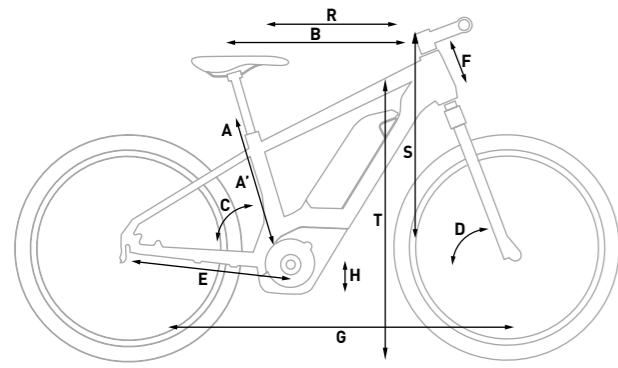

■ REACTION HYBRID YOUTH

	A	A'	B	C	D	E	F	G	H	R	S	T
13.5"	355	306	545	72,3	68	441	110	1085	-46,5	379	591	716

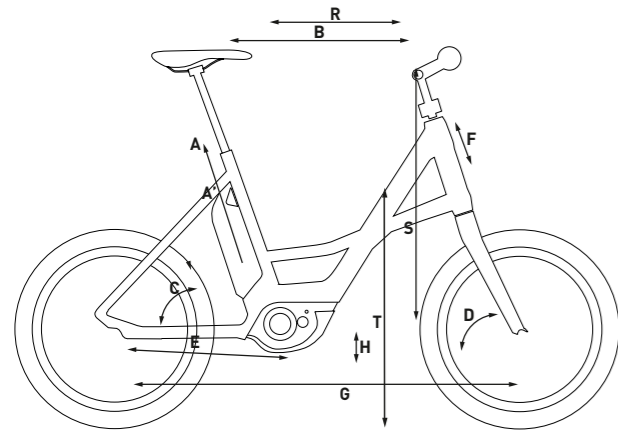

■ COMPACT

	A	A'	B	C	D	E	F	G	H	R	S	T
20	480	426	556	72	72	445	260	1079	21	407	545	495

LEGEND

A SEAT TUBE MM	E CHAIN STAYS MM	R REACH MM
A' SEAT TUBE CENTER-CENTER MM	F HEAD TUBE MM	S STACK MM
B TOP TUBE HORIZONTAL MM	G WHEELSBASE MM	T STANDOVER HEIGHT - 80MM FROM THE BB MM
C SEAT TUBE DEGREE	H BB-HEIGHT TO HUB MM	
D HEAD TUBE ANGLE DEGREE	I REAR TRAVEL MM	

**CUBE BIKES**  
Ludwig-Hüttner-Straße 5-7  
95679 Waldershof  
Germany

**www.cube.eu**

**E-Mail:** info@cube.eu

#### **CLAUSE RESERVING ERRORS**

\* All indicated weights are for the pictured bike (middle frame size) without pedals. Deviations are possible.

All images and product descriptions listed are correct at time of press. Despite careful preparation and checking of all data we reserve the right to make changes without notice. Errors cannot be excluded.

#### **RIGHTS OF USE**

The rights for all used text, pictures, graphic designs and logos are owned by the company PENDING SYSTEM GmbH & Co. KG. Use is only permitted with the permission of PENDING SYSTEM GmbH & Co. KG. This approval is subject to revocation.



DESIGN &  
DATABASE  
PUBLISHING  
POWERED BY



4c media

